

Development of An Intelligent Grating CAD System----GRTCAD

Ma YongSheng

Gintic Institute of Manufacturing Technology, 71 Nanyang Drive, Singapore 638075

and

Gao HuiXing

SOE Dept., Ngee Ann Polytechnic, 535 Clementi Road, Singapore 599489

Abstract. This paper reports a CAD product developed for grating design. In this system, methods for designing different types of grating panels are modelled using an object oriented approach. Design rules can be defined interactively by using friendly dialogue boxes. Advanced generic 2D dividing algorithms with the consideration of grating area boundaries, openings, gap size, supporting structure and panel properties are coded. Drawing geometry, layout and bill of material are generated automatically. Industrial feedback has indicated improvement on design quality and productivity. **Key words:** CAD, Grating.

1. Terminology

Grating panel: A completed piece of grating, cut to size banded and notched as per cutting drawing.

Bearing bars: Load carrying bars of uniform section in rolled steel spanning between supporting steel members. It is also known as *Loading Bars*.

Crossing bars: Rods of uniform section in square twisted steel, electro-forged at right angle to the bearing bars.

Length of panel (L): The overall measurement of a panel when measured parallel with the bearing bars.

Width of panel (W): The overall measurement of a panel when measured parallel with the crossing bars.

Bearing bar pitch: The standard distance between two neighbouring bearing bars.

Crossing bar pitch: The standard distance between two neighbouring crossing bars.

Openings: The spaces cut out in grating areas to accommodate some obstacles, such as pipes, columns, tanks, etc.

Nominal circle: A circle defined by the user and used for circular platform to measure panel material size. Particularly, the panel width is measured along this circle.

Standard width: The width of a standard panel (W). For polar bearing bar direction, this parameter is measured along the circumference of the nominal circle.

Minimum width: The minimum size of a separated panel in the width direction. Similarly, for polar bearing bar direction, this parameter is measured along the circumference of the nominal circle.

Gross area of panel: The total area of flooring including openings, notches, etc; as used in material estimation (Area = L x W).

Net area of panel: The real geometrical area of a panel excluding openings, notches, etc, as used in weight calculation and certain accurate quotation.

Bill Of Material (BOM): A list of grating panels with series number, group number, gross length and width, gross or net area, cutting drawing number, etc. This document is used in production planning and invoicing.

Cutting list: A set of production assignment documents with cutting drawings for all grating panels, planned time schedule, and other technical requirements.

Packing list: Document contains information for a set of panel groups for delivery purpose. Panels are grouped according to panel size, total weight of each group, and other delivery instructions.

Start cutting point: A point indicating the distance between the first crossing bar in a panel and the parallel panel cutting edge measured along the bearing bar direction.

2. Introduction

Grating is necessary in shipbuilding, refinery construction, steel plant construction, etc. In this process, a platform with different layouts is covered by a set of panels so that the platform can be used for servicing or loading purpose. However, so far, there is no any specific CAD system for grating design. Grating design requires experienced engineers to calculate panel layout from structural layout.

Grating design includes selecting grating category according to the load range, and calculating gratings layout for a given area, which is constrained by the supporting structure and obstacles according to certain distributing patterns. Grating layout drawings are then produced. The total gross grating area is calculated so that quotation for estimating and invoicing can be obtained. Each panel's geometry is later used to produce the panel cutting drawing. This cutting drawing is used to cut the panel shape from standard grating panel. The net area of each panel is used to calculate the weight. This is used for planning and shipment packing. Throughout the process, the Bill Of Material (BOM) is required.

Grating areas can mainly have rectangular or circular shapes. Certain openings are necessary in order to accommodate pipe lines or any other obstacle. Loading bar alignment among panels is important in order to achieve consistent appearance. Because the panel material comes with standard width and length,

dividing methods should be optimised to reduce material waste. Traditionally, the grating design and material estimation were done manually.

3. System description

The system is essentially a specially developed, automatic design and drawing generation system for the grating engineering industry. PC and AutoCAD were selected as the hardware platform and the basic graphic tool respectively. This CAD system can automatically produce design drawings for a grating area with a given supporting structure. The profiles of the supporting structures and the openings for obstacles consist of straight lines and circular arcs. After users click in the drawing contours of the outer support structure, openings, and inner supports in the grating area, grating layout drawings are automatically generated with the consideration of the technical rules for dividing the grating area into panels. Rules are selected by the user. It can also calculate the grating area, BOM, start cutting point, cutting list, packing list while panels are created. All operations are menu-driven. After the system generates and displays the drawing of panels, users can still modify these panels interactively.

3.1 Specifications

- The system can deal with an area with inner support lines, even when they have cross openings.
- Standard panel width is used whenever possible.
- Gap generation is automatic for a fixed gap value and floating gap values optimised in a range.
- If the panel width is smaller than the minimum width specified, the small panel is then merged with its neighbouring panel.
- Panels can be modified easily.
- Text in panel labelling and other automatically generated documents, such as bill of material, cutting points, can be modified easily.

3.2 Data Structure and Repository

For creating the relationship between a geometrical block and a panel data structure, a special user defined object type is used. Each grating piece is drawn as an AutoCAD block which has many attributes, such as a unique name and a grouping number. A separate data file is created when panels are generated. All panel information including segment definition, position and block name are written to this file. During an interactive operation process, such as modifying the position of a panel grouping number, when a panel is clicked, the system can return the panel's name. Thus, a relationship between the panel and the data file is established. If there is any modification on any panel, its data records are updated accordingly. The panels with the same dimensions, in the same project, can be assigned with the same cutting number if the user selects this option. The user can take a batch or several batches to process the layout in a design session.

4. Panel Generation Algorithm and General Rules

Two types of grating areas are considered, i.e., rectangular and circular platforms. Three panel distribution patterns are designed according to the bearing bar direction, i.e., horizontal, vertical, and polar patterns. Many intelligent judgements can be performed, such as standardising the width of the panels, selecting the suitable dividing line within an internal opening, setting the gap between panels, and labelling panels automatically. Certain technical requirements, such as maximum and minimum grating panel dimensions are observed.

4.1 Standard Panel Width and Sub-Standard Width

In order to minimise material waste, it should be appreciated that generated panels should have standard widths whenever possible. In Fig.1, the grating area is a simple rectangle. The bearing bar direction is vertical, so the panels created are in a row. In Fig.1(a), the gap value is set as a fixed value, 10 mm, and the standard panel width is 905mm. When dividing the grating area from right to left, the first eight identical panels are created with the standard width 905mm, while the last one has a width of 740mm.

For grating panel cutting, it is always preferred to cut next to a bearing bar so that the side edge of the panel is neat with a solid bar. Therefore, if the standard panel width cannot be achieved, a width that can accommodate certain number of bearing bars is preferred. There could be many width values that satisfy this condition. These values are referred as sub-standard panel widths. Sub-standard widths are calculated by this formula: $Bearing_bar_pitch \times (No.\ of\ bearing\ bars - 1) + Bearing_bar_width$.

In the examples shown in this paper, the bearing bar thickness is 5mm and the pitch is 30mm. If the minimum and the maximum numbers of bearing bars are 4 and 45 respectively, the sub-standard values are the integer series from 95mm to 1325mm with an increment of 30mm.

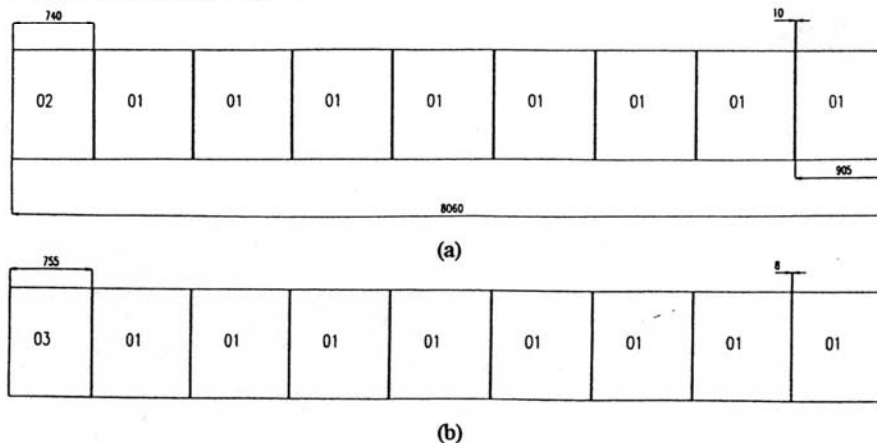

Fig.1 Simple rectangular platforms

To achieve the sub-standard, the gap value has to be adjustable. In Fig.1(b), the gap value is adjusted to 8mm. The width of the last panel becomes 755mm which is one of the sub-standard widths. When the user selected either horizontal or vertical loading bar direction, the rules in this section are applied.

When the user activates the "Auto-adjust gap" option, panel gaps will be dynamically adjusted in a range, between the minimum and the maximum values allowable, to ensure that the panel widths are equal to the standard width or sub-standard widths. Otherwise, gap values will be kept constant throughout the panel generation process.

4.2 Rules to Deal with Openings

Most of the openings are either circles or rectangles. There must be a dividing line passing through each opening. Otherwise, grating panels have to be installed from the top of the obstacle, and doing this is often not possible.

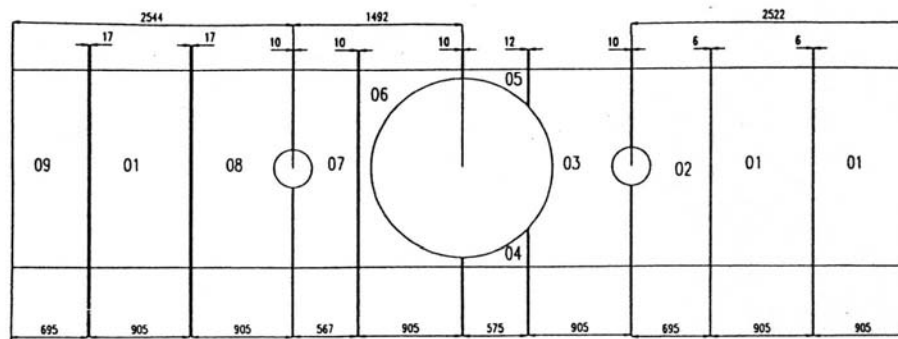

Fig.2 Grating area with circular openings

For a circular opening, the dividing line must go through its centre point. An example is shown in Fig.2. There are three circular openings. With the gap value varying from 6mm to 17mm, the panels created have either standard or sub-standard widths.

However, when the opening is not a circle, e.g. a rectangle, the dividing line can be at any position within the range in which the opening has the maximum height. This range is defined as the limit zone of the opening.

For example, when using the vertical bearing bar direction, opening (1) in Fig.3 can be divided at any horizontal position between A and B, while opening (2) can be between P and Q. Again, in order to generate panels with widths either equal to the standard width or sub-standard widths, dividing line positions are optimised with great effort. In this system, the limits of each opening in the horizontal and

vertical (or in radial and angular for polar pattern) directions and their corresponding zones in which the opening reaches limits are calculated.

It should be noted that if the bearing bar direction is vertical, dividing lines to generate panels are also vertical. Then, the dividing line through an opening must fall in the common horizontal range of the corresponding zones for its upper and lower limits. Similarly, limits zones can be found if the bearing bar direction is horizontal. If the bearing bar direction is polar, dividing lines are in radial directions, the dividing line through an opening, must fall in the common range of the corresponding angular zones for the outer and inner limits related to the reference centre of the platform.

GRTCAD provides an option for the user to decide whether the dividing line positions can be away from the centre of their limit zones. This is controlled by the "Dividing at square centre" toggle button.

In Fig.3, all panels' widths are adjusted by changing the neighbouring gap values which vary from 10 to 14. Note that opening (1) and opening (2) are overlapping, and there is some overlapping limit zone. The system automatically identifies this type of overlapping and decides a dividing position within the common limit zone, hence positively avoids small panels being generated. It should also be noted that the first dividing line from right to left results in two panels on the right side, i.e., panel "01" and "02". Similar rules are applicable to a polar pattern although the restrictions for a polar pattern is much more stringent because the dividing line must be in the radial direction in order to have reasonable load distribution.

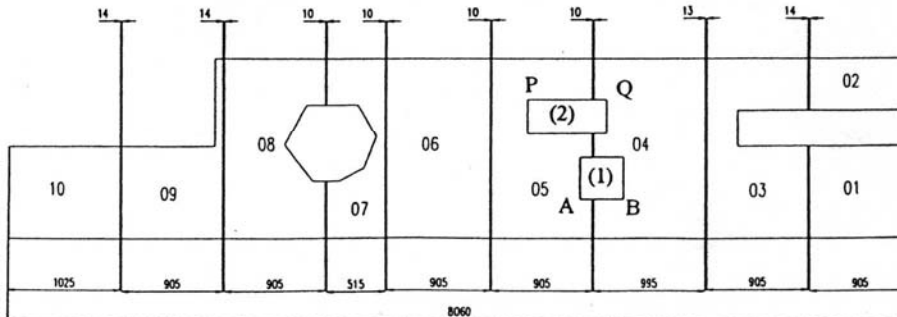

Fig.3 Rectangular grating area with irregular openings

4.3 Panel Group Numbering

The user can group identical panels into a group so that the machining of these panels can be carried out without repeating set-up processes. This system mainly identify those panels with simple shapes, such as rectangles and typical fan shapes. This is done automatically when the user toggle the "Group Numbering" switch on. Otherwise, the

panel number is assigned in the sequence of their generation. The user is also allowed to insert, modify, or confirm the starting panel number for the current platform before starting to generate panels. For some special cases, where an opening is small rectangle, if gaps can be adjusted, the opening is divided at one end so that the panel manufacturer only needs to cut the opening on one side panel.

4.4 Rules to Deal with Inner Support Lines

Quite often, the grating area spans in a large space, inner support structure are therefore necessary to support grating panels to achieve satisfactory rigidity. The support structure design is out of the scope of this system. However they are considered as inner support lines in grating panel generation. For rectangular platforms, supporting lines are perpendicular to the bearing bar direction, while for polar platforms, the support lines are in radial directions.

In GRTCAD, the grating area is divided into sub-areas considering the gaps along the supporting lines, and the panels in each sub-area are then generated in order automatically. In Fig.4, it can be observed that there are two inner support lines in the horizontal direction (the bearing bar direction is vertical). Note the lower support line crosses the big opening and the system has created grating panels properly.

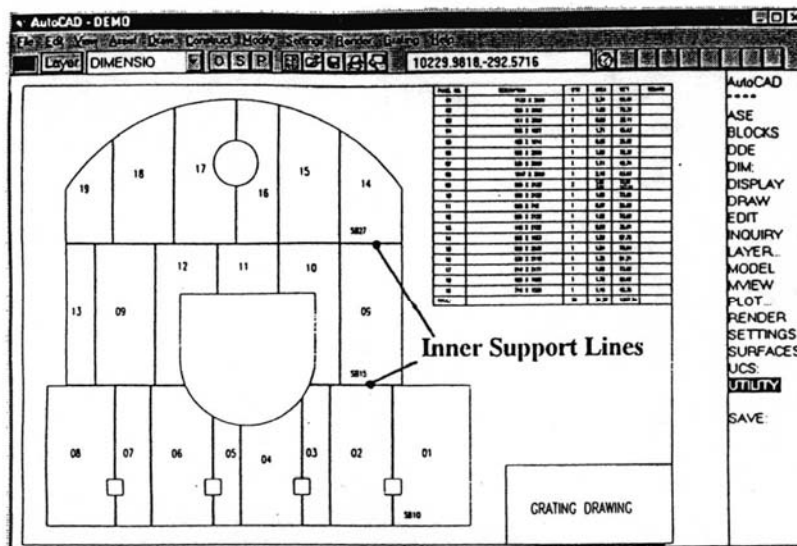

Fig.4 Grating area with inner support lines

4.5 Avoiding Small Panels

Panels generated cannot be too small because small panels are inconvenient to cut and install. In GRTCAD, in order to avoid small panels, the next generated panel size is predicted. If the panel width is smaller than the minimum width, the next small panel will not be generated. Instead, the current panel will include this

small area. Hence, the current panel becomes bigger. For polar bearing bar direction, this minimum allowable width is measured along the circumference of the nominal circle, which is also used to measure the standard width in the dividing process.

5. Editing Capability

GRTCAD provides many user-friendly interactive modification tools, such as changing the shape and name of a panel, dividing one panel into two or merging two into one, etc. When panels are created or modified under the normal AutoCAD environment, they can be re-integrated into the grating database by running a "read-in" program. These modification functions make this system more flexible to meet customers' requirements and to cope with complicated geometry. A dialogue box showing panel modification options is shown in Fig.5.

6. User Interfaces

A customised menu group under "Grating" is inserted into AutoCAD's top menu bar. If the user clicks the grating command item, the GRTCAD is activated, and the first menu for selecting operations is then displayed. After clicking a grating operation button, a few AutoCAD-like dialogue boxes will be displayed for selecting operation options, and inputting data. For example, GRTCAD displays a dialogue box to allow the user to set initial parameters for panel generation. These parameters include:

- Bearing bar direction, the choice can be either Horizontal, or Vertical, or Polar.
- Standard panel width, minimum width, bearing bar pitch, thickness, and height; crossing bar pitch, starting panel number, etc.
- Dividing principles applied, such as whether the gap value can be floated, and the range for auto-adjustment; whether the dividing line for a rectangular opening must be at the centre or it can be adjusted; and whether panels are grouped with one panel number if they are identical, etc.

These dialogue boxes are defined by using AutoCAD Dialogue Control Language (DCL). A map with important menus is shown in Fig.5. Used items in dialogue boxes include *Radio buttons*, *Editing boxes*, and *Toggle switches*. The user's settings for each dialogue box are backed up in a data file and reloaded when the system is started. By doing so, the user will save a lot of time for inputting these values. This data file is updated instantly when the settings are modified. Hence, the system can "learn" from the user.

7. System Output

Grating drawings are the most important output. Fig.4 shows an example for a rectangular platform. In Fig.6, a polar platform is shown. All panels can be output individually to create cutting drawings. The system can automatically point out the position of cutting start point for each panel in order to align all the crossing bars of the neighbouring panels. These cutting start points are displayed on the

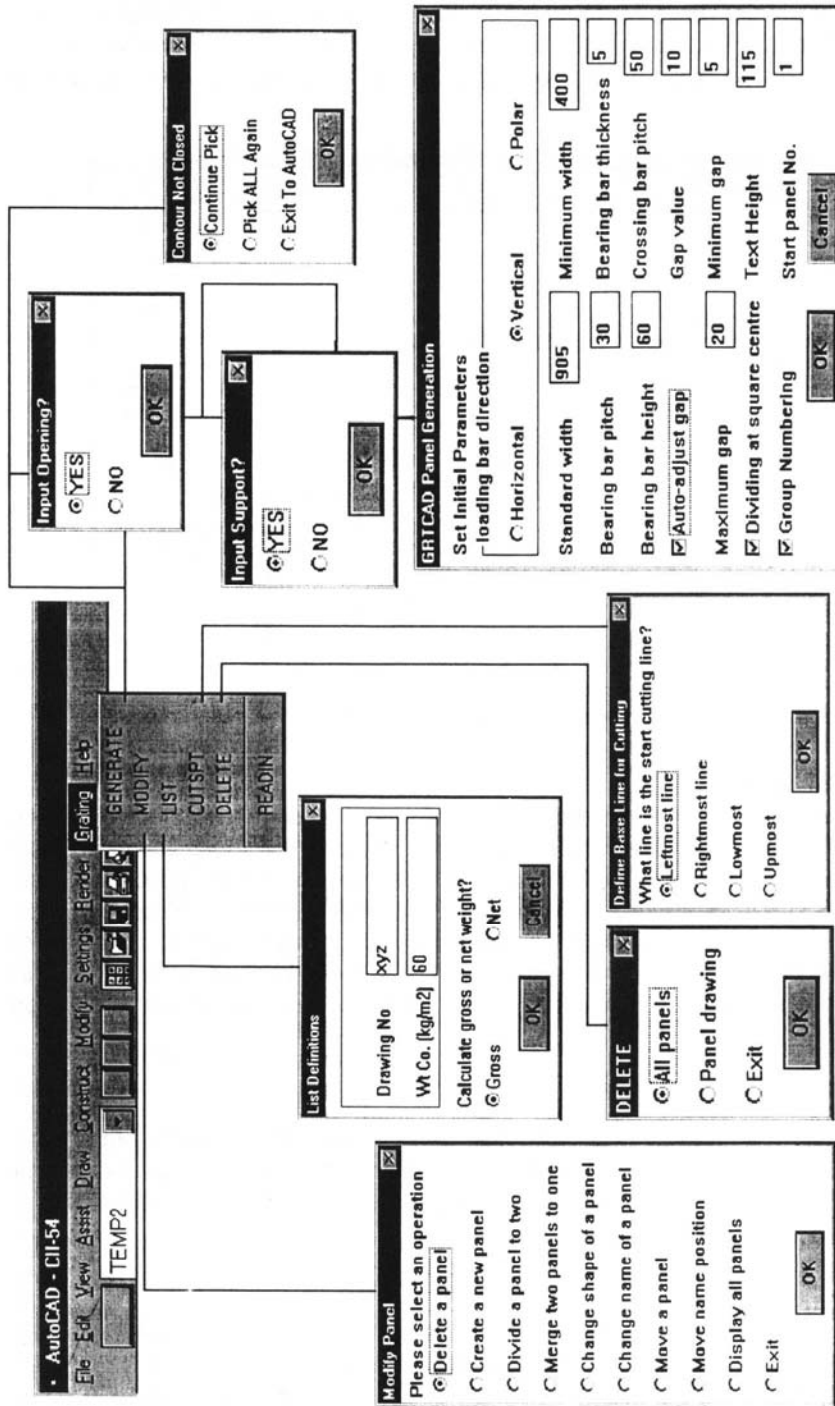

Fig.5 Menu Map in GRTCAD

manufacture drawings. All the output data documents, such as bill of material, cutting list and packing list, are generated automatically using the integrated data base. Hence, it eliminates human errors. The output data can also be exported to Lotus 1-2-3 spread sheets.

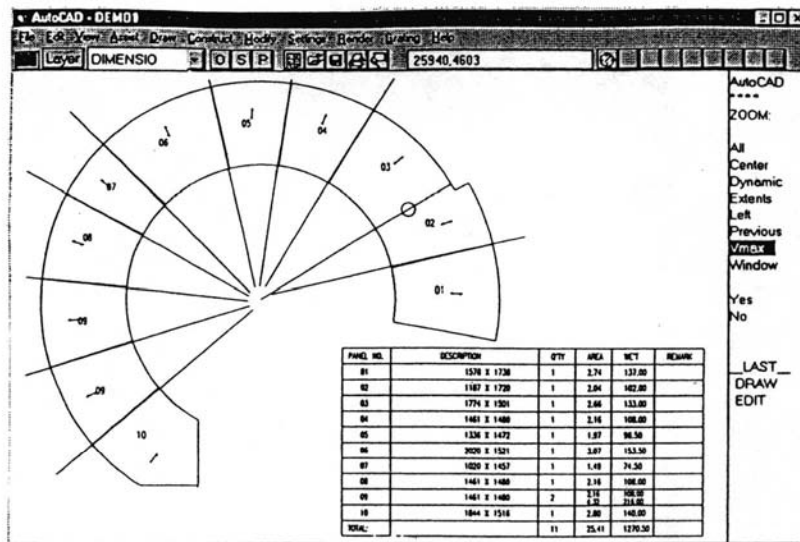

Fig.6 Circular grating area with openings

8. Conclusion

The intelligent features in this system allow the user to cut down operation and training time. The easy-to-use data entering format has shorten the learning curve. The user needs less man power to deal with grating panel design. Higher quality and more accurate grating drawings can be produced with high efficiency. Human errors are eliminated in the different output data documents. The approach used in this paper has been adopted by several other specialised CAD development projects such as generating scaffolding structures and design 3D metal form structures in construction engineering.

9. Acknowledgement

The authors would like to acknowledge Sangjin Dahe Industries Pte Ltd (S) and the EDB of Singapore government for their sponsorship, and Ngee Ann Polytechnic for permitting the relevant projects being carried out. AutoCAD[®] is a trade mark of Autodesk Inc.

References

1. Sangjin Dahe Industries Pte Ltd (S), Company Document, *Specifications for Grating Panel Cutting and Operational Documentation* (1994).
2. Y. Ma and H. Gao, *Grating CAD System --- GRTCAD User's Guide*, (1996).