

## TOOL PATHS FOR FACE MILLING CONSIDERING CUTTER TOOTH ENTRY/EXIT CONDITIONS

YONG-SHENG MA

Dept. of Mechanical Engineering, Ngee Ann Polytechnic, 535 Clementi Rd.  
Singapore 2159, Singapore  
E-mail: may@np.ac.sg

### ABSTRACT

Cutter tooth entry/exit conditions, in interrupted cutting, affect cutting performance considerably. In this work, tool path generation for face milling, using window-frame based approach, is investigated. Two objectives are pursued individually, the minimum total travel distance and keeping favourable cutter tooth entry/exit conditions during cutting.

Key words: Milling, Tool Path, CAD/CAM.

### 1. Introduction

In milling, brittle tool failure is closely related to cutter tooth entry/exit conditions due to the interrupted nature. The roles played by cutter tooth entry/exit conditions depend upon different work materials (Barrow, Ghani and Ma 1993).

*Entry problem.* When a cutter cuts into the workpiece, depending on the tool geometry and orientation of the tool and workpiece, the initial contact between the tool and the workpiece can be at a point, along a line, or over an area. Experimental results suggest (Opitz and Beckhaus 1970) that the tool life is influenced by the form of initial contact which is in turn determined by the entry angle (Fig.1) of the cutter.

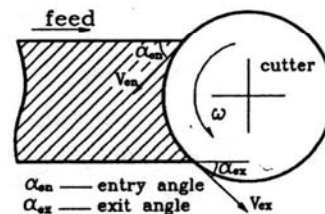

Fig.1 Entry angle and exit angle

It is recognised that the initial impact between tool and workpiece plays an essential role in tool failure when cutting very hard materials, such as chilled cast-iron and ultra high strength steels (Barrow, Ghani and Ma 1993).

*Exit problem.* The cutter tooth exit conditions are sensitive to tool failure when machining carbon and low alloy steels, stainless steels and the Co, Ni, Ti alloys etc (Barrow, Ghani and Ma 1993), because that negative shearing, or 'foot forming', occurs immediately prior to the cutter exiting the workpiece (Yellowley 1974, Pekelharing 1984). At low cutting velocities, negative shearing contributes to chip adhesion, which in turn leads to adhesive pitting on the rake face, at high velocities, it contributes to tool failure because of sudden unloading (Yellowley 1974).

The magnitude of the reversed tensile stress is determined by the effective chip thickness. Kamaruddin (Kamaruddin 1984) predicted the relationship between the negative shearing angle  $\beta$  and the exit angle  $\theta$  by applying classical mechanics (Fig.2) as:  $\beta = (\theta + \alpha - \pi/2)/2$ . This equation predicts that the greater the exit angle  $\theta$  is, the more severe 'foot

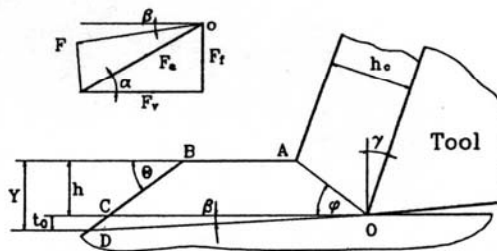

Fig.2 Geometry at exit in interrupted cutting

forming' is. Regarding the cutting geometry, the cutter tooth exit angle directly determines the effective chip thickness and whether 'foot forming' occurs.

When cutting light alloys, brasses and many forms of cast iron, negative shearing does not cause tool failure. This is because the chip adhesion at low velocities is insufficient to cause pitting on the rake face while at high velocities the compressive stress, even when reversed, is too low to cause cutting edge chipping.

**Cutting Modes.** Up-milling and down-milling are commonly encountered (Fig.3). In down-milling, the exit process is smooth, i.e. the effective chip thickness reduces gradually. In up milling the entry process is smooth. Hence, different cutting modes are preferred for different materials.

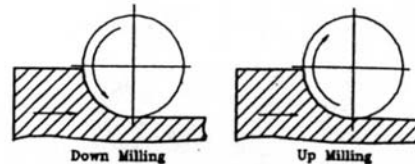

Fig.3

**Types of Tool Paths.** To generate tool paths, two approaches are normally used, i.e. staircase (or 'zigzag') milling, and window-frame based (or 'spiral') milling. However, when using zig-zag tool path, the cutting mode changes frequently. Zig milling is derived from zigzag milling by replacing the sequence of alternate movements by a sequence of cutting movements in one direction. Due to tool lifting and machine's re-positioning error, the surface finish is affected. The staircase method also involves a lot of transient cutting geometry when entering and leaving the workpiece, so the cutter tooth entry/exit conditions are neither under control nor predictable.

In the second approach (Fig.4), the surface is milled along a profile equidistant to the surface boundary, with the tool stepping inwards for the next pass. This approach is able to keep a constant width of cut and favourable entry/exit angles during most of the cutting time, and the cutter can machine surfaces without lifting the cutter as long as the cutter can access the area. However, there exists a covering problem in traditional CAM systems when the stepover is larger than the cutter radius, and the cutter tooth entry/exit angles are never considered (Ma 1994).

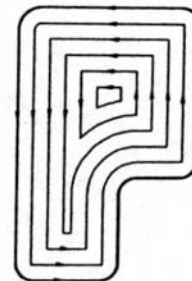

Fig.4 Spiral milling

## 2. Medial axis diagram

The concept of medial axis diagram is originated from Voronoi diagram. A simple definition of the Voronoi diagram is given in (Held 1991): "The Voronoi diagram of a set P of points in the plane is a partition of the plane such that each region of the partition represents (the sub-set of) points that are closer (under the Euclidean Metric) to one member of P than to any other member".

One extension of sets of points is to take line segments into consideration. Considering the interior of a polygon, a medial axis diagram is defined in (Lee 1982): "the medial axis diagram of a polygon is the set of Voronoi segments less the segments incident with concave vertices". An example is shown in Fig.5.

The trunk of a medial axis diagram is defined as the set of segments in the medial axis diagram excluding those segments which are linked to end points of the polygon. In Fig.5, the trunk of the medial axis diagram consists of  $M_1M_2M_3M_4M_6M_8M_9$ ,  $M_6M_7$  and  $M_4M_5$ . Those branches of bisector segments on the medial axis diagram that are linked

with end points of the polygon, and without crossing any junction point of the diagram, such as  $M_1q_4$ ,  $M_1q_5$ , and  $M_2q_6$  etc, are referred to as the end branches. Each segment in the medial axis diagram is the bisector of two elements on the polygon. The area width of a polygon  $w$  is defined as a function of a point  $P$  on the medial axis diagram ( $M$ ),  $w(P)$ , ( $P \in M$ ), it equals to the sum of the minimum distances from the given point  $P$  to its two corresponding boundary elements on the polygon. In Fig.5,  $Q_1$  is a point on the medial axis segment  $M_2M_3$ , the area width at  $Q_1$  equals to  $d_1+d_2$ , where  $d_1$  and  $d_2$  are the minimum distance from  $Q_1$  to its two corresponding segments, i.e.  $q_6q_7$  and  $q_4q_3$ .

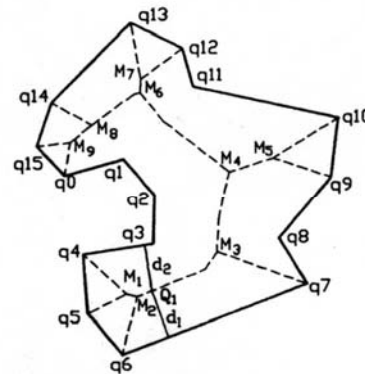

Fig.5 Medial axis diagram of a simple polygon

### 3. Problem analysis

In this work, tool path generation is started by offsetting the boundary profile. The drive profiles are first generated by offsetting the boundary profile, layer by layer, until the last offset profile can not be shrunk any more. The offset distance is the specified radial width of cut  $b$ . These drive profiles are then used to generate cutter Centre Location (CL) profiles by offsetting them by a distance  $b-R$ , where  $R$  is the cutter radius.

When the  $b/D$  ( $D$ , cutter diameter) ratio is less than 0.5, and the cutter tooth entry/exit conditions are not considered, similar to the traditional approach, the tool path generation is merely a process of offsetting. However, more often than not, a  $b/D$  ratio larger than 0.5 is preferred, and for some work/tool material combinations, the cutting performance will be improved considerably if the cutter tooth entry/exit conditions are favourable. In these cases, simple offsetting techniques are not satisfactory.

A simple L-shaped surface is shown in Fig.6. Drive profile  $DP_0$  is the boundary profile,  $DP_1$ ,  $DP_2$ ,  $DP_3$  are the inner layers of drive profiles. The work material between two drive profiles is supposed to be machined by one cutting pass. Please note that narrow part of the area enclosed by  $DP_2$  where the area width ( $w$ ) is less than  $2b$ , and the area, enclosed by  $DP_3$ , need special treatment.

Assuming  $b/D$  ratio is greater than 0.5, all the cases where  $0 < w \leq 2b$ , can be classified into three geometry patterns, i.e. when  $2b \geq w > 2R$ ,  $2(b-R) < w \leq 2R$ , and  $0 \leq w \leq 2(b-R)$ .

*Pattern 1: When  $2b \geq w > 2R$ .* Since  $w \leq 2b$ , if the cutter follows the U shaped CL profile (Fig.7), then the area can be fully covered by the going (first) and the returning passes. However, the actual radial widths for the first cutting pass and the returning cutting pass are different. For the first pass, since  $w > 2R$ , i.e.  $w > b$ , the radial width is always  $b$  (Fig.7(b)). Therefore the cutter tooth exit angle is

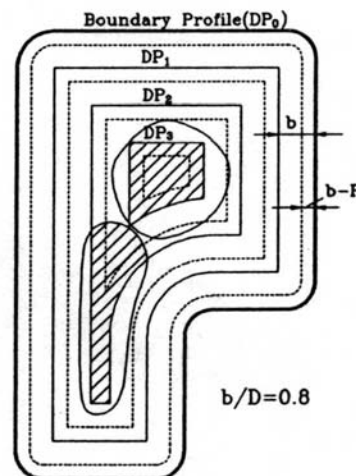

Fig.6 Narrow areas enclosed by drive profiles

kept favourable ( $0^\circ$ ). The returning pass clears the material left behind by the first pass. The actual radial width of cut equals  $w-b$ , and  $b \geq w-b > 2R-b$ . Its value changes according to the component geometry, i.e. the value of  $w$ . This means that the exit angle for the returning pass may change considerably. Suppose  $w_2$  is the distance from the cutter centre to the exit edge (Fig.7(c)), then  $w_2 = w_1 - R$ . Since  $2R \geq w_1 > 2(2R-b)$ ,  $R \geq w_2 > 3R-2b$ . If  $b/D=0.75$ , then  $R \geq w_2 > 0$ , i.e. the cutter tooth exit angle may vary in a range from  $0^\circ$  to  $90^\circ$ . Since  $w > 2R$ , it is impossible to cover the area in one pass.

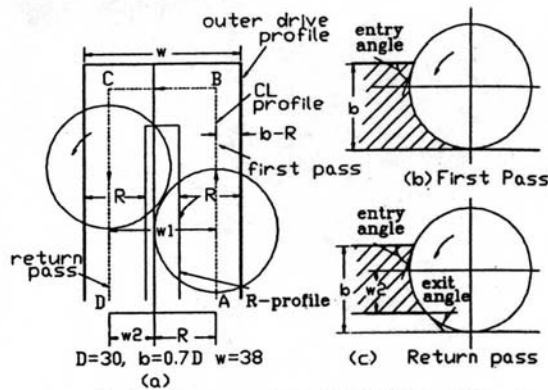

Fig.7 Cutting geometry when the area width is in a range  $2b \geq w > 2R$

**Pattern 2.** When  $2(b-R) < w \leq 2R$ . When using simple offsetting procedures (Fig.8), because the CL profile ABCD exists ( $w \geq 2(b-R)$ ), the cutter will then traverse along the first and the returning passes (AB and CD). Similar to the previous pattern, the cutter tooth exit angle may change considerably even for the first pass, and it is possible that the first pass removes all the material in the area, leaving the second pass to cut air. Note that, since  $w \leq 2R$ , then cutter should be able to machine the whole area with one pass.

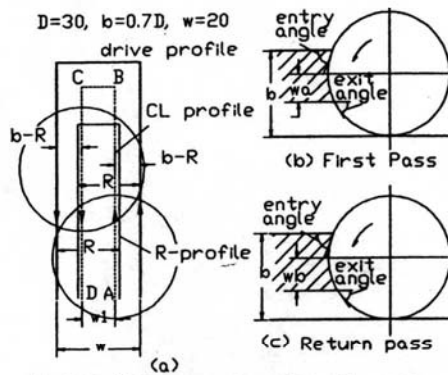

Fig.8 Cutting geometry when the area width is in a range  $2R \geq w > 2(b-R)$

**Pattern 3.** When  $0 < w \leq 2(b-R)$ . This case is shown in Fig.9. The CL profile is twisted (negative) because of the narrow width of the outer drive profile. Traditionally, this CL profile is deleted, and therefore this narrow area will be left un-cut. This problem is caused by large  $b/D$  ratio ( $>0.5$ ).

It can be predicted that keeping favourable entry/exit conditions increases cutter travel length, therefore the entry/exit conditions are considered only when they are necessary. In this work, two methods are developed:

- (1) to keep favourable cutter tooth entry/exit conditions as much as possible while minimising cutter travel distance is considered as well;
- (2) to minimise cutter travel distance as much as possible without considering the entry/exit conditions.

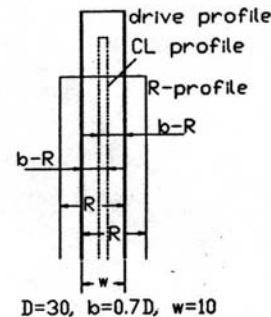

Fig.9 Cutting geometry when the area width is in range  $2(b-R) \geq w > 0$

#### 4. The first method

Assume that, when considering cutting strategies with respect to the cutter tooth entry/exit conditions, down milling is preferred. Obviously, up milling can be achieved by simply reversing the cutter traversing direction on the CL profile.

In Fig.10(a), the basic idea of the first method is shown. ABCD is a drive profile, the area width of this profile is  $w$ , and  $0 < w \leq 2b$ . Suppose the included angles at B and C are not very sharp. XY, YC, and YB are medial axis segments of the drive profile. XY is the trunk of the medial axis diagram of the drive profile. It should be noted that if the cutter cuts tangentially along XY for the first and the returning pass, i.e. the cutter traverses the profile EFGH, the cutter tooth exit angle is then kept as a constant ( $0^\circ$ ). If the cutter rotates counterclockwise, the cutting mode is then kept as down milling.

When there is any sharp corner, compensation is needed. In Fig.10(b), there is a sharp corner at vertex B. Because of this sharp corner, the trunk of the medial axis diagram has to be extended, so that the cutter covers the sharp corner completely when it moves tangentially along the modified trunk. The modification is straight forward. The distance from the junction point Y to each of the corresponding vertices on the drive profile (here B and C) is checked to see whether they are within a circle centred at Y, with a radius of  $D$ . If either of them is outside this circle (B here), then this vertex (B) cannot be covered if the cutter moves to Y only. Hence a further part of the branch (YZ out of YB, where  $ZB=D$ ) is used as an extension of the trunk, hence the cutter paths is extended as well. In Fig.10(b), the CL profile becomes EFLFGHIJK. A minor compensation edge (dual directional) FL is inserted to ensure all the material at corner Y can be removed.

##### 4.1. Covering of the inner-most areas

There is always at least one inner-most drive profile that cannot be offset by a distance  $b$ . A simple example is shown in Fig.11. ABCDEA is the inner-most drive profile, the medial axis diagram is shown as well. Here XYZ is the trunk, XA, XE, YB, ZC and ZD are end branches. For covering an inner-most area, the trunk of the medial axis diagram and if necessary, part of the end branches (to compensate sharp corners) are used to generate the CL profile. In Fig.11, no compensation is required. The R-offset profile (FGHIJKF) for the trunk of the medial axis diagram (XYZ) is then generated as the cutter CL profile to cover the inner-most area. JK is the compensation segment for the corner at Y.

Basically, the maximum area width for the inner-most drive profile is  $2b$  (otherwise a new layer of drive profile can be generated). The trunk of the medial axis diagram divides the area into two parts with equal area widths, so the maximum radial width for

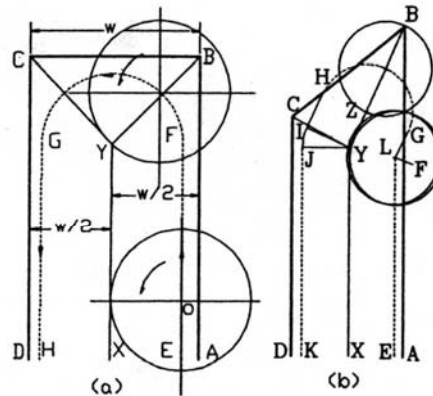

Fig.10 Tool paths around the trunk of the medial axis diagram and compensation edges

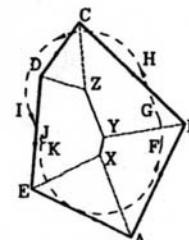

Fig.11 Tool Path for the inner-most drive profile

each cutting pass is  $b$ . Obviously, the cutter can cut a width up to  $D$  on each side, therefore the area can be covered fully.

#### 4.2. Covering of narrow areas enclosed by an intermediate drive profile

Use the example shown in Fig.4. After removing the first two layers of material, to machine the next layer, more cautions should be exercised (Fig.12(a)). There is an area between two drive profiles where the area width varies between 0 and  $2b$ . ABCDEFGA is the outer drive profile,  $A_2 B_2 C_2 D_2 F_2 G_2 A_2$  is the inner-layer drive profile.

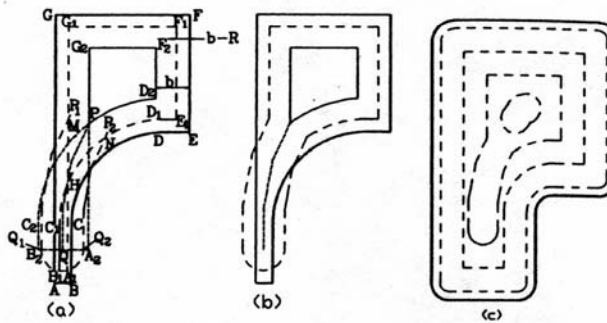

Fig.12 Tool path to machine a L-shaped surface

This inner drive profile intersects itself at point P, loop  $A_2 B_2 C_2 P A_2$  is negative. The cutter is supposed to traverse along CL profile  $A_1 B_1 C_1 D_1 E_1 F_1 G_1 A_1$ . This CL profile is also twisted, a negative loop is generated, i.e.  $A_1 B_1 C_1 H A_1$ . If the cutter simply traverses the valid part of the CL profile, i.e.  $H D_1 E_1 F_1 G_1 H$ , then the cutter leaves some un-cut material, and the cutter tooth exit angle changes considerably as discussed previously.

The method proposed is to use the negative loop of the inner drive profile. The corresponding area enclosed by the outer drive profile can be identified as an area with the width  $0 < w < 2b$ . Hence, the medial axis diagram of such a negative loop is exactly what is of importance.

In Fig.12(a), loop  $A_2 B_2 C_2 P A_2$  is the negative loop of the inner drive profile, its medial axis PQ is used. Based on PQ, the CL profile to cover this narrow area which is the envelope offset of PQ by a distance of R can be obtained, i.e.  $P_1 Q_1 Q_2 P_2$ . These newly generated CL segments must be merged with the valid part of the outer CL profile so that a continuous CL profile can be generated. The merging method is simply selecting the outer envelope profile of these overlapped parts of the CL profile as a whole. In Fig.12(a), the final CL profile after merging is  $Q_1 Q_2 N D_1 E_1 F_1 G_1 M Q_1$ , which is also shown in Fig.12(b). The overall tool path layout for the given example is shown in Fig.12(c).

#### 5. The second method

In this method, cutter tooth entry/exit conditions are not considered, and the cutter travel length should be saved wherever possible. The difference between the first and the second methods occurs only when the area enclosed by the drive profiles has a width ( $w$ ) less than  $2b$ . The basic idea of the second method is that, when  $w \geq 2R$ , the cutter traverses the  $b-R$  offset of the outer drive profile. When  $0 < w \leq 2R$ , the cutter's path is switched to the medial axis of the area, which can be obtained by analysing the negative loop of the R-offset of the drive profile. In Fig.13(a), ABCDE is a drive profile, FGHIJ is the offset of ABCDE by a distance of  $b-R$  ( $b-R$  offset), while KLMNS is the offset of ABCDE by

a distance of  $R$  ( $R$ -offset).  $KLMNS$  intersects itself at point  $T$ , and a negative loop is generated ( $TLMNT$ ). Since the  $R$  offset for this area is negative, then  $0 < w \leq 2R$ .  $TW$  is the medial axis of loop  $TLMNT$ . In Fig.13(b), the cutter is navigated to traverse on the course of  $FUTWXWYWTWVJ$  where  $U$  and  $V$  are the projection points of  $T$  on both sides of the  $b-R$  offset profile, while  $WX$  and  $WY$  are compensation branches for the corner at  $C$  and  $D$  (Fig.13(b)).  $TW$  is the shortest path to cover the narrow area.

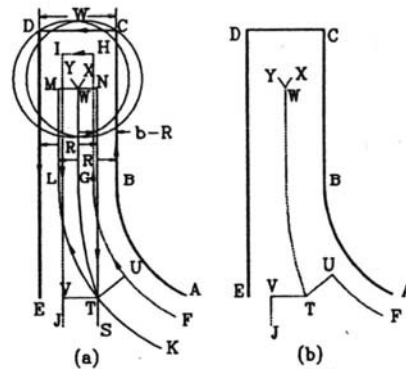
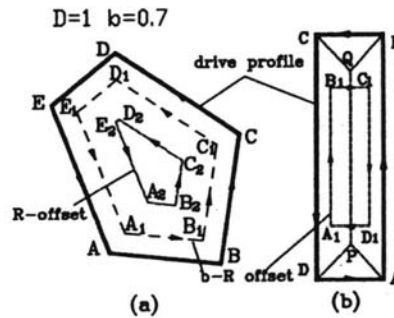

Fig.13 Cutting a narrow area by traversing along the medial axis

### 5.1 Covering of the inner-most areas

The narrow and wide areas in inner-most areas can be detected by generating the  $R$ -offset of the inner-most drive profile. There are three possible cases (Fig.14):

*Case 1:* The  $R$ -offset is valid and there are no negative loops. In this case, as shown in Fig.14(a), the drive profile is  $ABCDEA$ , its  $R$ -offset  $A_2 B_2 C_2 D_2 E_2 A_2$  is positive, then the CL profile to clear the area enclosed by drive profile  $ABCDEA$  is the  $b-R$  offset, i.e.  $A_1 B_1 C_1 D_1 E_1 A_1$ .



*Case 2:* The  $R$ -offset is completely invalid. In this case (Fig.14(b)), since the  $R$ -offset is negative, the area width is less than  $2R$ , therefore, if the cutter traverses along the medial axis of the drive profile, the cutter can cover the whole area in one go. In Fig.14(b),  $A_1 B_1 C_1 D_1$  is the negative  $R$ -offset of the drive profile  $ABCD$ . The medial axis of this area is calculated first. Trunk  $PQ$  is used as the effective CL profile. The compensation for sharp corners has to be considered at the same time.

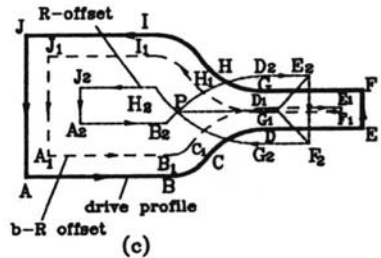

*Case 3:* The  $R$ -offset has positive and negative loops. As illustrated in Fig.14(c), the  $R$ -offset of the drive profile, i.e.  $A_2 B_2 D_2 E_2 F_2 G_2 H_2 J_2$ , intersects itself at point  $P$ . This means that the area corresponding to the positive loop  $PB_2 A_2 J_2 H_2 P$  can not be machined by one cutting pass as the area width is larger than  $2R$ , while the area corresponding to the negative loop  $PD_2 E_2 F_2 G_2 P$  is narrow enough to be covered by one cutting pass.

Based on the above observation, the  $b-R$  offset is used as the CL profile for the wider area; while for the narrower area, the medial axis of the area is used. These two parts of the CL profile are merged by a couple of switch edges, which link the constriction point  $P$  and its nearest points on the  $b-R$  offset on the both sides.

Fig.14 Strategies to deal with innermost drive profiles

### 5.2 Covering of narrow areas enclosed by an intermediate drive profile

In Fig.15(a), a narrow area whose width is less than  $2R$ , is identified by offsetting the drive profile by a distance of  $R$ , the negative loop is given by  $PG_2A_2B_2P$ , where  $P$  is the self intersection point. This narrow area can be machined in a single pass, i.e. driving the cutter along the medial axis of the negative loop, i.e.  $PTU$ . For the compensation of the two sharp angles at  $G$  and  $A$  on the drive profile, two small compensation edges,  $UV$  and  $UW$ , are attached to the end point  $U$  of the medial axis  $PTU$  (Fig.15(b)). Two switch edges,  $PS$  and  $PQ$ , are used to change the cutter's track from the  $b-R$  offset to the medial axis  $PTU$ . They are the shortest edges from  $P$  to the  $b-R$  offset. The final CL profile of this layer is shown in Fig.15(c).

### 6. Conclusion

Using different tool paths for different work materials will smooth cutting process, and improve machining quality and productivity.

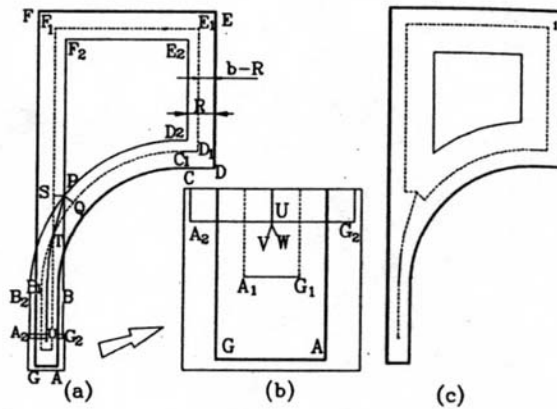

Fig.15 Tool path to machine a narrow area enclosed by an intermediate drive profile

### 7. References

1. G. Barrow, A. K. Ghani and Y. S. Ma, Proc. of 6th IMCC, Hong Kong, March, 1993.
2. M. Held, *On the Computational Geometry of Pocket Machining*, (Springer-Verlag, 1991).
3. A. G. B. Kamaruddin, *Tool Life in Interrupted Cutting*, PhD Thesis, Univ. of Manchester (1984).
4. D. T. Lee, *IEEE Trans. on Pattern Analysis and Machine Intelligence*, No.4, (July 1982).
5. Y. S. Ma, *The Generation of Tool Paths in 2½-D Milling*, PhD Thesis, Univ. of Manchester (1994).
6. H. Opitz and H. Beckhaus, *Ann. CIRP*, Vol.18, (1970) p.257.
7. A. J. Pekelharing, *Ann. CIRP*, Vol.33(1) (1984) p.47.
8. I. Yellowley, *The Development of Machinability Testing Methods with Specific Reference to High Strength Thermal Resistant Work Materials*, PhD Thesis, Univ. of Manchester (1974).