

**Energy optimization of a residential building using occupancy prediction
via sensor fusion and machine learning algorithms**

by

Hamed Heidarifar

A thesis submitted in partial fulfillment of the requirements for the degree of

Master of Science

Faculty of Engineering Department of Mechanical Engineering
University of Alberta

© Hamed Heidarifar, 2023

Abstract

Occupancy-based control systems for floor heating can lead to energy saving in a residential building. This study focuses on the energy consumption by space heating system in a half-duplex residential house located in Edmonton, Alberta. In the first part, a sensor fusion model was designed to predict the occupancy status in the residential building. To predict the occupancy, data including room temperature, relative humidity, CO₂ concentration, and day of the week were collected. The actual occupancy status of the room was collected using a Passive Infrared (PIR) motion sensor and the data sheets filled by the occupants. The study considered four different machine learning algorithms including K-nearest neighbors (KNN), Gaussian Support Vector Machine (SVM), Artificial Neural Network (ANN), and Decision Tree (DT) to predict the state of occupancy for a room. The results showed KNN method outperforms the other methods by reaching the Geometric Mean (GM) accuracy of 92% for occupancy prediction.

In the second part, a 3D energy model was developed for the entire house. The energy consumption was simulated with and without considering occupancy information using EnergyPlus software. The actual energy consumption of the house was obtained from the gas meter. Using the developed model and methods of machine learning, a virtual sensor was proposed to define the thermostat temperature according to the desired temperature in the occupied rooms to reduce energy consumption and improve the comfort level for the occupants. The results showed 9.5% to 30.7% energy saving, depending on the occupancy-based control methods. In addition, the results of the operating analysis showed a possible reduction of the yearly floor heat-

ing cost of the testbed up to 329 CAD which is about 30% reduction in the yearly heating cost of the building. Overall, this study quantized the importance of considering occupancy information in reducing energy consumption in residential buildings, while maintaining or improving the occupants' comfort.

Preface

This thesis is an original work by Hamed Heidarifar. All chapters of this thesis are partially based on two accepted papers in the proceedings of the Canadian Society for Mechanical Engineering International Congress in May 2023 [1, 2]. The initial 3D model of the testbed was created in collaboration with Chaoqun Niu.

To...

my wife, Fatemeh, my parents Manijeh and Mohammad, and my son, Parsa

Acknowledgements

I would like to express my heartfelt gratitude to all those who have supported me throughout the journey of completing my MSc thesis. It is with great pleasure that I acknowledge their invaluable contributions, without which this accomplishment would not have been possible.

First and foremost, I extend my deepest appreciation to my supervisor, Dr. Mahdi Shahbakhti, for his guidance, support, and scholarly expertise. His patience, encouragement, and insightful feedback have been instrumental in shaping my research and refining my academic skills.

I would also like to extend my thanks to my friends, and colleagues at the University of Alberta who helped me with their support throughout this academic pursuit. I would like to specifically thank Chaoqun Niu for his contribution to my project.

I am also profoundly indebted to my wife, Fatemeh Fallahi Arezodar, for her unwavering love, understanding, and constant encouragement. Her presence and belief in my abilities have been my pillar of strength, providing the necessary motivation to overcome challenges and pursue excellence. Her sacrifices and unwavering support have enabled me to dedicate the time and effort required to complete this thesis successfully.

Table of Contents

1	Introduction	1
1.1	Motivation	3
1.2	Literature review	8
1.2.1	Occupancy detection	8
1.2.2	Virtual sensors/thermostat	13
1.3	Thesis Objectives	16
1.4	Thesis Outline	16
2	Experimental setup	18
2.1	Testbed	18
2.1.1	Building information	18
2.1.2	HVAC system	23
2.2	Data collection	26
2.2.1	Sensors setup	26
2.2.2	Real-time data collection of natural gas consumption	31
2.2.3	Summary of data collected	32
2.3	Uncertainty analysis	36
3	3D modeling of the building, energy simulation and validation	38
3.1	Building 3D modeling	40
3.2	Energy model and simulation	45
3.3	Model Validation	47
3.3.1	Natural gas consumption	47
3.3.2	Rooms' temperatures	51
4	Machine learning based occupancy detection	55
4.1	Occupancy detection using environmental data	55
4.1.1	KNN	56
4.1.2	ANN	57

4.1.3	SVM	58
4.1.4	DT	60
4.2	Model performance	63
5	Energy use optimization and control strategies	72
5.1	Energy consumption and occupants comfort level	73
5.2	Different Control Approaches	79
5.2.1	Central heating system, ruled-based control system with building occupancy data	79
5.2.2	Single zone, ruled-based control system with zone occupancy data	86
5.2.3	Multi zone control system with zone occupancy data	90
5.3	Cost saving of different control approaches for energy simulation	94
6	Conclusion & Future Work	96
6.1	Conclusion	96
6.2	Future Work	99
	Bibliography	101
	Appendix A: M.Sc. Publications	109
A.1	Peer Reviewed Journal Papers	109
A.2	Refereed Conference Papers in Proceedings	109
	Appendix B: Thesis Files	110
B.1	Program and Data file Summary	110
B.1.1	Chapter 1	110
B.1.2	Chapter 2	111
B.1.3	Chapter 3	112
B.1.4	Chapter 4	113
B.1.5	Chapter 5	114
B.1.6	Collected data	115
	Appendix C: Sensors Specification	116
C.1	OMEGA WiFi Wireless Temperature and Humidity Data Loggers	116
C.2	Fluke 922 Airflow Meter/ Micro Manometer	124
C.3	Elitech RC-4HC Temperature and Humidity Data Loggers	127
C.4	TD RTR-500-BW Network base station and RTR-576 Wireless CO2 logger	130

C.5 Monnit Wi-Fi Infrared Motion Sensor	135
Appendix D: Experimental Data	138
D.1 Sample of the experimental data	138

List of Tables

2.1	Heating system specifications.	23
2.2	Water heating system specifications.	25
2.3	Nest Thermostat E specifications.	26
2.4	Specification of the sensors used in this study.	28
2.5	Cameras' specifications of the smartphones used for recording the gas meter data and water heater burner status.	32
2.6	The time periods data collected and the number of recorded data samples available for each sensor.	34
2.7	Measured parameters and associated uncertainties.	36
2.8	Derived parameters and associated uncertainties.	37
3.1	Characteristics of different defined thermal zones in the testbed.	41
3.2	Building components properties used in the building model.	43
3.3	Fluke 922 airflow meter technical specification.	46
3.4	Natural gas consumption rate for the space heating and water heating systems when they are On or on Pilot mode. Data was collected on February 19, 2022.	48
3.5	The validation results for room temperatures.	54
4.1	Design parameters of the four classifiers used in this study.	62
4.2	Training time for four classifiers.	67
5.1	Energy consumption and energy saving for the baseline, case 1, case 2, and case 3. All values have been calculated for four weeks between March 21, 2022, and April 17, 2022.	86
5.2	The performance of the ANN models (see Figure 5.8) used to predict the thermostat temperature on April 10, 2022, based on the data collected from the master bedroom, office, and living room between March 21, 2022, and April 9, 2022.	90

5.3	Comparison of energy saving and occupant comfort level in the occupied room(s) between baseline model and virtual sensor model for April 10, 2022.	90
5.4	Heating systems specifications for one unit for the main floor and one unit for the second floor.	91
5.5	Comparison of the energy consumption and energy saving when using two separated heating units (Table 5.4) for the main floor and second floor.	92
5.6	Natural gas usage by the heating system between October 2021 and May 2022.	94
5.7	The total and the breakdown of the heating cost for the house between October 2021 and May 2022.	95
5.8	Comparison of saving on heating cost for different heating system control scenarios.	95
B.1	Chapter 1 Figure files	110
B.2	Chapter 2 Figure files	111
B.3	Chapter 3 Figure files	112
B.4	Chapter 4 Figure files	113
B.5	Chapter 4 Matlab files	113
B.6	Chapter 5 Figure files	114
B.7	Chapter 5 Simulation and Matlab files	114
B.8	Data files	115
D.1	The time periods data collected and the number of recorded data samples available for each sensor.	138

List of Figures

1.1	Comparison of the studies using occupancy detection methods in residential and non-residential buildings. Populated based on data provided in [15].	4
1.2	Comparison of energy consumption in Canadian a) residential and b) commercial and institutional buildings, and c) different energy sources used for space heating in residential buildings [16].	6
1.3	Total energy consumption in Canadian residential households in 2019 based on the type of dwelling. Created based on the data presented in [19].	7
1.4	Classification of the occupancy-based models in the literature.	9
1.5	Different parameters affecting occupancy resolution. Occupancy resolution increases from left to right (Reproduced from [68]).	12
2.1	North view of the house used as the testbed in this thesis.	18
2.2	3D views of the testbed's floors.	20
2.3	Floor layout and supply air registers' locations. All dimensions are in cm.	21
2.4	Gas furnace and water heater that are installed in the basement.	22
2.5	Schematic of the heating system used in the testbed [79].	24
2.6	Sensors used for this study and their images.	29
2.7	The location of the installed sensors in the building	30
2.8	Snapshots of a) The gas meter, b and c) the water heating system's burner status (when the burner is ON blue flame is visible in the video as can be seen on c), and d) Heating system operating condition, used in the project to calculate the real-time natural gas consumption for heating and water heating systems.	33
2.9	Comparison between the outside temperature measured in the backyard and the temperature reported by different weather stations.	35
3.1	The process used to create the building energy consumption model.	39

3.2	Schematic of the thermal zones in the building.	42
3.3	Measuring air velocity for each supply air register.	46
3.4	Experimental validation of the model for simulating the energy consumption for the space heating system compared to measured data for the data collected from April 3, 2022, to April 17, 2022.	50
3.5	Measured temperature against simulated temperature for the foyer, and living room between April 3rd to April 4th, 2022.	52
3.6	Measured temperature against simulated temperature for the master bedroom, and office between April 3rd to April 4th, 2022.	53
4.1	Structure of the classifiers and inputs and output of the model . . .	56
4.2	KNN schematic for 4-nearest neighbors. The algorithm labels the test data based on the labels for the 4 nearest neighbors.	57
4.3	Structure of an ANN model.	58
4.4	SVM schematic.	59
4.5	DT schematic.	61
4.6	Geometric Mean from training set and test set for four algorithms . .	65
4.7	Confusion matrices for occupancy detection test using different ML algorithms with four predictor features (i.e., Temperature, CO ₂ concentration, RH, and Day of the week).	67
4.8	Geometric Mean, while CO ₂ concentration has been removed from predictor features.	69
4.9	Effect of training data size on the performance of the KNN, ANN, DT, and SVM models to predict the room occupancy status.	70
4.10	The performance of models trained using data collected between March 3 rd and April 4 th for predicting occupancy for the seen data ranging from April 4 th to May 7 th	71
5.1	The proportion of the households in the US that use a certain type of thermostat for space heating [98].	74
5.2	Main heating equipment control used in the US households [98]. . . .	75
5.3	Comparison of the thermostat temperature and the temperature recorded by sensors in the entrance (foyer), master bedroom, and office between 11:00 a.m. and 4:28 p.m. on March 31, 2022.	77
5.4	Comparison of the thermostat set temperature and the temperature recorded by sensors in the entrance (foyer) and the master bedroom between 00:00 a.m. and 7:56 a.m. on Nov 7, 2021.	78

5.5	Case 1 and Case 2 thermostat set temperatures between March 21, 2022, and April 17, 2022.	82
5.6	Set temperature for Case 1 and Case 2 on April 16, 2022. This is a zoomed-in view of a day of data from Figure 5.5	83
5.7	Daily energy consumption for the baseline, case 1, case 2, and case 3 between March 21, 2022, and April 17, 2022.	85
5.8	The ANN model layout used to develop the virtual sensor.	88
5.9	The process of energy model simulation for the virtual sensor model.	89
5.10	Daily energy consumption for the baseline, case 1, and two heating units (Table 5.4) for the period from March 21, 2022, to April 17, 2022.	93

List of Symbols

α_i	Lagrange multiplier
\bar{m}	Mean of measured value
θ_{ji}^k	Weight of the neuron "i" in the k^{th} layer connected to neuron "j" in $k+1^{th}$ layer
Acc	Accuracy
d	Euclidean distance
FN	False Negative
FP	False Positive
m	Size of the training set
m_i	Measured value
n	Number of measured data sample
p	Number of adjustable model parameters
RH	Relative Humidity (%)
s_i	Simulated value
S_k	Number of neurons in the k^{th} layer
T	Temperature ($^{\circ}C$)
TN	True Negative
TP	True Positive

Abbreviations

ANN Artificial Neural Network.

ASHRAE American Society of Heating, Refrigerating and Air-Conditioning Engineers.

BEM Building Energy Management.

BMS Building Management System.

CFD Computational Fluid Dynamic.

DOE Department of Energy.

DT Decision Tree.

EU European Union.

FDD Fault Detection and Diagnosis.

GM Geometric Mean.

HMM Hidden Markov model.

HVAC Heating, Ventilation, and Air Conditioning.

KNN k-Nearest Neighbors.

MJ Mega Joule.

MM Markov model.

MP Mega Pixels.

NG Natural Gas.

NMBE Normalized Mean Bias Error.

PIR Passive Infra Red.

PJ Peta Joule.

ReLU Rectified Linear Unit.

RF Radio Frequency.

RMSE Root Mean Square Error.

SVM Support Vector Machines.

VRF Variable Refrigerant Flow.

WiFi Wireless Fidelity.

WLAN wireless local area network.

Chapter 1

Introduction

Residential and commercial buildings are the largest energy-consuming sectors in the world and they are responsible for 40% of all primary energy usage in the US and EU [3]. In Canada, residential and commercial/institutional sectors consume around 30% of the total energy consumption in the country. Among all the energy users in the buildings, space heating and cooling account for 66% and 59% of the energy usage in Canadian residential and commercial buildings, respectively [4, 5]. Despite all the efforts in the building industry to reduce energy consumption and emission production in the building sector, the building industry is still responsible for one-third of the greenhouse gas emissions worldwide [6]. Although new projects such as energy-zero buildings and green buildings have increased energy efficiency, but due to the rapid growth in the building sector, and world population the energy consumption in the building sector is expected to increase globally for the next 30 years by 1.3% [7]. To this end, methods and tools to decrease the energy consumption of buildings

are highly needed.

One of the effective methods in a Building Energy Management (BEM) system to reduce the heating/cooling load of a building is detecting occupancy behavior in a building and adjusting Heating, Ventilation, and Air Conditioning (HVAC) operation accordingly [8]. The temperature range based on human comfort in occupied spaces depends on different parameters such as relative humidity, activity level, clothing, etc. The comfortable temperature for an occupied space varies from 19.5 °C to 27 °C based on ASHRAE 55 standard [9]. In the winter time, when a space in a building is unoccupied, the temperature can be lower than the recommended range in the ASHRAE standard depending on the minimum safe temperature to avoid freezing in a building and the minimum ventilation requirement to avoid forming mold. Although it is difficult to find a unique thermostat temperature for unoccupied buildings during the cold season, the temperature range between 12 °C to 16 °C is commonly used to avoid any damage to the building and save energy [10, 11]. This can reduce the heating load while the building is not occupied; thus, it reduces the building's energy consumption.

Occupancy-based control system in a building can reduce the energy consumption significantly. The study in [12] shows the possibility of up to 80% saving in energy consumption by using an occupancy-based feedback control system. Another study

reported around 30% energy saving by using an occupancy pattern in a conference room of a commercial building [13]. To this end, effective and low-cost methods for occupancy detection are of high interest for buildings. The other parameter that can contribute to the space heating energy consumption in a building is the HVAC control system. According to the study in [14], occupancy-based control systems can be divided into two main categories: user-defined schedule, and occupancy detection and monitoring. The first category relies on the occupancy defined by human and the latter uses different algorithms and techniques to detect occupancy.

This study focuses on developing occupancy detection and monitoring control algorithms and use of sensor fusion-based virtual sensor to minimize building energy consumption. To achieve this goal, the real data is collected from a residential building and plugged into different machine learning algorithms for occupancy detection/prediction, then the occupancy information is used to compare the possible energy saving based on different control policies.

1.1 Motivation

Despite numerous studies conducted for commercial/educational buildings to develop occupancy models, residential buildings have not received the same attention in the literature [15]. Fig 1.1 shows that studies on residential buildings only shape about

20% of the studies in this field.

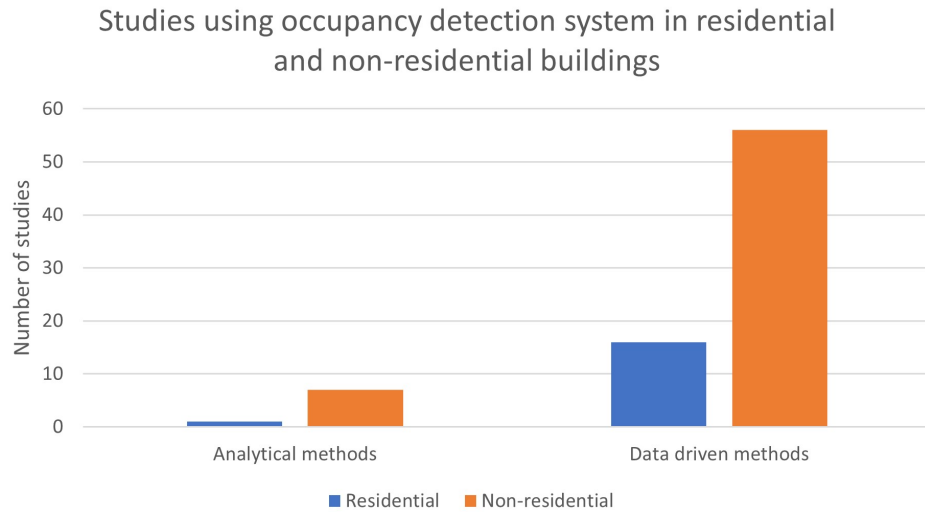

Figure 1.1: Comparison of the studies using occupancy detection methods in residential and non-residential buildings. Populated based on data provided in [15].

The gap in the number of studies on residential compared to non-residential buildings is despite the fact that energy consumed for space heating or cooling in residential buildings is more than that in commercial and institutional buildings and so is the possibility of energy efficiency improvement. Figure 1.2a and 1.2b illustrate energy consumption in both residential and commercial buildings. As can be seen in both residential and commercial buildings space heating accounts for more than 50% of energy consumption in the buildings. In addition, the energy that is utilized for space heating in commercial/institutional buildings is only 60% of the energy used for space heating in residential buildings. Figure 1.2c shows that natural gas is the main source of energy for space heating in residential buildings and in 2018 544 PJ of natural gas

was burned to provide heat for residential buildings in Canada.

Among residential buildings, non-apartment dwellings including, row houses, single detached houses, and duplexes account for 65.5% of the housing in Canada [17]. As presented in Figure 1.3 they consume 88% of the energy in the residential sector. These facts highlight the need for further research on low-cost methods to reduce energy consumption in residential buildings, particularly in non-apartment dwellings. The lack of research in the area of energy optimization on residential buildings despite their share in energy consumption is one of the main reasons that motivated research in this thesis.

In addition, forced air furnace stands for more than 50% of the heating system used in Canadian houses in 2021 [18]. They provide heat for the entire house/apartment based on sensing the temperature at one area of the building which normally is a common location in the building such as the entrance or hall. Although the goal is to install the thermostat in a place that is used by the occupants more frequently, it cannot consider the occupancy of the other zones of the building. This research proposes a virtual temperature sensor and investigates its efficiency to determine the set temperature based on the occupied areas in the building to reduce the heating system's energy consumption.

RESIDENTIAL ENERGY USE, BY TYPE (PJ), 2018

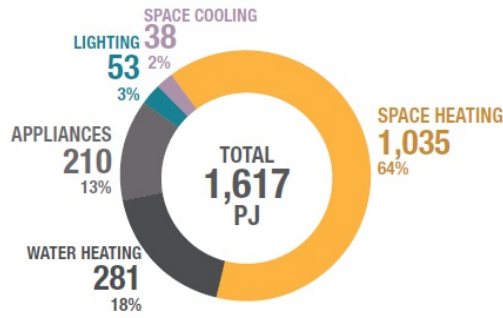

(a) Energy consumption in residential buildings

COMMERCIAL AND INSTITUTIONAL ENERGY USE BY END USE, 2018

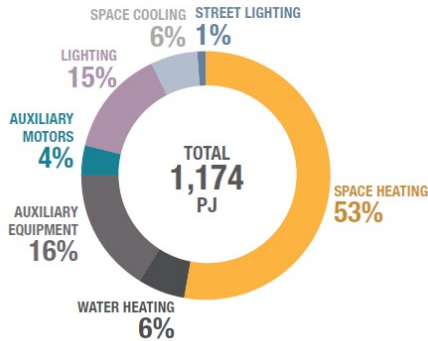

(b) Energy consumption in commercial and institutional buildings

SPACE-HEATING ENERGY USE (PJ), 2018

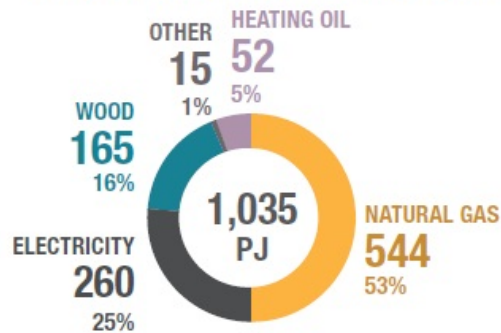

(c) Source of energy consumed for space heating in residential buildings

Figure 1.2: Comparison of energy consumption in Canadian a) residential and b) commercial and institutional buildings, and c) different energy sources used for space heating in residential buildings [16].

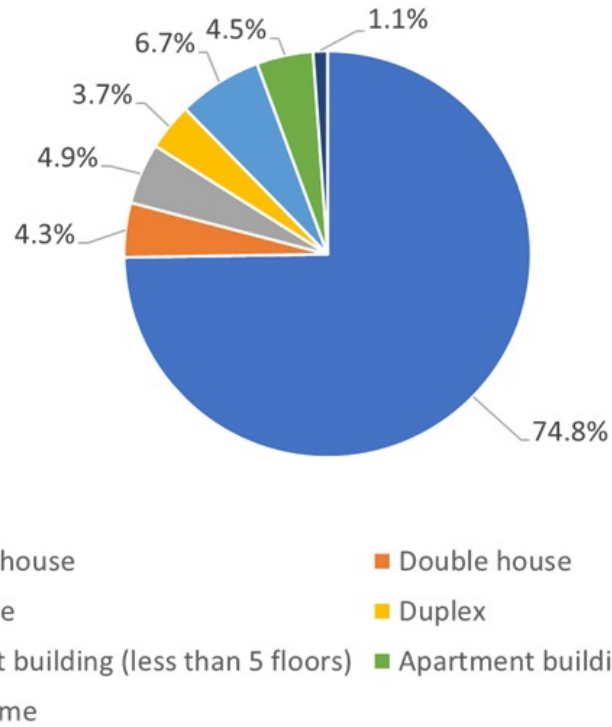

Figure 1.3: Total energy consumption in Canadian residential households in 2019 based on the type of dwelling. Created based on the data presented in [19].

1.2 Literature review

Using occupancy-based algorithms in building management system, has gained more attention from researchers in the past two decades as the information revealed by this method can be used to optimize energy consumption in buildings and design smart grids [15, 20].

1.2.1 Occupancy detection

Fig 1.4 shows the taxonomy of the occupancy-based models in the literature. Implementation of occupancy detection can be divided into two groups: i) occupancy sensing and detection, and ii) occupancy prediction. The former can either be used as a stand-alone method to sense the occupancy in buildings and take control action accordingly or can provide insight to the latter to predict the occupancy for future states [21].

The most basic way to implement the state of occupancy in building energy management is to use manual or programmable thermostats and then let the occupants adjust the set temperature based on their comfort level or occupancy. Although some articles show about 5% energy saving [62, 63], the negative effect on energy saving has been also reported by other researchers due to human intervention in this method [64, 65].

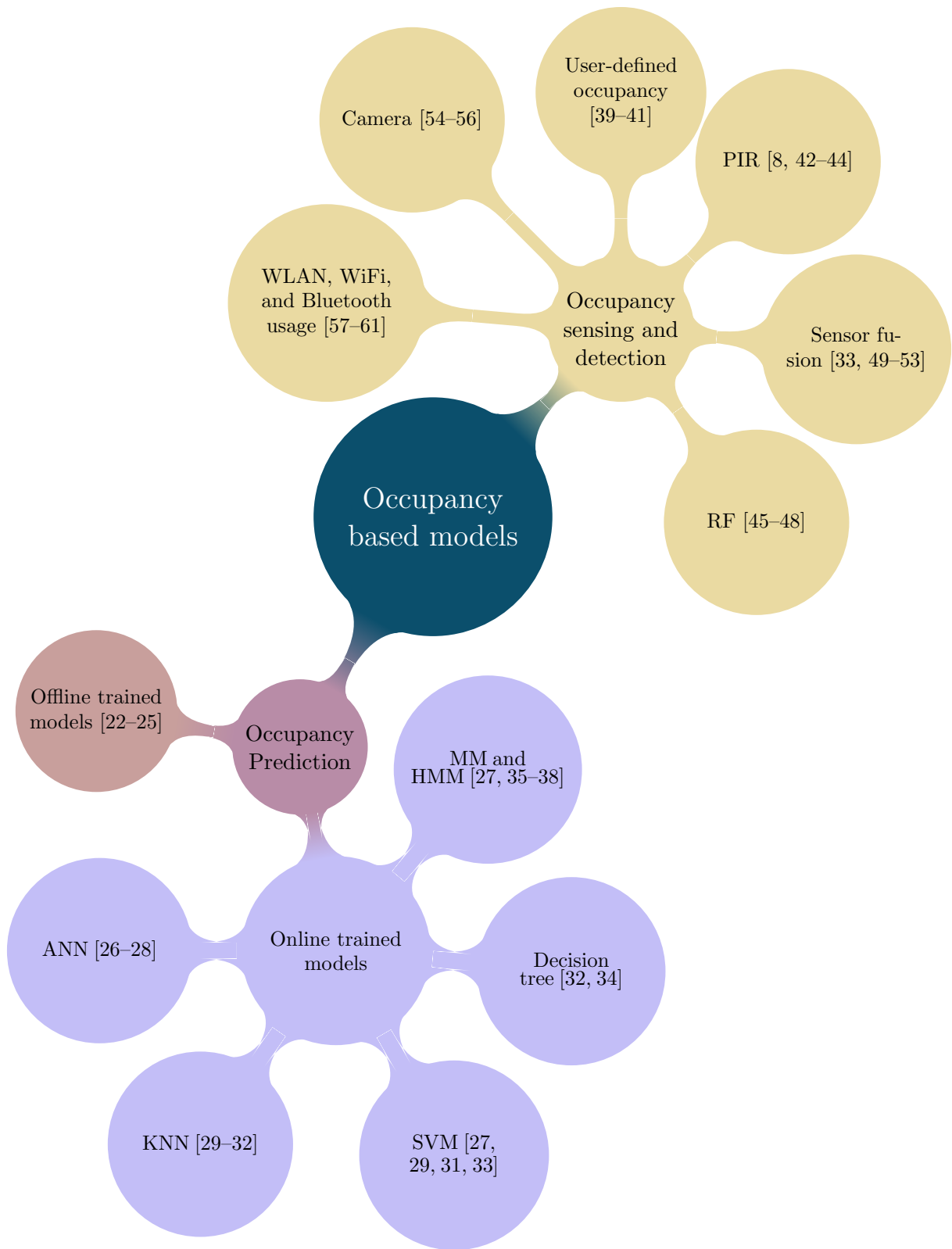

Figure 1.4: Classification of the occupancy-based models in the literature.

There are different methods which can be used to detect the occupancy in buildings without human intervention:

- Video camera
- Passive Infra Red (PIR) motion detection sensor
- Radio Frequency (RF) sensor
- WLAN, Wi-Fi and Bluetooth usage
- Sensor fusion

Among the above-mentioned methods, video cameras, motion detection sensors, sensor fusion, and Wi-Fi usage provide the highest to the lowest accuracy of occupancy detection, respectively [45]. Using a camera provides accurate occupancy information in a range of 95% to 100% [20]. Researchers in [55] used cameras to monitor occupancy for 24h monitoring purposes in a commercial building in Taiwan. In another study, Liu et al. [66] deployed vision sensors to find human heads in the room. Despite the accuracy of cameras, due to strict privacy policies and camera cost, using these methods is not feasible all the time, specifically for residential buildings [8, 20, 67]. Devices, such as laptops or smartphones, connected to a Wi-Fi network have been also used to determine/count occupancy mostly in commercial buildings [57, 58];

however, for residential buildings, its accuracy will decrease significantly since all devices normally connect to one access point despite being in different zones in the house [57]. PIR sensors have been also used in many research studies due to their low cost [8, 42–44]; however, sometimes the lag in the sensor response can cause inaccuracy in the result [20].

RF signal technology is another tool for occupancy detection that has been studied in the building industry [45–48]. It can provide more than 85% accuracy, but it requires a large number of reference points and its accuracy drops when reference points are not sufficient [20]. Using sensor fusion can provide accurate occupancy information for the building control system without creating any privacy issues; however, implementing this method usually needs data from multiple sensors such as CO₂, temperature, humidity, light, etc. Some of these sensors could be expensive for a residential building, but in recent years some of these sensors are already installed in residential buildings for other reasons e.g., safety or being integrated into other smart devices such as smart appliances. The accuracy of the occupancy detection based on sensor fusion methods is highly dependent on the resolution of the data collected from the sensors. As shown in Fig 1.5 occupancy resolution can be improved by collecting more data about the occupants or their activity, considering the smaller time interval for data gathering, and using more sensors to cover a specific area in the building

[68].

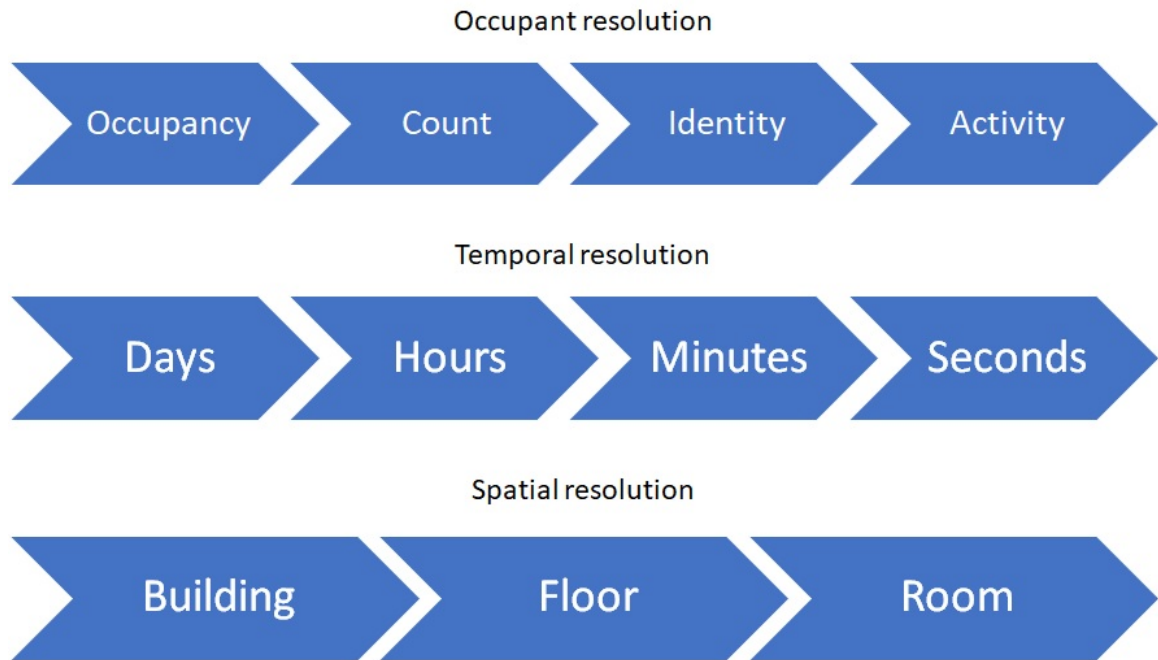

Figure 1.5: Different parameters affecting occupancy resolution. Occupancy resolution increases from left to right (Reproduced from [68]).

The accuracy of studies that combined sensor fusion and data-driven classification models for occupancy prediction varies between 60% to 98% in [15]. A wide range of classification algorithms including Artificial Neural Network (ANN) [26], Support Vector Machine (SVM) [29], K-Nearest Neighbors (KNN) [29, 30], Hidden Markov Model (HMM)[8, 29] and Decision Tree [8] have been implemented in the literature for occupancy prediction.

Hailemariam et al. [34] reported 98% accuracy using the decision tree algorithm

to analyze the data collected from multiple sensors in a public office. Dong et al. [27] used ANN for office space and achieve 75% performance. Other researchers claimed more than 90% accuracy using the same method [32, 69]. Most of the studies that used environmental sensors have a non-residential testbed for their studies and the accuracy of these models on residential buildings need to be studied.

Kleiminger et al. [31] applied SVM model to the data collected from smart meter in a residential building and predicted occupancy with up to 94% accuracy. They reported 92% accuracy using KNN algorithm for the same project. Although using devices such as smart meters can provide good accuracy for occupancy prediction, they normally use a large number of features to train their model. (Kleiminger et al. [31] used 35 features in their research). Another challenge in monitoring electricity consumption for occupancy prediction is that in a situation where occupants don't use electronic devices, these models fail to provide an accurate prediction.

1.2.2 Virtual sensors/thermostat

The idea of using virtual sensors to estimate data from locations that are difficult to measure by the actual sensors started in the early 1980s and then swiftly was implemented in different industries such as process engineering, autonomous robots, and the automotive industry in the late 1990s [70]. The building sector started to

use virtual sensors in the early 2000s for different applications including chillers, heat pumps, and air handling units [70].

Virtual sensors can be used in buildings to provide an accurate estimate of the selected variable by forming a relationship with the data provided by the actual sensors [71]. They can be used for Fault Detection and Diagnosis (FDD) of different equipment in the building. Li et al. [72] used virtual sensors in a decision tree model for fault diagnosis of a variable refrigerant flow (VRF) system. Another study used the virtual sensors method to develop an FDD system to monitor compressor performance, refrigerant charge, fouled condenser, evaporator filter, and faulty expansion device [73]. In addition, virtual sensors can be developed to provide backup for the actual sensors [74–76].

The virtual sensors also were used for energy consumption and monitoring in the buildings. Ploennigs et al. [77] proposed a virtual sensor model to estimate rooms' heating consumption and thermal comfort in a building at University College Cork. They developed their model in a building that is equipped with BMS and provides a wide range of data through the actual sensors installed in the building. Alhashme and Ashgriz [78] used Computational Fluid Dynamics (CFD) to develop a virtual thermostat that controls the HVAC system based on the temperature of the desired room.

The goal of this study is to develop an affordable virtual sensor model for residential buildings without the need for an extensive number of actual sensors that can virtually adjust the main thermostat temperature in the building according to the desired temperature in the occupied areas.

1.3 Thesis Objectives

To address the discussed challenges in Section 1.2, this thesis aims to:

- Propose a low-cost occupancy prediction method that can be used for residential buildings with respect to the privacy of the occupants using machine learning algorithms.
- Develop a virtual sensor in combination with occupancy information to control the building temperature based on occupied zones and required comfort levels.
- Compare different HVAC control policies and their energy saving in a residential building.

1.4 Thesis Outline

Chapter 2 provides information about the experimental setup of the study including the testbed characteristics, sensors placement and the data collected for this study.

In Chapter 3, the process of 3D modeling the building and simulation of the energy modeling is illustrated and the outputs of the model are validated using the measured parameters. Chapter 4 explains different AI models that are used for occupancy prediction and their performance are compared against each other. Next, the occupancy data is used in Chapter 5 to minimize energy consumption in the building. Mul-

tiple control strategies and household savings based on energy prices in Edmonton are studied in this Chapter 5. Finally, Chapter 6 discusses the conclusions from this study, and offer recommendations for future work.

Chapter 2

Experimental setup

In this chapter, the experimental setup for collecting data is explained.

2.1 Testbed

2.1.1 Building information

The testbed in this study is a half-duplex residential house located in the Southwest of Edmonton, Alberta. Figure 2.1 presents the actual image of the house.

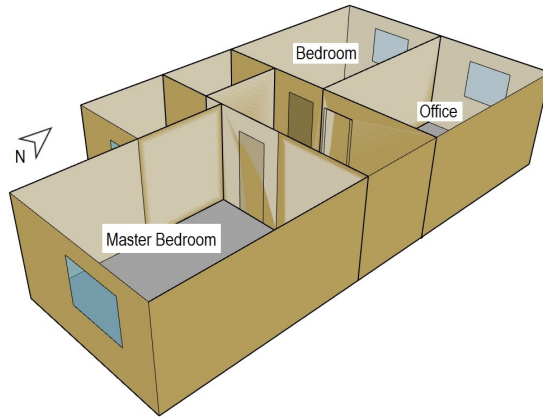

Figure 2.1: North view of the house used as the testbed in this thesis.

As seen in Figure 2.2, the testbed consists of three floors including two residential floors, and a basement. The main floor has a kitchen with an open concept, a living room, a half bathroom, and a foyer. It has access to the basement and garage; however, the doors to those areas were usually closed during the study. Also, the main floor is connected to the second floor through open stairs. The second floor includes three bedrooms and two bathrooms, and a small hall that connects three bedrooms. The basement provides an ample storage area, and it also includes a furnace, water heating system, washing machine, and dryer.

Figure 2.3 depicts the layout of the first and second floors, along with the locations of the floor registers for the supply air coming from the heating system.

The building is equipped with a NEST thermostat E that is installed in the foyer area. It controls the temperature of the building by turning On/Off a TRANE Upflow left-induced draft gas furnace (Model: TUE1B080A9361A) that works with natural gas. Another natural gas consumer in the building is a BRADFORD WHITE water heater that provides hot water for the building. (See Figure 2.4). The specifications of the heating system and water heater are described in Section 2.1.2.



(a) Second floor

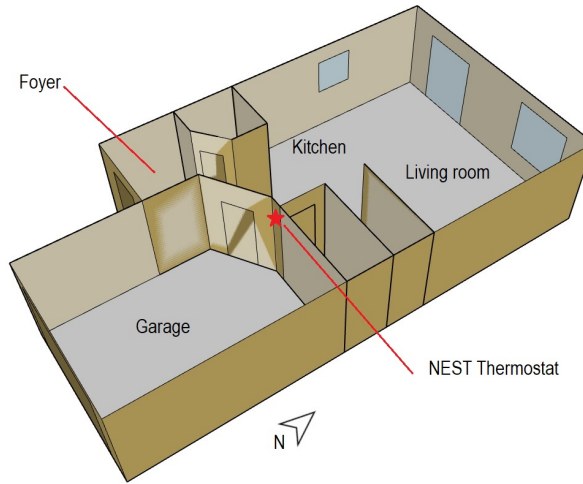

(b) First floor

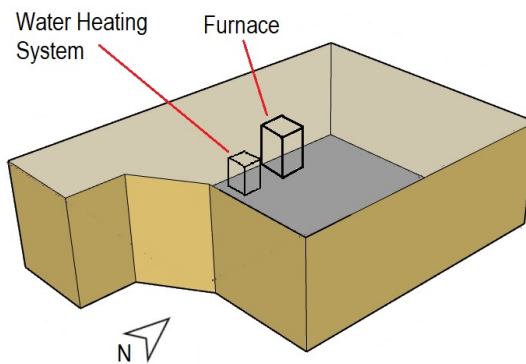

(c) Basement

Figure 2.2: 3D views of the testbed's floors.

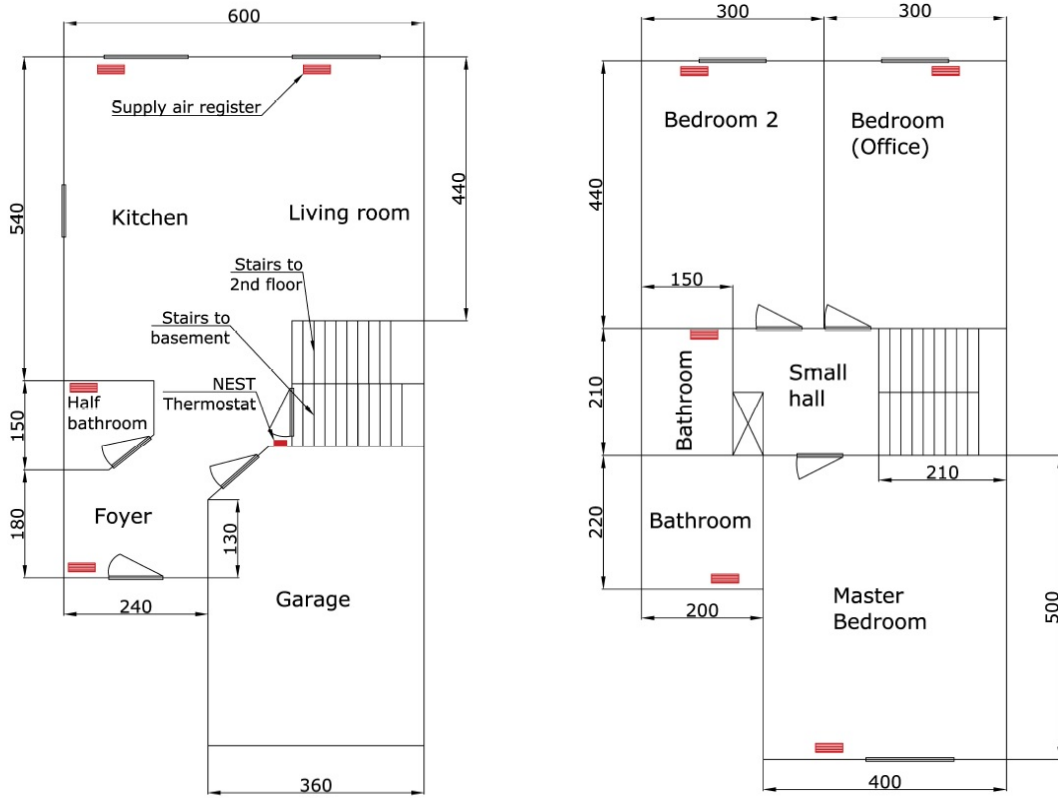

(a) First floor

(b) Second floor

Figure 2.3: Floor layout and supply air registers' locations. All dimensions are in cm.



(a) Gas furnace



(b) Water heater

Figure 2.4: Gas furnace and water heater that are installed in the basement.

2.1.2 HVAC system

The building is equipped only with a heating system that provides heat during the cold season (i.e., September to May). The specification of the furnace is presented in Table 2.1.

Table 2.1: Heating system specifications.

Furnace rating	
Nominal Capacity	84,000 kJ/hour
Actual Capacity	66,500 kJ/hour
Temp.rise (Min.-Max)	16 - 33 °C
Blower Drive	
Motor	0.25 kW
Speed	1075 R.P.M.
Electric Voltage/Phase/Frequency	115/1/60 Volts/Ph/Hz

The furnace burns natural gas with 80% efficiency (Ratio of the actual capacity to nominal capacity) to heat the input air passing through the furnace's heat exchanger. This input air is consists of combination of fresh air and the return air coming back from the building's rooms. Then the warm air is blown to the different regions of the house that have air registers by the blower through the supply air ducting system, and finally, part of the cool air returns to the furnace by the return ducting system. This process is shown in Figure 2.5.

The control system of the furnace is rule-based. It turns the system on when the

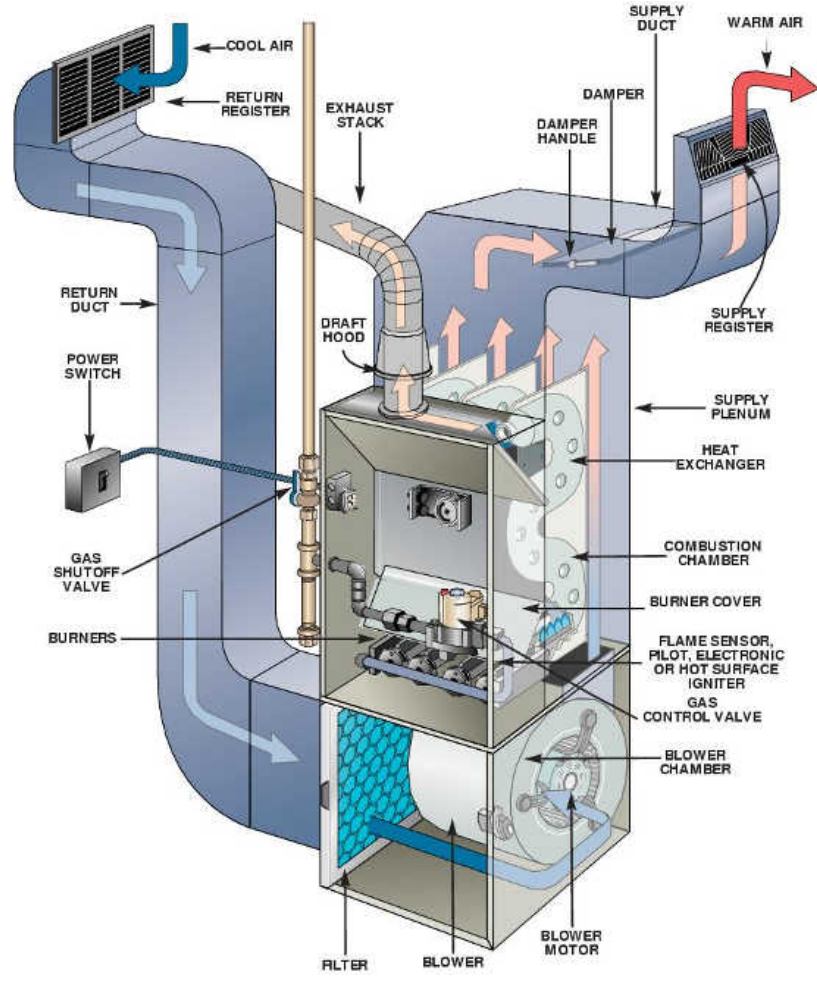

Figure 2.5: Schematic of the heating system used in the testbed [79].

temperature of the NEST thermostat falls 2°C below the set temperature and turns the blower off, and puts the burner on pilot mode (To provide the ignition source for the furnace's burner) when it reaches 2°C above the set temperature. In addition, an automatic storage water heater that works with natural gas supplies the hot water for the building. Specifications for the water heating system are shown in Table 2.2.

The house uses natural ventilation during spring and summer, and the temperature is controlled by adjusting windows and doors based on the outside noise and

Table 2.2: Water heating system specifications.

Water heating rating	
Input	37,980 kJ/hour
Capacity	0.15 (m ³)
Working pressure	1030 kPa

occupants' comfort level.

2.2 Data collection

2.2.1 Sensors setup

As described before, a NEST thermostat controls the heating system in the building. The specifications of this thermostat are presented in Table 2.3. This thermostat is equipped with a motion sensor to detect occupancy and decrease the set temperature automatically during no occupancy. However, it only collects the occupancy information in its surrounding area, part of the main floor, not the entire building. The algorithm or data collected by this thermostat were not available to the user.

Table 2.3: Nest Thermostat E specifications.

Google Nest Thermostat E 	
Sensors	Temperature, Humidity, Proximity, Motion, Ambient light, Magnetic (for thermostat ring position)
Memory	256 MB
Operating	Temperature: 0°C to 40°C (32°F to 104°F) Humidity: Up to 90% RH unpackaged Pressure: Up to 10,000 ft altitude
Compatibility	The Nest Thermostat E works with 85% of 24 V heating and cooling systems, including gas, electric, forced air, heat pump, radiant, oil, hot water, solar and geothermal.

Multiple sensors were placed on the testbed to collect the required data for this study. These sensors and their specification are listed in Table 2.4 and their images are shown in Figure 2.6. In addition, the sensors' catalogs are presented in Appendix C. In addition to the NEST thermostat, two Monnit wireless PIR motion detection

sensors were installed on the first and second floors to track the occupancy activity in the building. The PIR sensor on the main floor can cover the entire main floor including the kitchen and living room while they are occupied. In addition, two Omega temperature/humidity loggers were placed in the living room and foyer to collect the data from the first floor (Figure 2.7a). Two of the three bedrooms on the second floor were mostly occupied during nights (Master bedroom and bedroom in Figure 2.7b), but the other one (Office) was used for other purposes and could be occupied during days. The bedroom that was used as an office was equipped with the second PIR sensor. As this room was mainly occupied during the day and the state of occupancy was more diverse than the other bedrooms, a T and D CO₂ recorder was placed in this room to collect the CO₂ concentration, temperature, and relative humidity. These data later were used to investigate the occupancy prediction using environmental data. For the other bedrooms on the second floor, an Omega and an Elitech temperature/humidity loggers were used to measure the temperature and relative humidity in the master bedroom and bedroom accordingly (Figure 2.7b).

Table 2.4: Specification of the sensors used in this study.

Sensor	Quantity	Placed in	Measures	Range	Accuracy	Resolution	Recording interval
T AND D Wireless CO2 recorder RTR 576, and Network Base Station RTR500BW	1	Bedroom (Office)	CO2 Concentration	0 to 9999 ppm	$\pm(50 \text{ ppm} + 5\% \text{ of reading})$ at 5,000 ppm or less	Minimum of 1 ppm	1 minute
			Relative Humidity	10 to 95%	5 %RH at 25 °C, 50 %RH	1 %RH	
			Temperature	0 to 55 °C	$\pm 0.5 \text{ }^\circ\text{C}$	0.1 °C	
Omega WiFi Wireless Temperature and Humidity Data Loggers OM-EL-WIFI-TH	3	Master bedroom, Living room, and Foyer	Relative Humidity	0 to 100%	$\pm 2.5\% \text{ RH}$ typical (20 to 80% RH)	1 %RH	1 minute
			Temperature	-20 to 60 °C	5 to 60 °C; $\pm 0.3 \text{ }^\circ\text{C}$	0.5 °C (1.0 °F) display; 0.1 °C (0.18 °F) recorded	
			Movement	Within 5 m	NA	NA	
Monnit Wi-Fi Infrared Motion Sensor	2	Bedroom (Office) and Living room					1 minute
Elitech RC-4HC Digital Temperature and Humidity Data Logger	2	Bedroom 2 and Deck (Outside)	Relative Humidity	0 to 99%	$\pm 3\% \text{ RH}$ (25 °C, 20 90 %RH)	0.1 %RH	1 minute
			Temperature	-30 to 60 °C	$\pm 0.6 \text{ }^\circ\text{C}$ (-30 °C 60 °C)	0.1 °C	



T AND D Wireless CO2 recorder RTR-576



T AND D Base station RTR500BW



Omega Wi-Fi Wireless Temperature and Humidity Data Loggers OM-EL-WIFI-TH



Monnit Wi-Fi Infrared Motion Sensor



Elitech RC-4HC Digital Temperature and Humidity Data Logger



Google Nest Thermostat E

Figure 2.6: Sensors used for this study and their images.

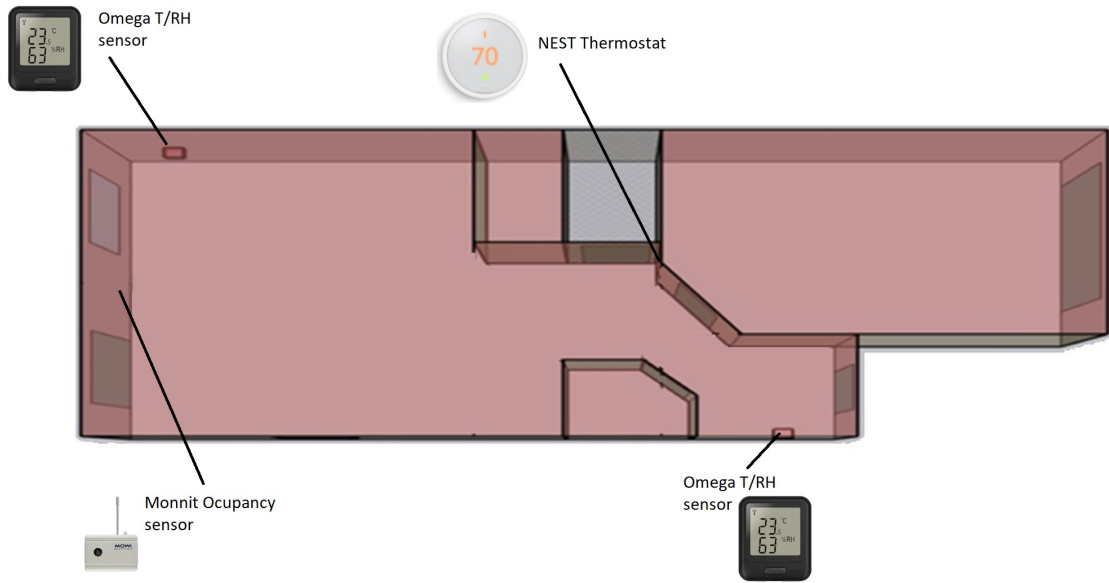

(a) First floor

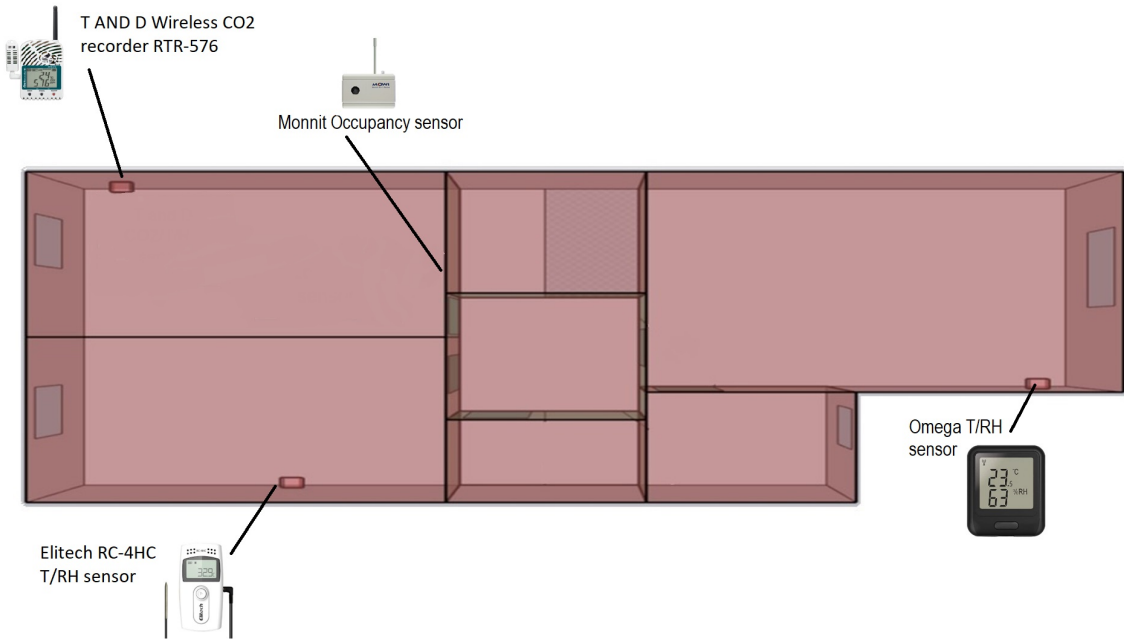

(b) Second floor

Figure 2.7: The location of the installed sensors in the building

2.2.2 Real-time data collection of natural gas consumption

The main heating energy consumption includes the use of natural gas in the house gas furnace and the water heater. To measure real-time natural gas consumption accurately, two smartphone cameras, one iPhone 5s, and one Samsung S8+, recorded videos of the gas meter of the house and the burner of the water heating system. The specifications for both smartphones' cameras are listed in Table 2.5.

The first camera recorded the real-time natural gas consumption in the house (Figure 2.8a). The gas meter measures the natural gas consumption in ft^3 . The last two digits should be read from the two clock-style registers. Each spin on the left register shows half a cubic foot and on the right one count two cubic foot. The second camera recorded the state of the water heating system burner at each time (Figure 2.8b). Both heating and water heating systems have only two states, ON or Pilot. When the burner is in the Pilot state, it is not completely OFF, but it only consumes a low amount of energy and makes it easier to turn the burner ON again when the heat is needed. The actual natural gas consumption by these systems was calculated by comparing and syncing the recorded videos and the state of the heating system's furnace, provided by the NEST thermostat (Figure 2.8c). The bars illustrate the time that furnace was on and the numbers inside the circles show the

set temperature for the thermostat.

Table 2.5: Cameras' specifications of the smartphones used for recording the gas meter data and water heater burner status.

Device	Camera specifications
iPhone 5S	8 MP with 1.5 μ pixels f/2.2 aperture
Samsung S8+	12 MP, f/1.7, 26mm (wide)

2.2.3 Summary of data collected

The data collection process for this study began in July 2021 and finished in May 2022. Because not all the sensors listed in Table 4 were installed in the testbed simultaneously, the number of sample data collected by each sensor is different. The data collection periods and sample data for each sensor are presented in Table D.1. In total, 814935 data samples were collected for this thesis. A sample of collected data is shown in AppendixD.

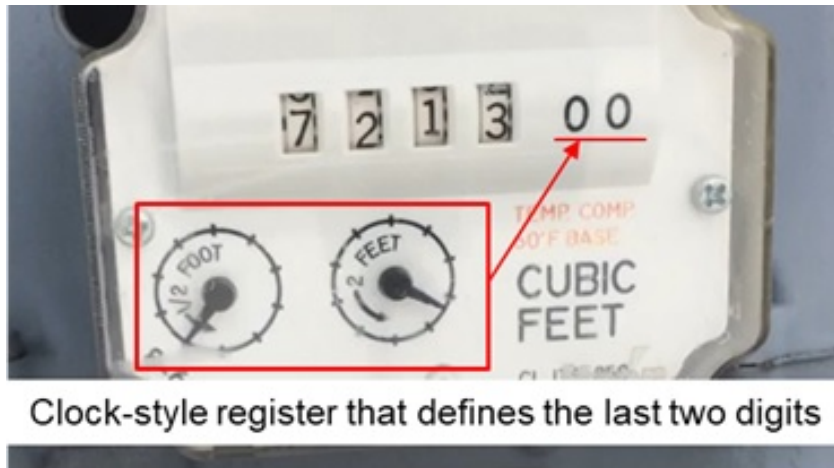

(a) Gas meter

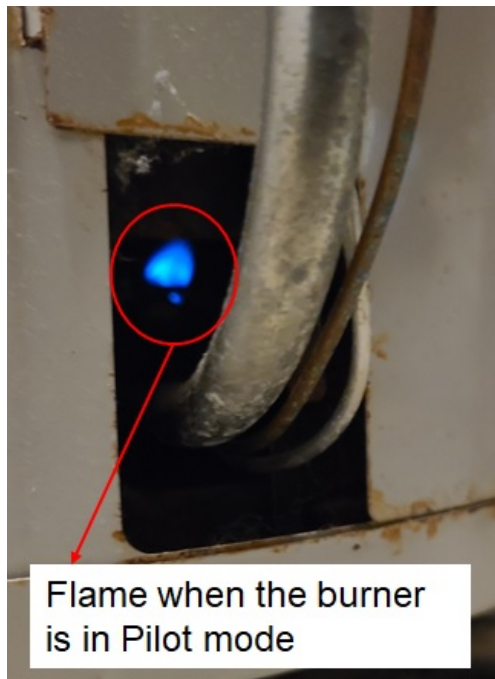

(b) Water heating system's burner Pilot



(c) Water heating system's burner On

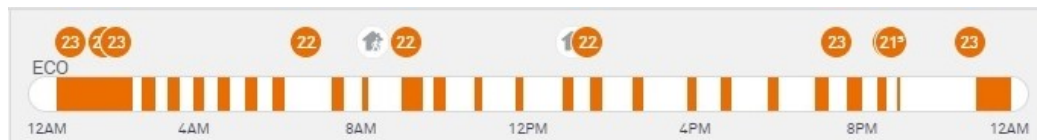

(d) NEST thermostat snapshot showing the furnace operating time. The numbers inside the circles show the set temperature for the thermostat.

Figure 2.8: Snapshots of a) The gas meter, b and c) the water heating system's burner status (when the burner is ON blue flame is visible in the video as can be seen on c), and d) Heating system operating condition, used in the project to calculate the real-time natural gas consumption for heating and water heating systems.

Table 2.6: The time periods data collected and the number of recorded data samples available for each sensor.

Sensors	Data collection period(s)	Available sample data
T and D Wireless CO2 Recorder	July 1st, 2021 to October 26th, 2021 February 14th, 2022 to May 31st, 2022	254300
Omega WiFi Wireless Temperature and Humidity Data Loggers	July 1st, 2021 to April 14th, 2022	403670
Monnit Wi-Fi Infrared Motion Sensor	March 3rd, 2022 to May 31st, 2022	129600
Elitech RC-4HC Digital Temperature and Humidity Data Logger	April 14th, 2022 to May 3rd, 2022	27365

The data collected from the Elitech sensor installed outside of the house was used to verify that the weather information retrieved from the weather stations was reasonably close to the outside temperature around the house. Figure 2.9 compares the measured temperature for the outside temperature and the temperature reported by different weather stations.

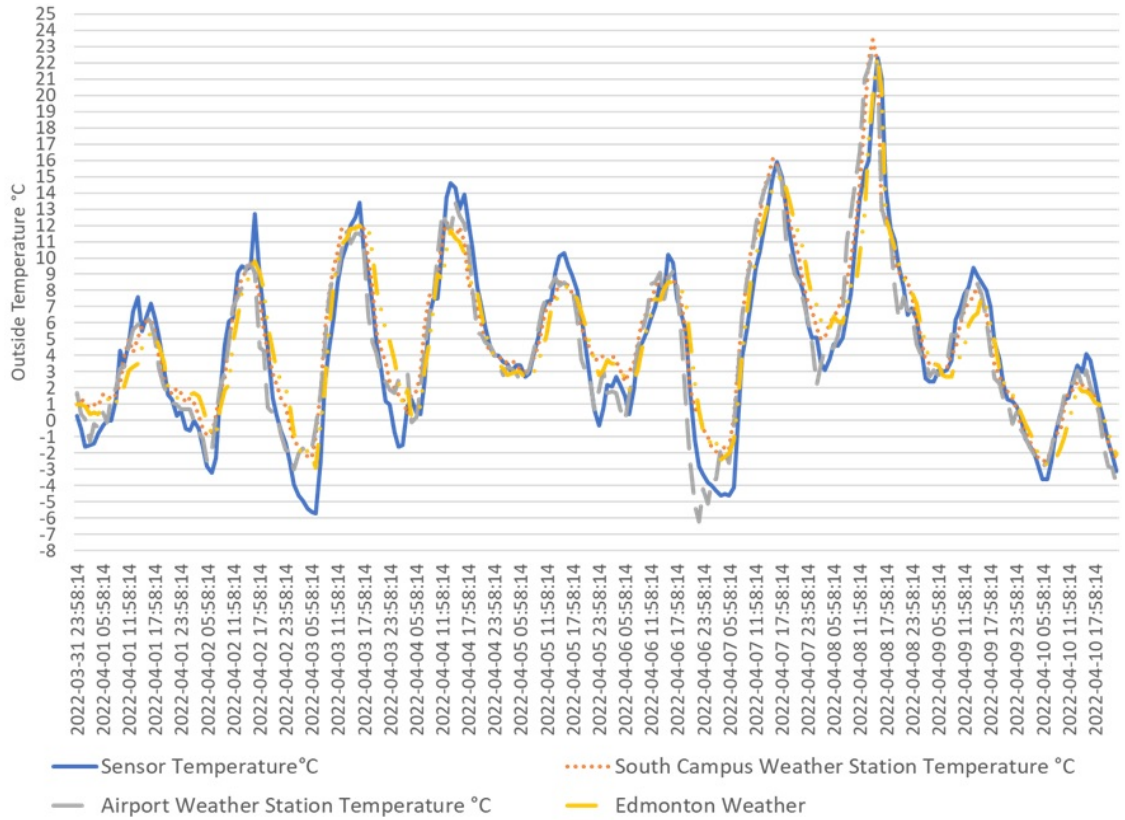

Figure 2.9: Comparison between the outside temperature measured in the back yard and the temperature reported by different weather stations.

2.3 Uncertainty analysis

For this study, different data were collected by multiple sensors. The uncertainty associated with the measurement process and measurement devices can affect the conclusion. The uncertainties for the measured parameters used in this study are documented in Table 2.7. The propagated uncertainty for a derived parameter Y in Equation(2.1) can be calculated according to Equation(2.2) [80].

$$Y = f(X_1, X_2, \dots, X_n) \quad (2.1)$$

$$U_Y = \sqrt{\sum_i \left(\frac{\partial Y}{\partial X_i} \right)^2 U_{X_i}^2} \quad (2.2)$$

Where, Y is the calculated parameter, X is the measured parameter, U_Y is the uncertainty in the derived parameter, and U_X is the uncertainty in the measured parameter. The uncertainties for the calculated parameters are listed in Table 2.7.

Table 2.7: Measured parameters and associated uncertainties.

Parameter [Unit]	Value	Uncertainty
Temperature [°C]	10 - 40	±0.3 to ±0.6
Relative Humidity [%]	5 - 40	±2.5% to ±5%
CO2 Concentration [ppm]	200 -1300	±60 to ±115
Natural gas consumption [ft ³]	0.05 - 20.4	± 0.05
Supply air register dimension [m]	0.1 - 0.3	± 0.001
Supply air velocity [m/s]	2.5 to 6	± 2.5%

Table 2.8: Derived parameters and associated uncertainties.

Parameter [Unit]	Value \pm Uncertainty
Natural gas flow rate [ft ³ /hr]	85 \pm 3.5
Air flow rate @ office [m ³ /s]	0.064 \pm 0.008
Air flow rate @ Master bedroom [m ³ /s]	0.075 \pm 0.008
Air flow rate @ Foyer [m ³ /s]	0.114 \pm 0.015
Air flow rate @ Kitchen [m ³ /s]	0.1375 \pm 0.015
Air flow rate @ Living room [m ³ /s]	0.105 \pm 0.011
Air flow rate @ Bedroom 2 [m ³ /s]	0.06 \pm 0.008
Air flow rate @ Washrooms [m ³ /s]	0.015 \pm 0.002

Chapter 3

3D modeling of the building, energy simulation and validation

As explained in 2.1 the testbed of this study is equipped with a heating system and there wasn't any possibility to make changes in the heating unit or its control system. To be able to apply different control strategies and compare their performances together, an energy model of the building and its heating system is needed. This model can be used to calculate energy consumption and temperature profile in the building.

There are different tools in the market that can be used for building energy modeling including EnergyPlus, TRNSYS, and TRACE 3D Plus. EnergyPlus is a free, open-source program developed with the funding from U.S. Department of Energy (DOE) that can be used for whole-building energy simulation [81]. TRNSYS is a modular program developed by researchers at the University of Wisconsin Madison that can be used for applications such as solar systems, HVAC, and renewable energy systems [82]. TRACE 3D Plus is another building design and analysis software de-

veloped by TRANE Co. It is built on EnergyPlus and can be used to model building and its HVAC system [83].

In this study, EnergyPlus and its graphical interface, OpenStudio were utilized to create the building energy model as they are open source software and widely used for energy simulation of the buildings. In addition, all the required details for the energy simulation can be added to these software. The 3D model of the building was created using Sketchup, and this model was then imported into OpenStudio to specify building envelope parameters, weather information, number of occupants, occupancy schedule, equipment, and their schedule, lighting, and HVAC system. Finally, EnergyPlus was used to solve the energy model and calculate the energy consumption in the building. This process is shown in Figure 3.1. In the next three sections, more details about these steps are provided.

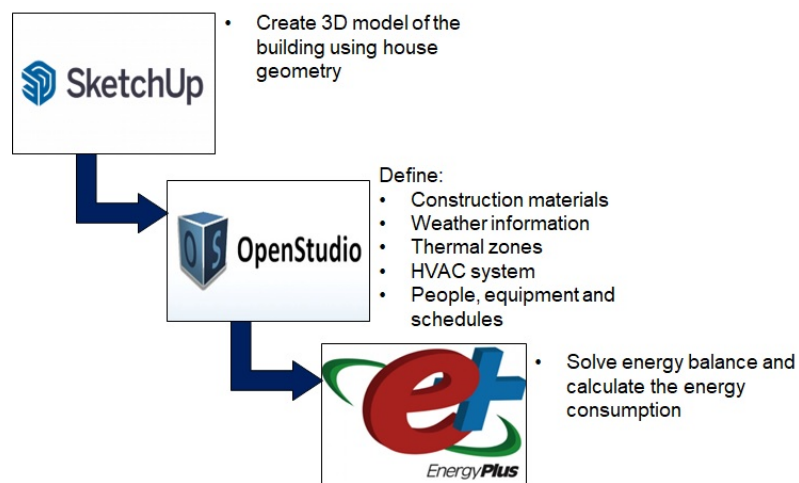

Figure 3.1: The process used to create the building energy consumption model.

3.1 Building 3D modeling

To create the 3D model that is required for the energy model, the building dimensions were measured and a 2D model was created in AutoCAD. After that, the 2D model was used to create the 3D model of the building using SketchUp. Sketchup was selected as the software to create the 3D model because there is a built-in OpenStudio add-on that can be installed to define the building's thermal characteristics for EnergyPlus. To be able to track the temperature in different rooms, the building was divided into different zones to make sure the temperature of different areas can be extracted from EnergyPlus's reports. Three zones were separated from others as there was no heating in those areas (Basement, roof, and garage). Having sensors installed in an area or having separated supply air grills were other parameters that were considered for zoning the building. The characteristics of each area are listed in Table 3.1. The NEST thermostat is installed in the Foyer. The bedroom (Office) that is equipped with a CO₂ and motion detection sensor was used to develop the occupancy prediction model. All thermal zones are shown in Figure

Table 3.1: Characteristics of different defined thermal zones in the testbed.

Area (Thermal Zone)	Surface (m²)	Volume (m³)	Air conditioned (Y/N)
Basement	44.03	107.36	No
Bathroom master bedroom	4.4	10.73	Yes
Bathroom second floor	3.15	7.68	Yes
Bedroom (Office)	13.2	32.19	Yes
Bedroom 2	13.2	32.19	Yes
Foyer	7.07	17.25	Yes
Garage	19.37	47.23	No
Half bathroom main floor	2.03	4.94	Yes
Hall	5.25	12.8	Yes
Kitchen	19.98	48.72	Yes
Living room	10.12	24.68	Yes
Master bedroom	20	48.77	Yes
Roof	71.86	10	No
Stairs	2.3	22.02	Yes
Total (conditioned area)	100.7	309.19	

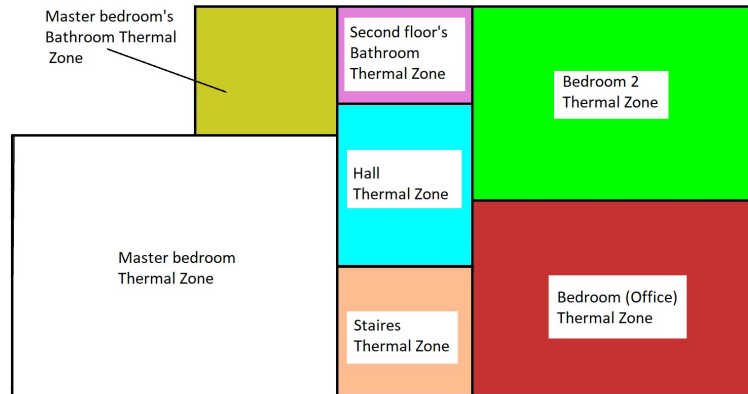

(a) Second floor

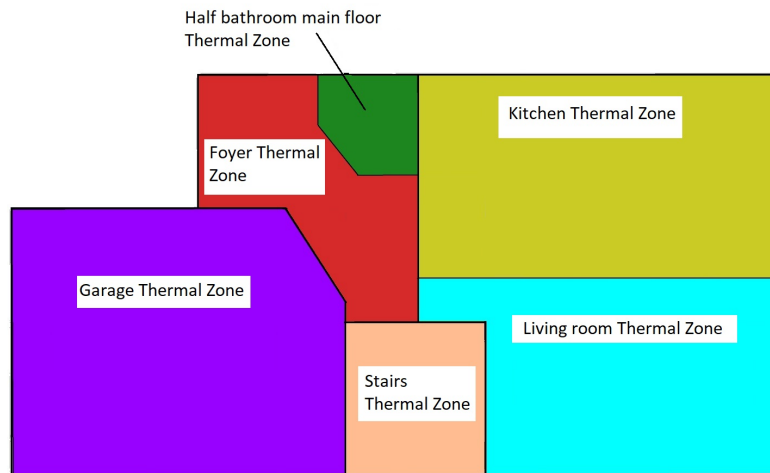

(b) First floor

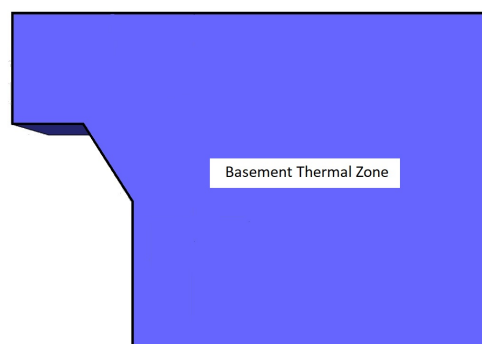

(c) Basement

Figure 3.2: Schematic of the thermal zones in the building.

The materials that were used to model the building envelope have been listed in Table 3.2. Due to the lack of access to the construction documents of the building, one of the construction sets of the EnergyPlus library that complies with ASHRAE 198.1 2009 standard for climate zone 3 is used to define the building's materials.

Table 3.2: Building components properties used in the building model.

Building component	Material Layers	Thickness (m)	Thermal conductivity (W/(m.K))
Exterior walls	1IN Stucco	0.025	0.692
	8IN Concrete	0.203	1.730
	Wall Insulation-36	0.057	0.043
	1/2IN Gypsum	0.013	0.160
Exterior floors	4 HW Concrete	0.102	1.311
	CP02 Carpet Pad	0.010	0.100
Exterior roofs	Membrane	0.010	0.160
	Insulation-21	0.211	0.049
	Metal Decking	0.002	45.006
Interior walls	G01a 19mm gypsum board	0.019	0.160
	F04 Wall air space resistance	0.020	0.134
	G01a 19mm gypsum board	0.019	0.160
Interior floors	F16 Acoustic tile	0.019	0.060
	F05 Ceiling air space resistance	0.020	0.112
	M11 100mm lightweight concrete	0.102	0.530
Ground floors	4 HW Concrete	0.102	1.311
	CP02 Carpet Pad	0.010	0.100
Windows	Theoretic Glass-202	0.003	0.0192
Doors	F08 Metal surface	0.001	45.280
	I01 25mm insulation board	0.025	0.030

EnergyPlus calculates the radiation based on the location of the building and the weather file provided by the user. Data from the Edmonton South Campus weather station [84] were used as the weather source in this study. Conduction from the outside of each zone through building elements, convection to the air in each zone, shortwave radiation from solar through windows, and longwave radiation from other sources in the zone will be considered in EnergyPlus to solve the heat balance equation in each zone [85].

3.2 Energy model and simulation

After creating 3D model of the building, it was imported into OpenStudio. The building that is used in this study shares the east wall with its neighbor (Figure 2.1) and is exposed to the outside air from the other sides. As the temperature of the neighboring building cannot be monitored, it has been assumed that there is not a significant difference between the temperature in both buildings; thus, during simulation, the east wall has been defined as an adiabatic wall (no heat transfer between both sides of the wall). In the testbed, basement, garage, and roof area didn't receive any heat directly from the furnace and were not considered as the conditioned area. In total, there are 39.2 m² of conditioned surface on the main floor and 61.5 m² on the second floor.

To be able to create an accurate energy model of the building the airflow provided by the heating system at each zone needs to be known. Thus, the dimensions, air velocity, and flow rate of each supply air register were measured (Figure 3.3). To measure the air velocity a Fluke 922 airflow meter was used. Table 3.3 presents the specification of the airflow meter. This information was used to calculate the airflow rate for each air supply register and then the results were inserted into the EnergyPlus model. The locations of all air supply registers were previously shown in Figure 2.3.



Figure 3.3: Measuring air velocity for each supply air register.

Table 3.3: Fluke 922 airflow meter technical specification.

	Range / Resolution / Accuracy
Air pressure	±4000 Pascals / 1 Pascal / ±1% + 1 Pascal
Air velocity	1 to 80 m/s / 0.001 m/s / ±2.5% of reading at 10.00 m/s
Air flow (volume)	0 to 99,999 / 1 m ³ /hr / Accuracy is a function of velocity and duct size
Temperature	0°C to 50°C / ±1% + 2°C / 0.1°C

3.3 Model Validation

To validate the model, two metrics including Normalized Mean Bias Error (NMBE) and Root Mean Square Error (RMSE) are used to compare the accuracy of the simulation with real data collected from the building [86]. According to different documents, including Federal Energy Management Program (FEMP), and ASHRAE guideline 14, NMBE between -10% and +10%, and RMSE less than 30% are acceptable for simulation of an energy model [86].

$$NMBE = \frac{1}{\bar{m}} \times \frac{\sum_{i=1}^n (m_i - s_i)}{n - p} \times 100\% \quad (3.1)$$

$$RMSE = \frac{1}{\bar{m}} \times \sqrt{\frac{\sum_{i=1}^n (m_i - s_i)^2}{n - p}} \times 100\% \quad (3.2)$$

Where, m_i is the measured value, s_i is the simulated value, \bar{m} is the mean of measured values, n is the number of measured data sample, and p is the number of adjustable model parameters which are considered to be zero in Equation (3.1) and is equal to one in Equation (3.2).

3.3.1 Natural gas consumption

By syncing the data collected from the water heating system's burner and the space heating system's burner, four distinct periods of natural gas consumption are defined:

1. Space Heating system and Water Heating system On
2. Space Heating system On, Water Heating system on Pilot
3. Space Heating system on Pilot, Water Heating system On
4. Space Heating system and Water Heating system on Pilot

Finally, the natural gas consumption rate for each of these periods was calculated by considering the recorded videos of the gas meter. These rates can be seen in Table 3.4.

Table 3.4: Natural gas consumption rate for the space heating and water heating systems when they are On or on Pilot mode. Data was collected on February 19, 2022.

Start time	End time	Space heating system status	Water heating system status	Natural gas Consumption (ft ³)	Duration (min)	Consumption rate (ft ³ /hr)
10:05	10:12	On	Pilot	9.0	7	77
10:12	11:36	Pilot	Pilot	0.7	84	0.5
11:36	11:52	Pilot	On	9.0	15.5	34.8
11:52	11:54	On	On	5.0	2.5	120
11:54	12:05	On	Pilot	18	14	78
14:30	14:31	On	On	0.95	0.5	114
14:31	16:29	Pilot	Pilot	0.65	118	0.3
16:29	16:30	On	Pilot	1.4	1	84
16:30	16:41	Pilot	Pilot	0.05	11	0.3
16:41	17:15	Pilot	On	20.4	33	37

Because the natural gas consumption rate of the heating units is fixed, for a 15-day period between April 3, 2022, and April 17, 2022, the rates in Table 3.4 were used

to calculate the heating systems' natural gas consumption on a daily basis. Then NMBE and RMSE were calculated to find the accuracy of the simulation model. Fig. 6 compares the energy consumption for the heating system based on the measured data and the result of the energy model. Both NMBE and RMSE satisfy the criteria of acceptance of the model (see Section 3.3) and show that the energy model simulates the energy consumption in the building with good accuracy with NMBE of 2% and RMSE of 9%. The gap between measured consumption and the simulation result on April 8, 2022, is due to the unusual commute to the backyard from the kitchen that was not possible to capture through the energy model. The increase and decrease in energy consumption are mostly affected by the outside temperature (e.g., as the outside temperature decreased between April 9 and April 17, the energy consumption has been increased in the building).

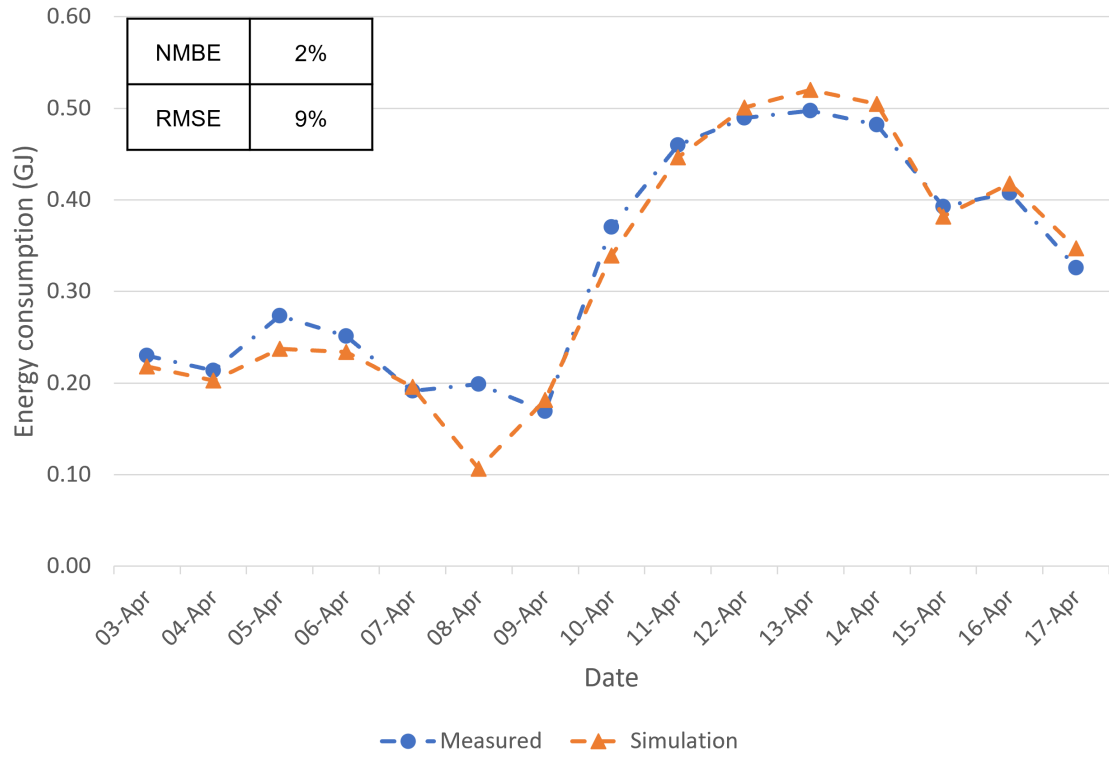
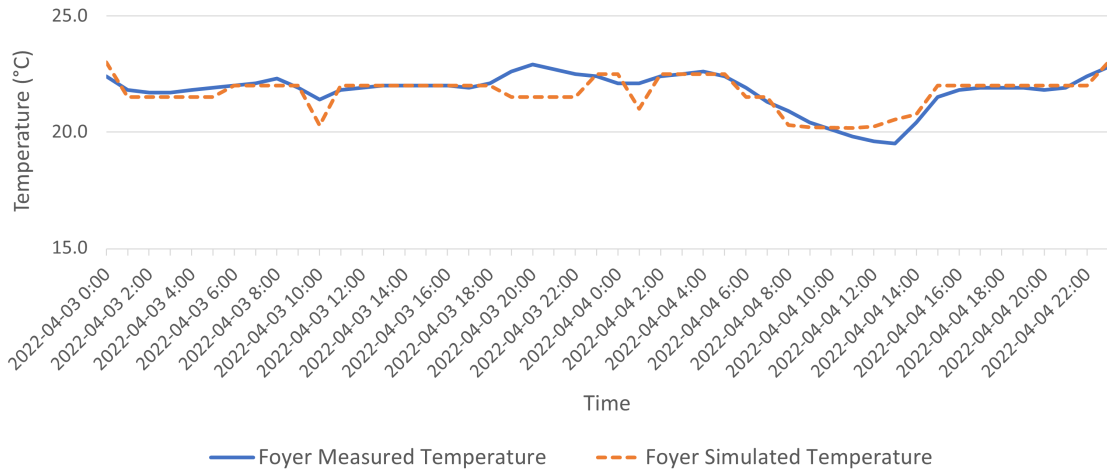

Figure 3.4: Experimental validation of the model for simulating the energy consumption for the space heating system compared to measured data for the data collected from April 3, 2022, to April 17, 2022.

3.3.2 Rooms' temperatures

In this study, not all the rooms and zones in the house are equipped with temperature sensors. To be able to use room temperature obtained from the energy model for the rest of the study, the simulated temperature from different rooms needs to be validated with the measured temperatures. For this purpose, the temperature of four zones in the building including; the foyer, living room, master bedroom, and office, were collected between April 3rd, 2022 to April 4th, 2022, using the sensors that were installed in those areas and were compared with the simulated temperatures from the energy model. Figures 3.5 and 3.6 illustrate the measured temperatures and simulated temperatures between April 3rd, 2022, to April 4th, 2022 for all four areas. The difference between the sensor data and the simulated temperature could be the result of different parameters including capturing solar energy in the building in the model, the number and activity of the occupants in the room, the accuracy of the sensors, and outside conditions obtained from the weather station and the actual condition of the testbed.



(a) Foyer

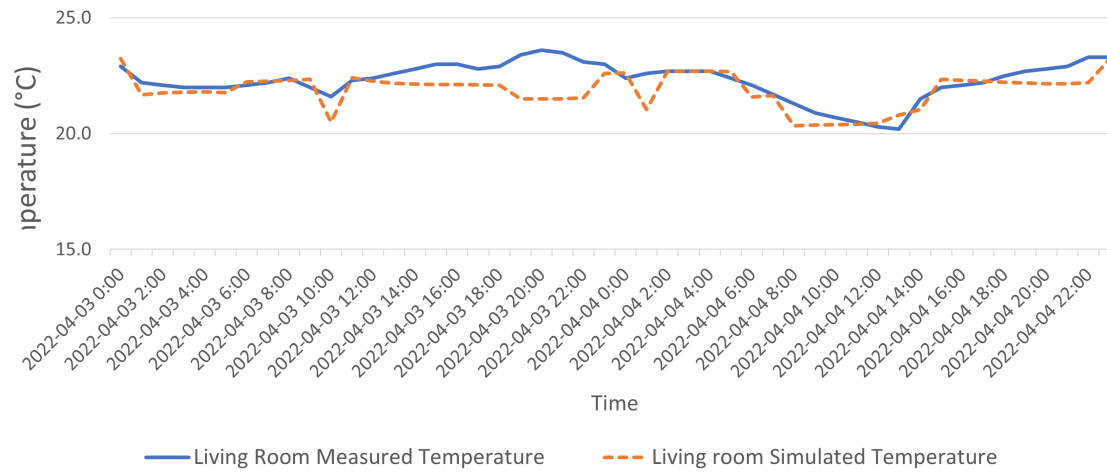

(b) Living room

Figure 3.5: Measured temperature against simulated temperature for the foyer, and living room between April 3rd to April 4th, 2022.

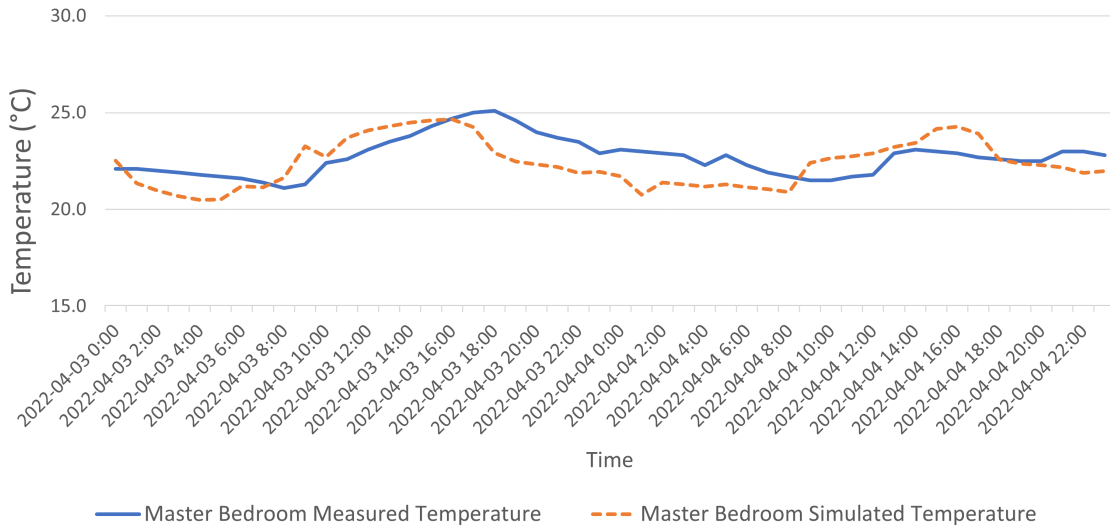

(a) Master bedroom

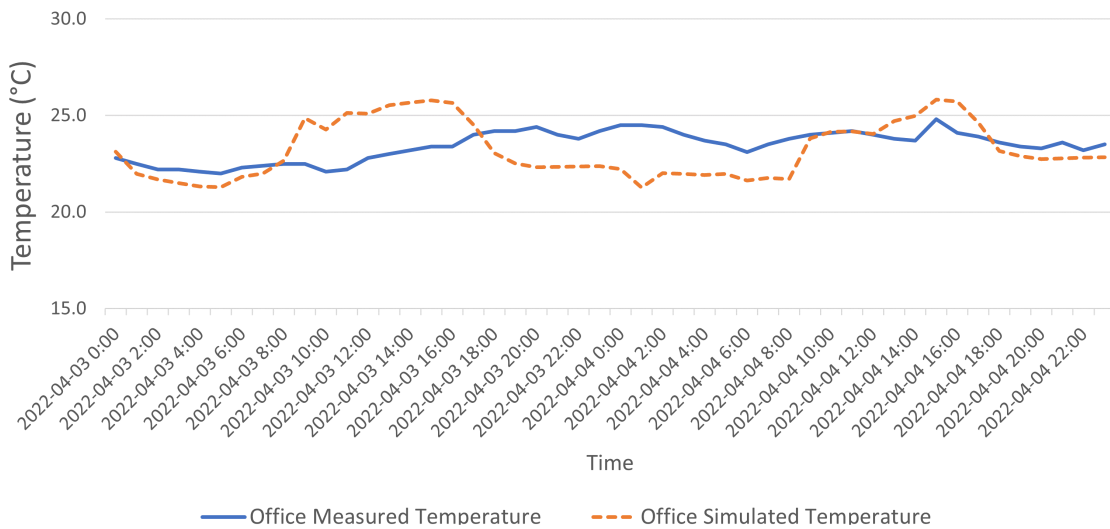

(b) Office

Figure 3.6: Measured temperature against simulated temperature for the master bedroom, and office between April 3rd to April 4th, 2022.

The model validation results are presented in Table 3.5. The validation results show that the temperatures from the energy model for the rooms in the building can be used with good accuracy without the need to install many temperature sensors in the building.

Table 3.5: The validation results for room temperatures.

	2 days validation with 1 minute time interval	
	NMBE (%)	RMSE (%)
Foyer	0.3	3.1
Office	0.9	6.4
Master bedroom	1.5	6.3
Living room	1.8	3.6

Chapter 4

Machine learning based occupancy detection

4.1 Occupancy detection using environmental data

As discussed in Chapter 1, sensor fusion is one of the methods that have been used to detect or predict the state of occupancy in buildings without creating any privacy issues. For this study, four different classifiers that reported high accuracy for occupancy prediction in the literature [8, 26, 29, 30, 53, 87] were used to predict the state of occupancy in the office (Figure 2.3b and 2.7b) using CO₂ concentration, room temperature, room relative humidity, and day of the week. These classifiers include:

1. K-nearest neighbors (KNN)
2. Artificial neural network (ANN)
3. Support vector machine (SVM)
4. Decision tree (DT)

Figure 4.1 depicts the inputs and output of these classifiers.

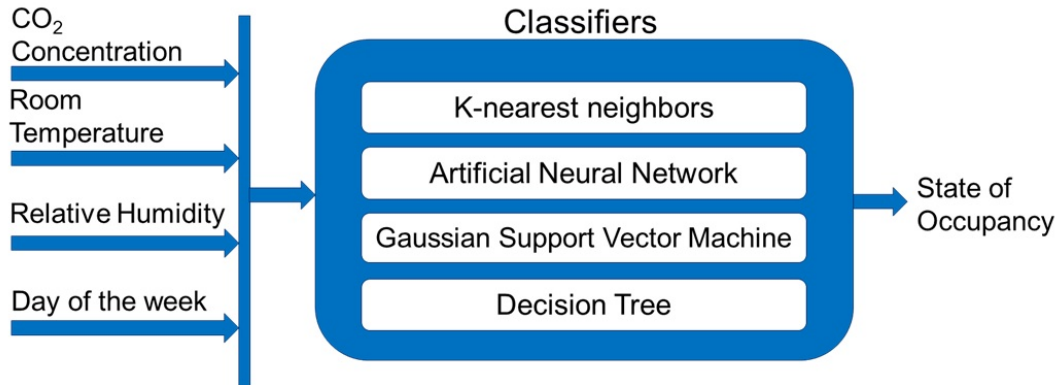

Figure 4.1: Structure of the classifiers and inputs and output of the model

Temperature and relative humidity sensors are affordable to install in different residential building zones to record the data to train the occupancy detection models, but CO₂ concentration sensors are expensive. To investigate the possibility of using more affordable sensors for occupancy detection, the performance of the classifiers has been calculated with and without CO₂ concentration data.

Here each of the four classifiers and their design parameters is explained.

4.1.1 KNN

KNN finds the k nearest training points based on a selected distance metric to classify the test point according to the label of most of those k points [88]. Figure 4.2 demonstrates the KNN method for an algorithm with four neighbors.

To determine the nearest neighbors different distance measures can be used. The



Figure 4.2: KNN schematic for 4-nearest neighbors. The algorithm labels the test data based on the labels for the 4 nearest neighbors.

most common one is the Euclidean distance which can be calculated as

$$d = \sqrt{\sum_{i=1}^k (x_i - y_i)^2} \quad (4.1)$$

4.1.2 ANN

A neural network consists of three sections: input layer, hidden layers, and output layer. As can be seen in Figure 4.3 It feeds the input layer to the first hidden layer of the network and performs the activation calculation which can be chosen from different functions e.g., sigmoid, ReLU, etc. The output of each layer will be calculated by summing the input and applying the transfer function to it. After calculating the output of the network, the weight of each neuron (θ_{ij}^k) will be modified by using a back-propagation algorithm to minimize the error [89].

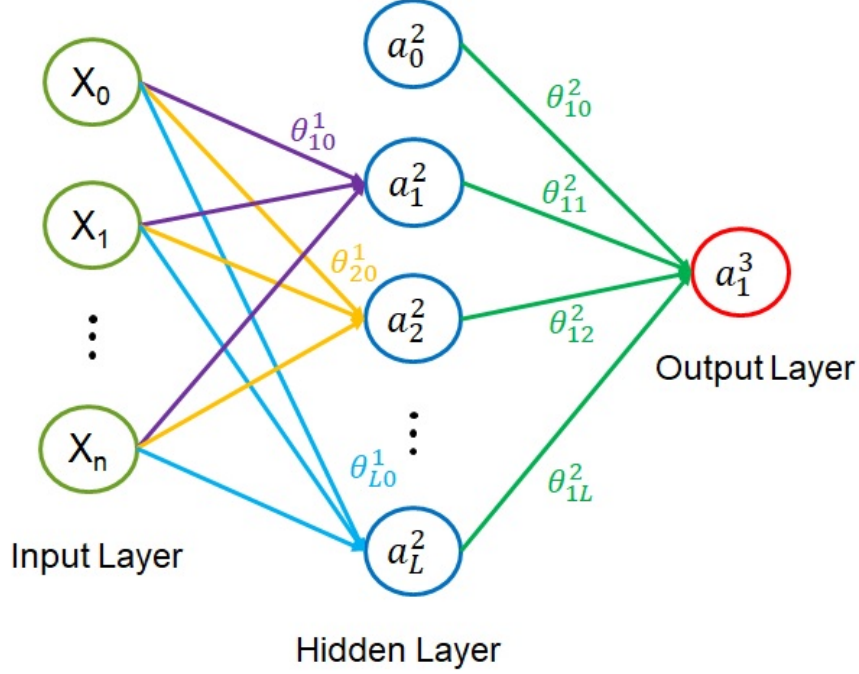

Figure 4.3: Structure of an ANN model.

For an ANN model, the cost function can be defined as [90]

$$J(\theta) = \sum_{i=1}^m (h_{\theta}(x_i) - y_i)^2 + \frac{\lambda}{2} \sum_{k=1}^{K-1} \sum_{i=1}^{S_k} \sum_{j=1}^{S_{k+1}} (\theta_{j,i}^{(k)})^2 \quad (4.2)$$

Where K is the summation of the input, output, and hidden layers, S_k is the number of neurons in the k^{th} layer, and m is the size of the training set.

4.1.3 SVM

The Support Vector Machine is one of the supervised classifiers that solve a convex quadratic programming problem [90]. SVM classifiers label the data by forming hyperplanes to separate the data and then try to maximize the margin between the hyperplane and the data to increase the confidence of classification [91].

Ng [92] shows that for a linear classifier with a two labels classification including $y \in \{-1, 1\}$, the hyperplane with parameters w and b that separates the dataset can be presented as

$$h_{w,b}(x) = g(w^T x + b) \quad (4.3)$$

$g(z) = 1$, if $z \geq 0$ and $g(z) = -1$, if $z \leq 0$. As can be seen in Figure 4.4, the SVM tries to find and maximize d in a way that no training set falls into the area between two dashed lines to increase the confidence in our regression. This can be written as

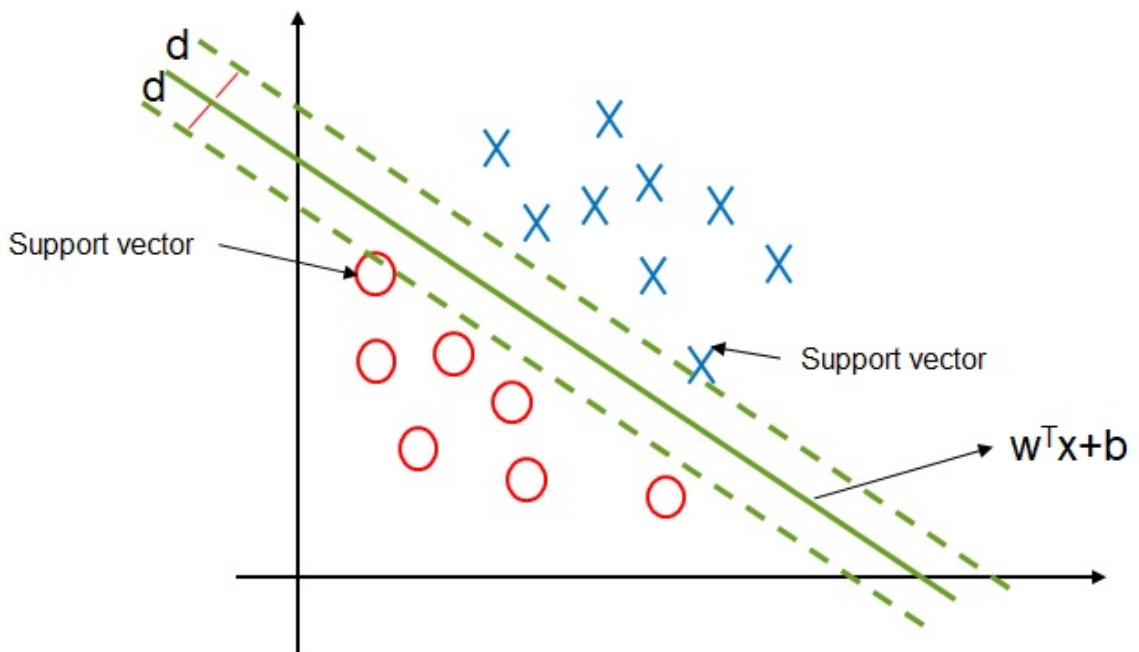

Figure 4.4: SVM schematic.

$$\begin{aligned} \min_{w,b} &= \frac{1}{2} \|w\|^2 \\ \text{s.t.} & \quad y^i (w^T x^i + b) \geq 1, \quad i = 1, \dots, m \end{aligned} \quad (4.4)$$

Using the Lagrangian method to solve the optimization in Equation(4.4), the decision

boundary can be calculated as

$$w^T x + b = \sum_{i=1}^m \alpha_i y^{(i)} \langle x^i, x \rangle + b \quad (4.5)$$

Where, α_i is the Lagrange multiplier and $\langle x^i, x \rangle$ is the inner product of x^i and x .

To find the Lagrange multipliers, a dual optimization problem can be written as

$$\begin{aligned} \max_{\alpha} \quad W(\alpha) &= \sum_{i=1}^m \alpha_i - \frac{1}{2} \sum_{i,j=1}^m y_i y_j \alpha_i \alpha_j x_i^T x_j \\ \text{s.t.} \quad &0 \leq \alpha_i \leq C, \quad i = 1, \dots, m \\ &\sum_{i=1}^m \alpha_i y_i = 0 \end{aligned} \quad (4.6)$$

4.1.4 DT

The decision tree is a classification algorithm that can be used for both discrete and continuous variables. The main terminologies in DT including

- Nodes: each node in DT algorithm could be a root node, internal node and leaf node (Figure 4.5)
- Branches: Each branch is a path from the root node/internal node to another internal node or leaf node
- Splitting: Input variables that are related to the target variables can be used to divide parent nodes (root node/internal node) into child nodes (internal node/leaf node).

- Stopping: Set of rules that protect the model to become complex.

Some of these definitions are shown in Figure 4.5. The DT algorithm splits parent nodes into child nodes by using the input variables till getting into the terminal nodes (leaf nodes) or reaches the stopping rule [93].

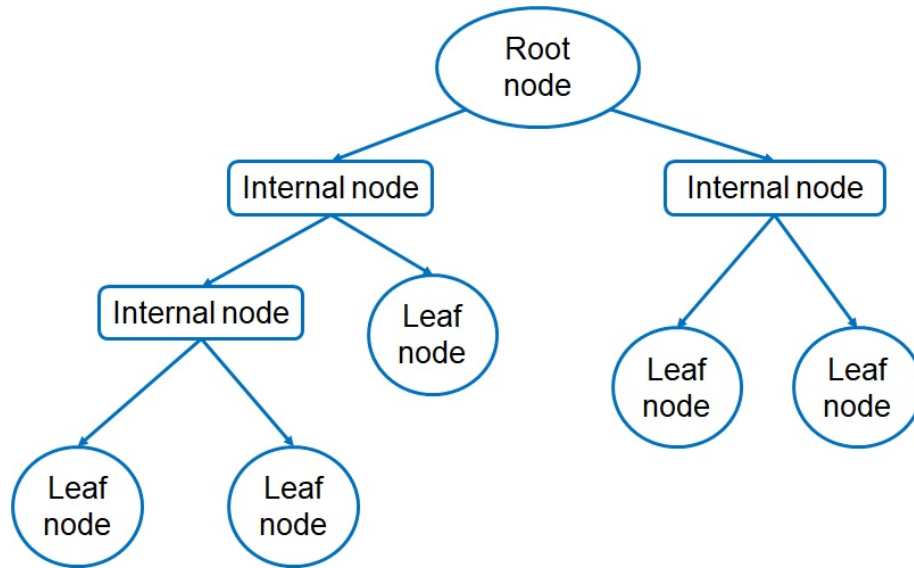

Figure 4.5: DT schematic.

The design parameters for the four classifiers used in this study are shown in Table 4.1.

Table 4.1: Design parameters of the four classifiers used in this study.

Machine learning algorithm	Design parameters
K-Nearest Neighbors	Weighted KNN with 10 neighbors Distance metric: Euclidean Distance weight: Squared inverse
Artificial Neural Network	2 layers First layer size: 15 Second layer size: 15 Activation: ReLU Iteration limit: 1000 Lambda: 0
Gaussian Support Vector Machine	Kernel function: Gaussian Box constraint level: 1 Multiclass method: One-vs-One
Decision Tree	Maximum number of splits: 20 Split criterion: Gini's diversity index

4.2 Model performance

Accuracy is the most common metric that has been used to measure the performance of a classifier. The accuracy is calculated using Equation(4.7).

$$Acc = \frac{TP + TN}{TP + TN + FP + FN} \quad (4.7)$$

Where,

- TP (True Positive) is the number of samples that are classified as positive while the actual sample is positive.
- TN (True Negative) is the number of samples that are classified as negative while the actual sample is negative.
- FP (False Positive) is the number of samples that are classified as positive while the actual sample is negative.
- FN (False Negative) is the number of samples that are classified as negative while the actual sample is positive.

In the case of imbalanced data, accuracy can be highly affected by the dominant class [94]. In this situation, Geometric Mean (GM), is used instead of accuracy to measure the performance of the classifier. The geometric mean is the average of a set

of parameters calculated by the product of their values instead of their summation. In general, it will be equal to the n^{th} root product of n values. For two groups with a dominant group, GM considers the performance of both major and minor groups; thus, it won't overfit or underfit the imbalance classes [94]. GM can be calculated using Equation(4.8).

$$GM = \sqrt{\frac{TP}{TP + FN} \cdot \frac{TN}{TN + FP}} \quad (4.8)$$

As the state of occupancy in the room is not balanced, with 23% occupied and 77% unoccupied, to avoid showing false high performance for the classifiers by just labeling the test data as unoccupied, GM is used in this study to compare the performance of different classifiers. MATLAB Classification Learner Toolbox was used to train and test all four algorithms.

Data collected from March 4th to April 3rd, 2022, were used to train the models. Five features including room temperature, relative humidity, CO₂ concentration, day of the week, and state of occupancy were recorded from the sensors every minute for 31 days. In total 44640 sample data were collected during this period. 70% of the data were randomly selected to train and validate the model and the rest of the data was used to test the models. In addition, five-fold cross-validation was implemented for training and validation of the model to avoid any overfitting. In this method, one

fold is selected and removed from training set, the rest of the folds are used to train the model, and then the removed fold is used to validate the results [90]. A sign of overfitting in a model is that the algorithm performs well on the training set, but when fed with new data (test set) its performance drops significantly [95]. Figure 4.6 compares the training and test performance for four models used in this study. The similar GM for training and test set shows the five-fold cross-validation is effective for avoiding overfitting in all four algorithms.

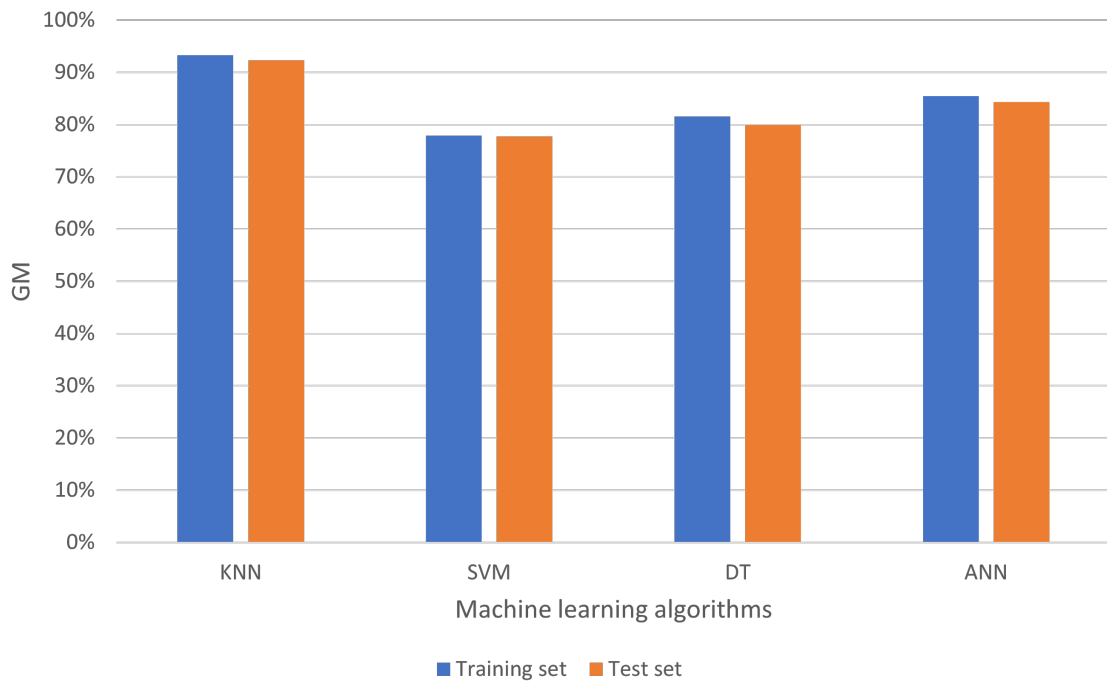

Figure 4.6: Geometric Mean from training set and test set for four algorithms

To find the true state of occupancy in the room, one of the Monnit motion sensors was installed in the room and data collected by this sensor were cross-checked by the log sheets filled in by the occupants. The confusion matrix for all four al-

gorithms while using four features including room temperature, relative humidity, CO₂ concentration, and day of the week for predicting the occupancy can be seen in Figure 4.7. The confusion matrix summarizes the class prediction as a matrix and presents how many correct and incorrect predictions are made by the model [96]. For each confusion matrix, classes 1 and 0 represent occupied and unoccupied states respectively. In these confusion matrices, the occupied prediction while the room was actually occupied shows the "True Positive", and the occupied prediction while the room was unoccupied represents the "False Positive". On the other side, states that predicted unoccupied when the room was unoccupied show the "True Negative" and finally, any predictions as unoccupied while the room was occupied form the "False Negative". These values can be used to calculate the GM for each classifier based on Equation (4.8). The comparison between the GMs of four classifiers is presented in Figure 4.6.

Both GM and confusion matrix show that the KNN model provides the best performance by predicting the occupancy with a geometric mean of 92% and after that ANN, DT, and SVM models predicted the state of occupancy by GM equal to 84%, 80%, and 78% respectively. Another parameter that can be considered to compare the performance of classifiers and the possibility of their real-time application is the training time. This metric is presented in Table 4.2. Although DT and KNN can train

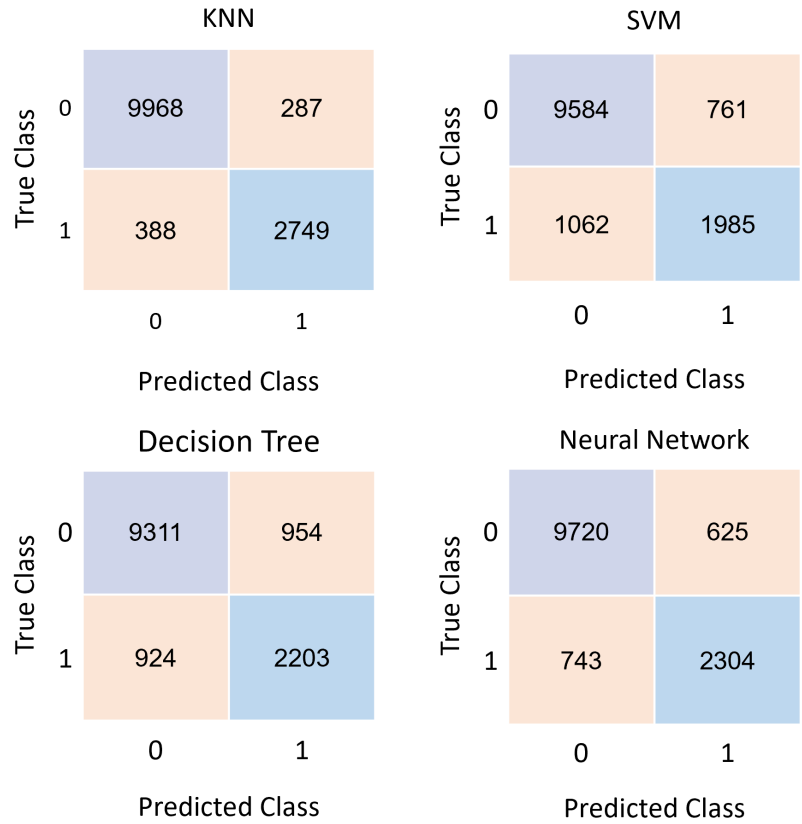

Figure 4.7: Confusion matrices for occupancy detection test using different ML algorithms with four predictor features (i.e., Temperature, CO₂ concentration, RH, and Day of the week).

the model in less than a minute, considering using common 10-minute time intervals in building control systems makes SVM and ANN feasible algorithms for real-time application as well.

Table 4.2: Training time for four classifiers.

Classifier	Training time (second)
KNN	3.5
SVM	72.7
DT	1.98
ANN	126.17

If all four features are used for the occupancy prediction, all algorithms provide high-quality occupancy data which can be used by the building control system to optimize energy consumption. As CO₂ exists in human exhalation, it is a good indicator of human presence in an area in a residential building, but unfortunately, CO₂ sensors are expensive (i.e. Monnit Wireless Carbon Dioxide (CO₂) Sensor costs \$396 [97]) and may not be available in every residential building. To investigate the possibility of using the most available data in residential buildings such as room temperature and relative humidity, all the algorithms were trained and tested using all features except CO₂ concentration. Figure 4.8 depicts the performance of different algorithms while removing CO₂ concentration data. Despite the decrease in the accuracy of the models after removing CO₂ as one of the features, the KNN method can predict the state of occupancy in the room with acceptable accuracy by having the room temperature, relative humidity, and day of the week with GM equal to 81%.

These results show although using CO₂ sensor where it is possible can increase the accuracy of the occupancy prediction, the ML models can still predict the occupancy status with reasonable accuracy with having basic environmental data such as temperature and relative humidity along with other available data such as day of the week.

Another parameter that is important in occupancy prediction is the number of

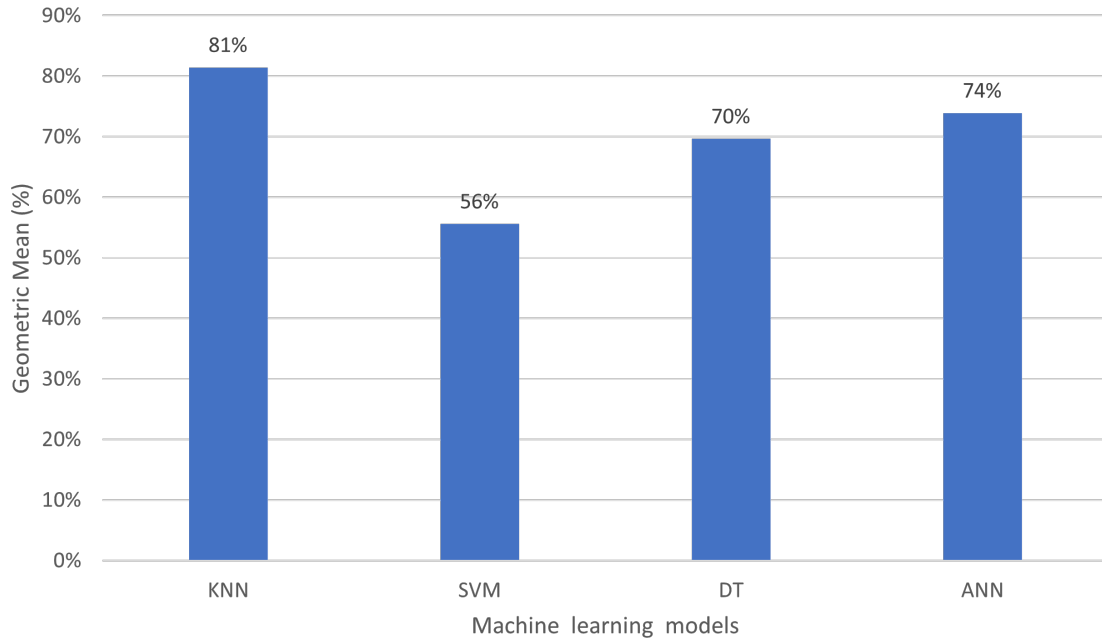

Figure 4.8: Geometric Mean, while CO₂ concentration has been removed from predictor features.

samples that are required for an accurate occupancy prediction. A model can be trained by the data collected from the sensors for one day or one week or one month. Thus, the effect of the amount of required data on the accuracy of the model needs to be investigated. To this end, all four models are trained with different amounts of training data that vary from one day of collected sensor data to 30 days of collected sensor data by incremental change of one day. The GMs for all the models are presented in Figure 4.9. As can be seen, while the sensor data is less than four days, the GMs increase sharply by using more data for training the model; however, this improvement slows down as more data were added for training the models. For all the models adding more than 10 days of sensor data won't improve the performance of the

model significantly and in some cases (e.g. DT) may even reduce the performance.

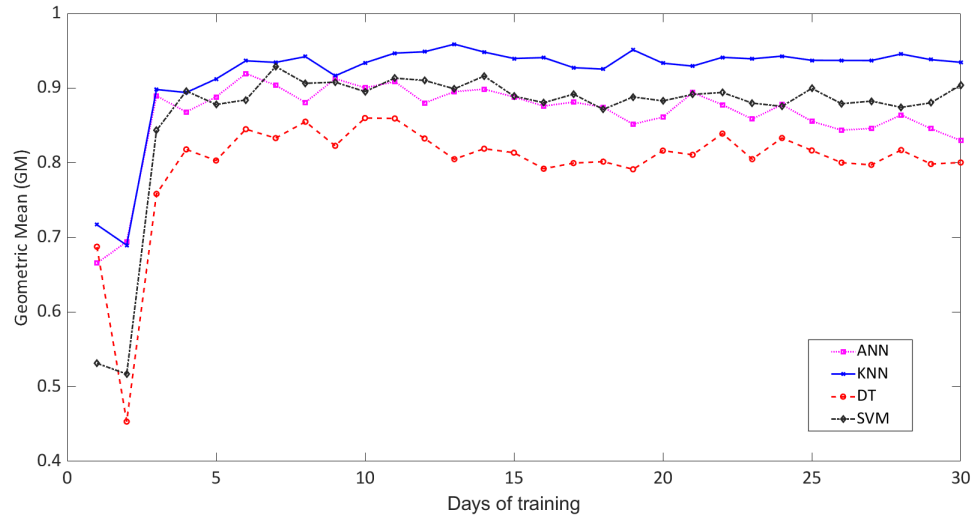

Figure 4.9: Effect of training data size on the performance of the KNN, ANN, DT, and SVM models to predict the room occupancy status.

Another parameter that can affect the performance of the classifiers is the gap between the date that data were collected to train the model and the date that occupancy needs to be predicted. To study the effect of having a gap between the data used for training the model and the data used for making the prediction, the KNN, ANN, SVM, and DT models were used to predict the state of occupancy for four different weeks (The design parameters and the difference between these algorithms are described in Section 4.1). Only two days of data from April 3rd to April 4th were used to train the models. The models' performance is presented in Figure 4.10. As can be seen in the figure, the GM of a model that has been trained by the data obtained a month ago drops dramatically. This can be explained as occupancy in residential

buildings changes during the year. The outside activity during Spring and Summer could be different from activities during Fall and Winter, and these changes in the occupant behavior should be captured by the models; otherwise, a model that has been trained based on the data collected during Winter, cannot predict the occupancy in Summer accurately.

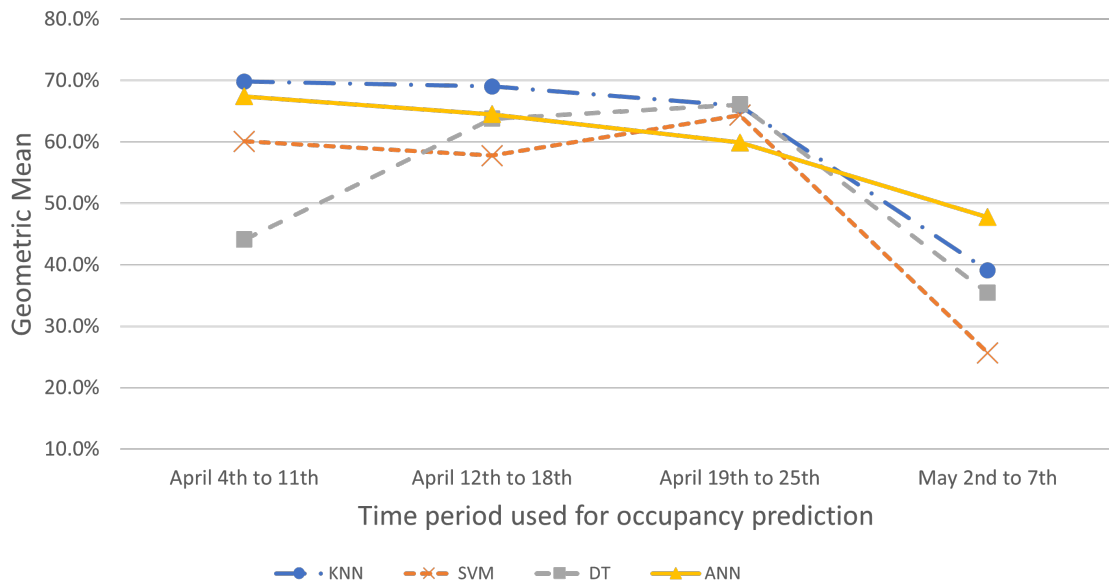

Figure 4.10: The performance of models trained using data collected between March 3rd and April 4th for predicting occupancy for the seen data ranging from April 4th to May 7th.

To make sure a model performs accurately during the year, the times that can change the occupant behavior should be identified and the model should be trained again with the data collected close to those occasions. In addition, one needs to include those identifiers as input features in Figure 4.1 that was discussed previously.

Chapter 5

Energy use optimization and control strategies

In Chapter 4 different machine learning algorithms were used to define the state of occupancy in the building via sensor fusion. In this chapter, the effect of using occupancy information in control of the building's heating system for reducing energy consumption in the building is discussed. To be able to apply the sensor fusion method to capture occupancy information in every zone in the building many other sensors needed to be added to the building. But, this could increase the cost significantly. To decrease the cost in this study and increase the accuracy of the occupancy information, the occupancy information was collected using PIR sensors and log sheets filled by the occupants in the building.

5.1 Energy consumption and occupants comfort level

Based on the ASHRAE 55 [9], desired occupied space's temperature varies from 19.5 °C to 27 °C and can be different from one person to another person. The ultimate goal of a space heating control system is to minimize energy consumption while maintaining occupants' comfort levels. To achieve this goal, programmable thermostats and smart thermostats with WiFi connection have been introduced to the market (e.g., see Ecobee smart thermostat premium, and Google Nest learning thermostat). In some cases, these thermostats are also equipped with motion detection sensors to observe the occupancy in the area they have been installed for (such as the NEST thermostat E that is installed in the testbed). However, occupancy detection is limited to the area where the thermostats are installed and sometimes it can affect the comfort level of the occupants in the other parts of the building (e.g., the heating system could be turned off as no occupancy is detected by the thermostat while the occupants are in different part of the building).

Despite an increase in using programmable thermostats for space heating applications in residential buildings that can reduce heating energy consumption, a large portion of households still use manual thermostats or do not have any thermostats (Figure 5.1). Furthermore, among all the households that use heating equipment,

with any type of thermostat, more than 43% of them choose a temperature and don't change it most of the time (Figure 5.2).

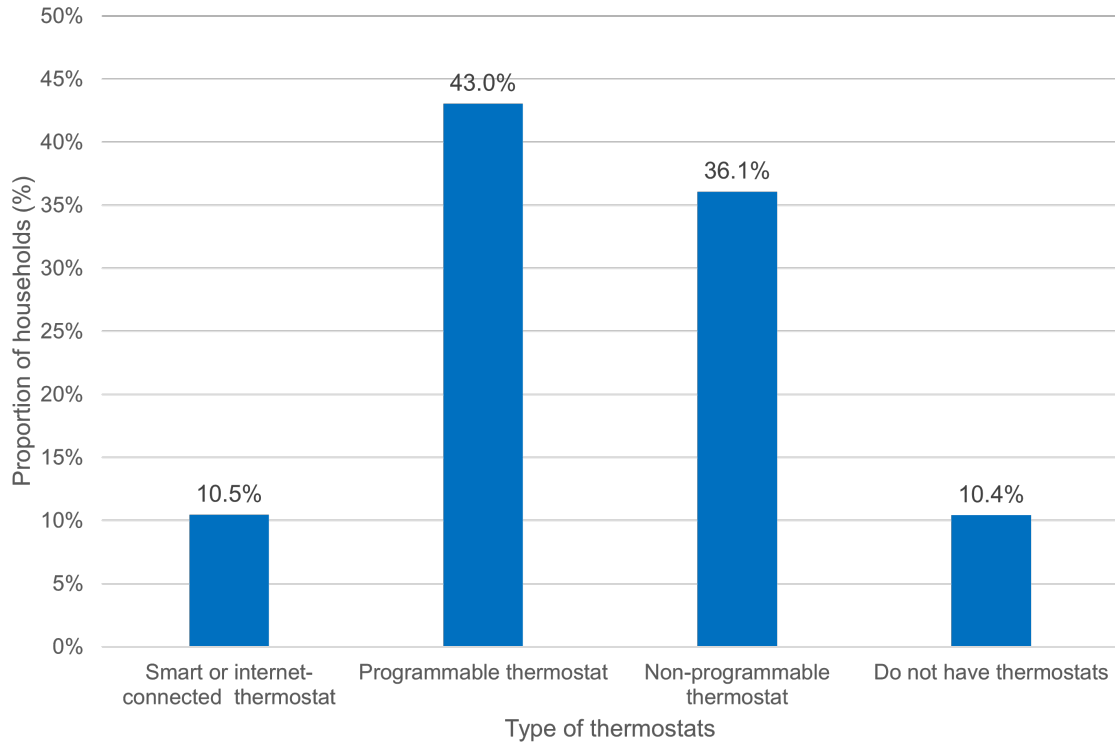

Figure 5.1: The proportion of the households in the US that use a certain type of thermostat for space heating [98].

In addition, 51% of Canadian households use forced air furnaces to warm up their houses in 2021 [18], and in most cases, there is only one thermostat that controls the heating system. The thermostat is normally installed in the entrance or living room and the occupants turn the heating system on and off by adjusting the desired temperature in that area. While the temperature in the area the thermostat has been installed could be within the comfort level of the occupants other parts of the house can experience different temperatures.

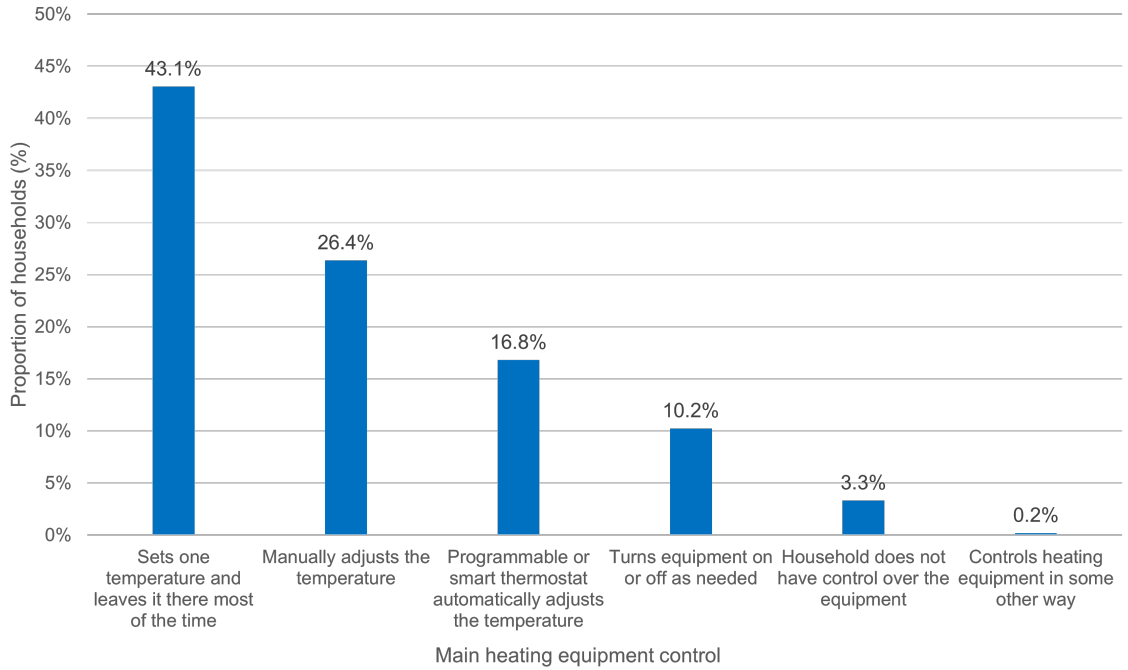

Figure 5.2: Main heating equipment control used in the US households [98].

Figure 5.3 shows the difference between the temperature in different areas of the testbed and the desired temperature that has been set for the thermostat which is located in the foyer (entrance) between 11:00 a.m. and 4:30 p.m. on March 31st, 2022. During this time only the second floor (either the Master bedroom or office) was occupied. As can be seen in Figure 5.3 while the temperature sensor in the entrance records almost the same temperature as the thermostat temperature, the sensors in the office and master bedroom show up to 3.5 °C difference with the thermostat set temperature. In this case, the occupants' comfort level and energy saving can be improved by using an occupancy-based control system and a proper means to adjust the temperature in different rooms in the building.

On the other side, in some situations, occupants' comfort level and energy saving are not aligned together. Figure 5.4 illustrates one of these situations. It shows the temperature recorded by sensors in the foyer (entrance) and the master bedroom and the set temperature for the thermostat. Similar to the previous case, the occupied area (master bedroom) has a larger temperature deviation from the set temperature of the thermostat that is installed in the entrance (2.5 °C), but in this case, to improve the comfort level of the occupants more energy needs to be used.

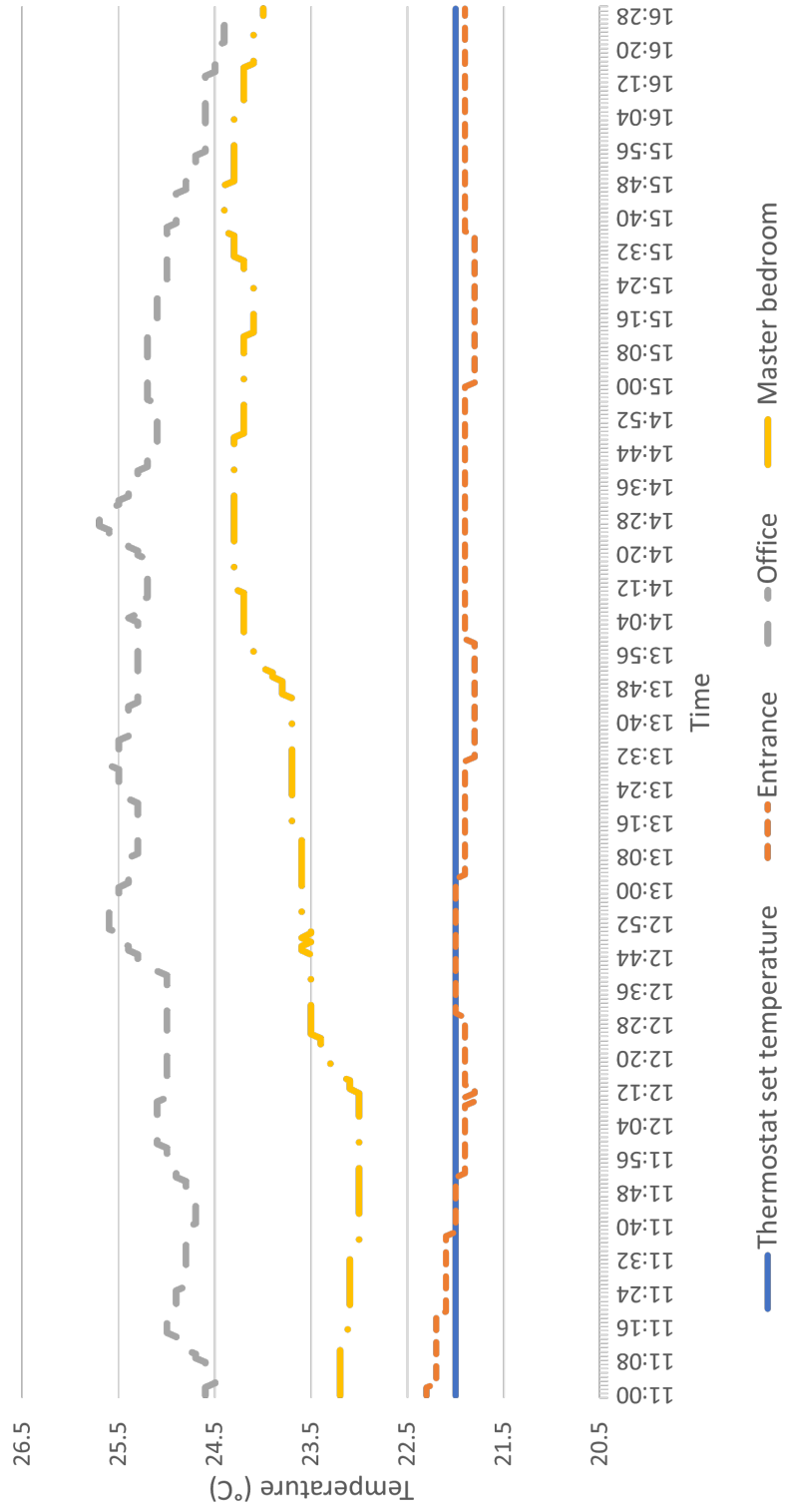

Figure 5.3: Comparison of the thermostat temperature and the temperature recorded by sensors in the entrance (foyer), master bedroom, and office between 11:00 a.m. and 4:28 p.m. on March 31, 2022.

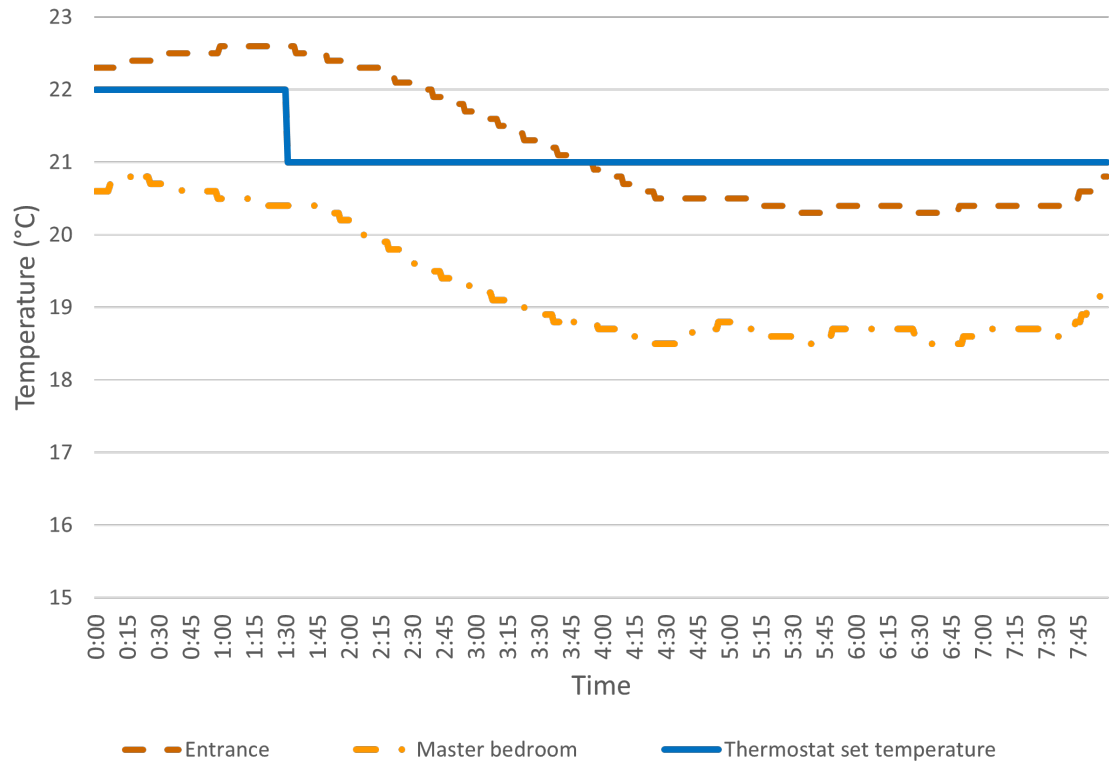

Figure 5.4: Comparison of the thermostat set temperature and the temperature recorded by sensors in the entrance (foyer) and the master bedroom between 00:00 a.m. and 7:56 a.m. on Nov 7, 2021.

5.2 Different Control Approaches

After validating the energy model, the occupancy information of the building for four weeks between March 21, 2022, and April 17, 2022, was added to the energy model described in Chapter 3. To be able to compare different control scenarios a baseline is defined by assuming that occupants set the thermostat at a specific temperature and won't change the set temperature from time to time. Without considering saving energy as a priority, the occupants preferred 23°C as their desired temperature so this temperature was considered the set temperature for the thermostat. In this section, the energy saving for five different control approaches will be compared with this baseline.

5.2.1 Central heating system, ruled-based control system with building occupancy data

In this part, the entire building is equipped with a “central heating system” and three different approaches are defined as follows, and the energy consumption in the building is determined for each case by the validated energy model.

- Case 1: Occupancy-based model with the fixed set temperature at 23°C during the occupancy and 13.5 °C while the house is not occupied. In this case, the set temperature is applied to the whole building.

- Case 2: User-defined set temperature that has been set by the occupants through Google NEST thermostat. In this case, occupants were asked to adjust the NEST thermostat set temperature to lower than 23°C when possible to save energy.
- Case 3: Occupancy-based model that follows a user-defined set temperature explained in case 2 during the occupancy period and uses the set temperature of 13.5 °C when the house is not occupied based on the actual occupancy information collected from PIR sensors and time sheets filled by the occupants. Case 3 is the combination of Case 1 and Case 2, i.e., whenever the house is occupied follows Case 2's thermostat set temperature and applies Case 1's thermostat set temperature whenever the house is unoccupied.

For all three cases described above, the thermostat set temperature is based on the foyer's temperature and controls the heating system for the entire building.

The thermostat set temperatures for Case 1 and Case 2 are shown in Figure 5.5. The temperature of 23°C was considered as the set temperature for Case 1 as it is the preferred temperature for the occupants. Also, 13.5 °C was maintained as the set temperature when the building was not occupied in Cases 1 and 3 to avoid any damage to the building pipeline in winter [9, 13]. Case 2 simulates the energy consumption

when occupants were asked to adjust the set temperature manually using the Google NEST thermostat and its mobile App to save energy by using the lower temperature when they are away or compromising their comfort level for energy saving whenever possible. In addition, the NEST thermostat used its motion sensor and decrease the set temperature to 13.5 °C when detected no occupancy in its surrounding area.

To clarify the difference between Case 1 and Case 2, the temperature schedule that was defined by the occupants for April 16, 2022 (Case 2), is compared with the set temperature in Case 1 in Figure 5.6 (This is a zoomed-in view of Figure 5.5).

Case 3 follows the set temperature defined by the occupants in Case 2 while dropping the set temperature to 13.5 °C when the building was not occupied according to the actual building occupancy information collected by Monnit PIR sensors and time sheets filled by the occupants.

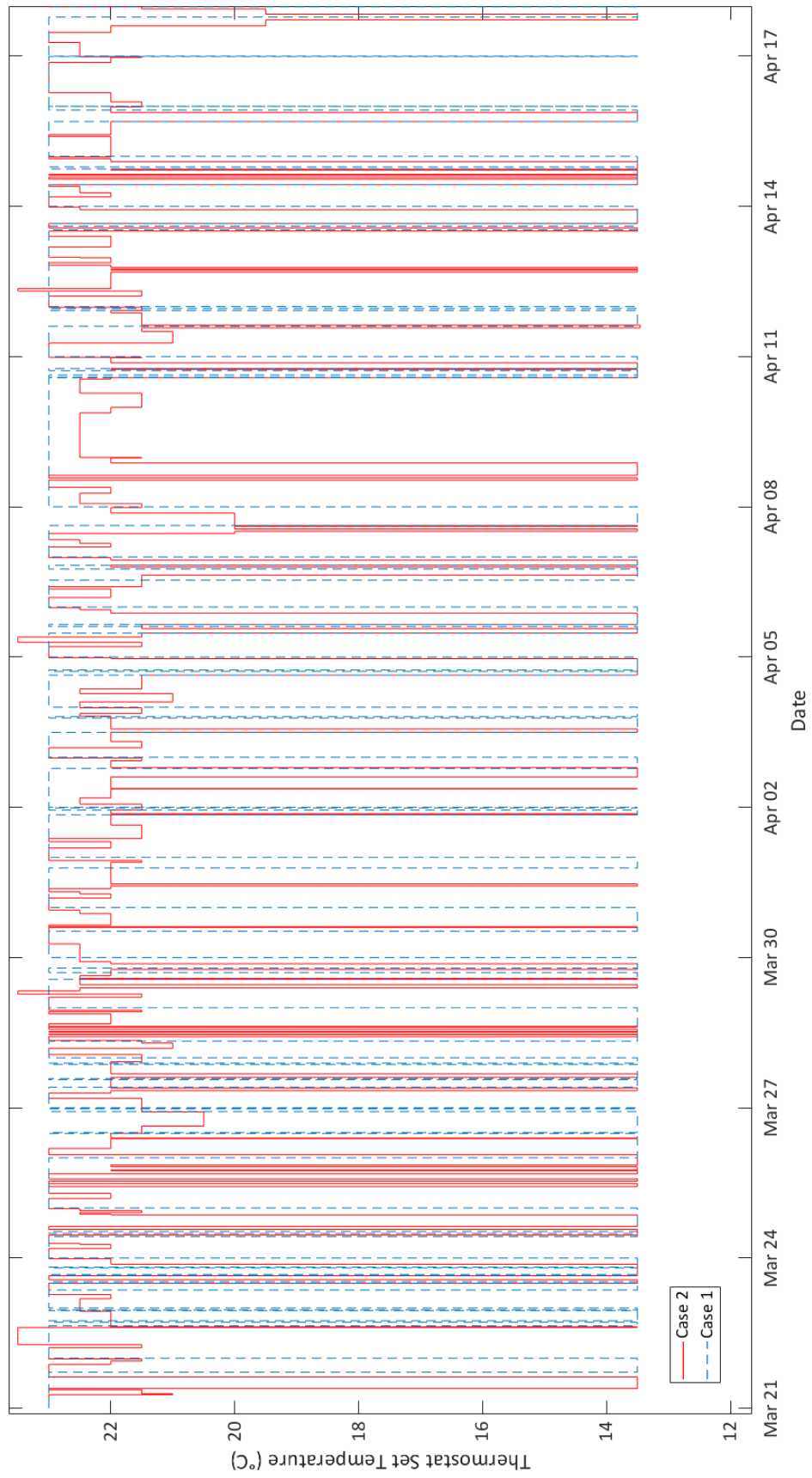

Figure 5.5: Case 1 and Case 2 thermostat set temperatures between March 21, 2022, and April 17, 2022.

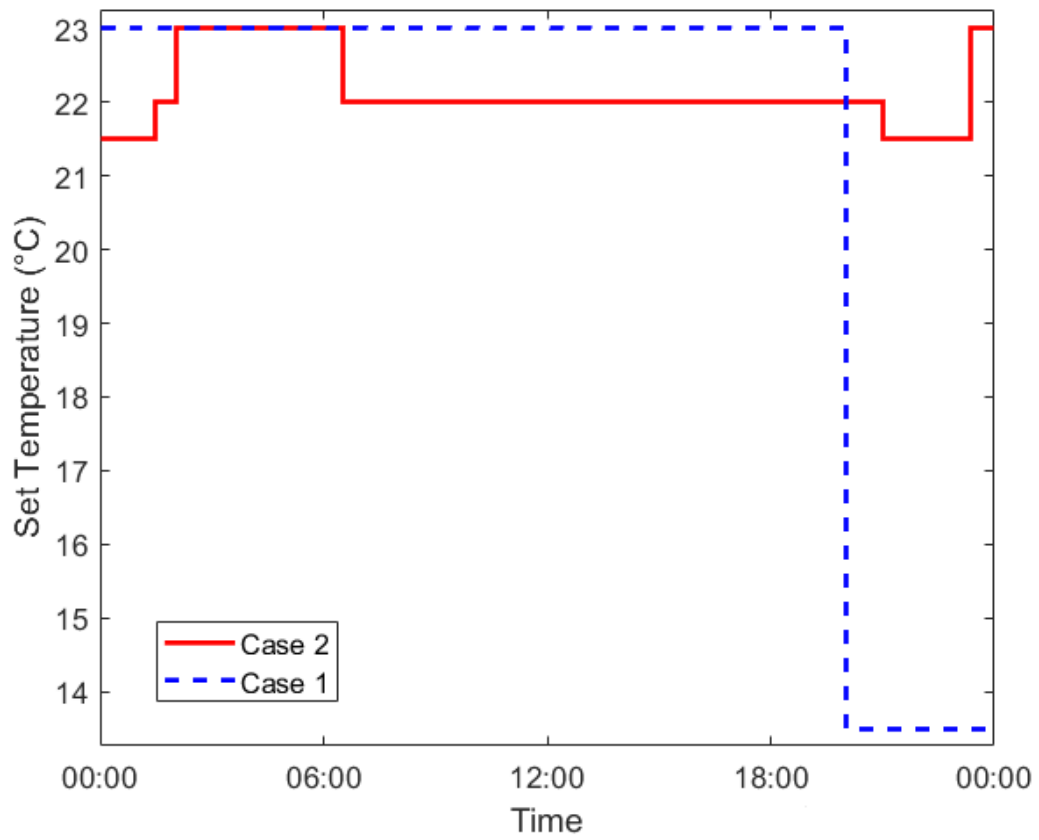

Figure 5.6: Set temperature for Case 1 and Case 2 on April 16, 2022. This is a zoomed-in view of a day of data from Figure 5.5

Daily energy consumption for the baseline and three cases is illustrated in Figure 5.7. In addition, Table 5 presents the total energy consumption during the test period and energy saving for all three cases compared to the baseline. It shows using occupancy information in the heating control system can save up to 18.2% in energy consumption of the building. The percentage of energy saving for Cases 1 and 2 shows that using occupancy information with a simple occupancy-based control system that maintains the building temperature at the desired temperature of its occupants in Case 1, provides more energy-saving opportunities compared with Case 2 where occupants compromise their comfort level by lowering the set temperature to save energy. In addition, comparing the energy saving of Case 1 and Case 2 with Case 3 shows that occupants mostly were adjusting the thermostat set temperature while they were inside the building rather than lowering the set temperature while they were away.

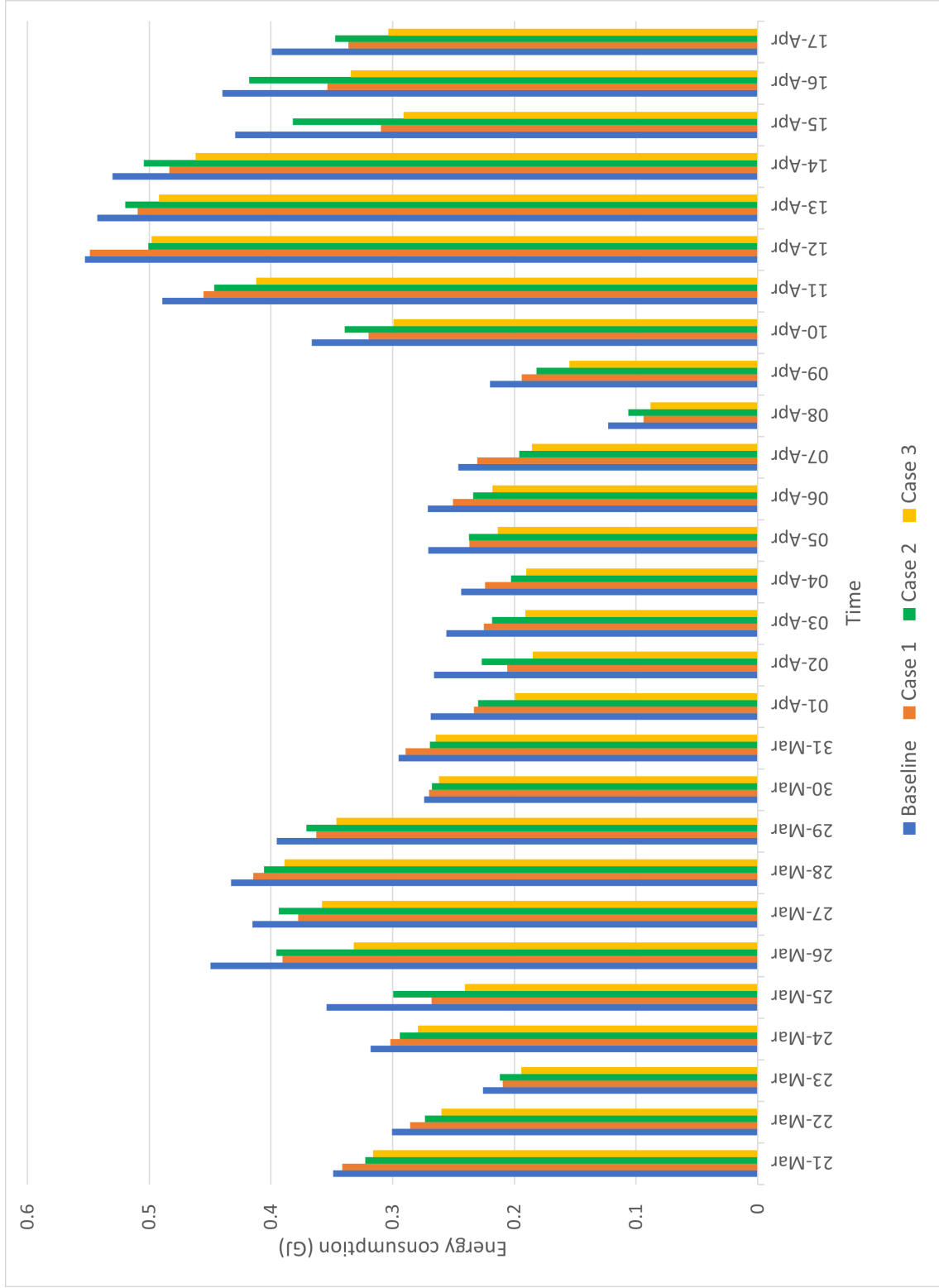

Figure 5.7: Daily energy consumption for the baseline, case 1, case 2, and case 3 between March 21, 2022, and April 17, 2022.

Table 5.1: Energy consumption and energy saving for the baseline, case 1, case 2, and case 3. All values have been calculated for four weeks between March 21, 2022, and April 17, 2022.

	Total energy consumption (GJ)	Energy saving (%)
Baseline	9.72	N.A.
Case 1	8.72	10.3
Case 2	8.8	9.5
Case 3	7.95	18.2

5.2.2 Single zone, ruled-based control system with zone occupancy data

As mentioned previously, setting a desired temperature for the thermostat does not necessarily lead to having the desired temperature in the occupied areas (Figures 5.3 and 5.4).

To find a solution and be able to achieve the desired temperature in the occupied area of the building a virtual sensor is developed in this thesis to adjust the thermostat set temperature based on the desired temperature in the occupied rooms. The following steps have been considered in developing the virtual sensor model:

- The state of occupancy is obtained for the office, master bedroom, and living room using Monnit motion sensors and log sheets filled by the occupants (As mentioned at the beginning of this chapter because not all the areas in the building were equipped with a CO₂ sensor the PIR sensors were used to define

the occupancy in the building).

- Three ANN models are trained to predict the thermostat set temperature based on the data including, room temperature, room occupancy, state of the furnace, outside temperature, and the hour of the day for each of the three above-mentioned rooms (Figure 5.8a).
- To specify the thermostat set temperature based on the desired temperature in each room, instead of the room temperature, the desired temperature is fed into the ANN model. By this change, the output of the ANN model will be the desired thermostat set temperature that provides the desired temperature in the office, master bedroom, and living room (Figure 5.8b).
- Based on the occupancy in the office, master bedroom, and living room the adjusted thermostat temperature is selected (while more than one area is occupied the average temperature is selected) and the energy simulation will be performed accordingly to calculate the energy consumption and rooms' temperatures (Figure 5.9).

To study the performance of the proposed virtual model, energy consumption and rooms' temperatures are calculated for April 10, 2022, which is selected randomly, and then the results are compared with the results obtained from the baseline en-

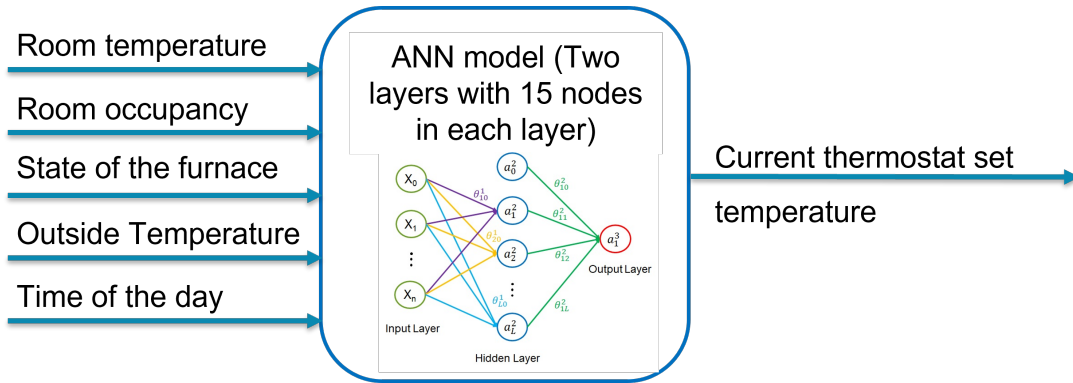

(a) The layout of the ANN model used to predict the thermostat temperature based on the room's data.

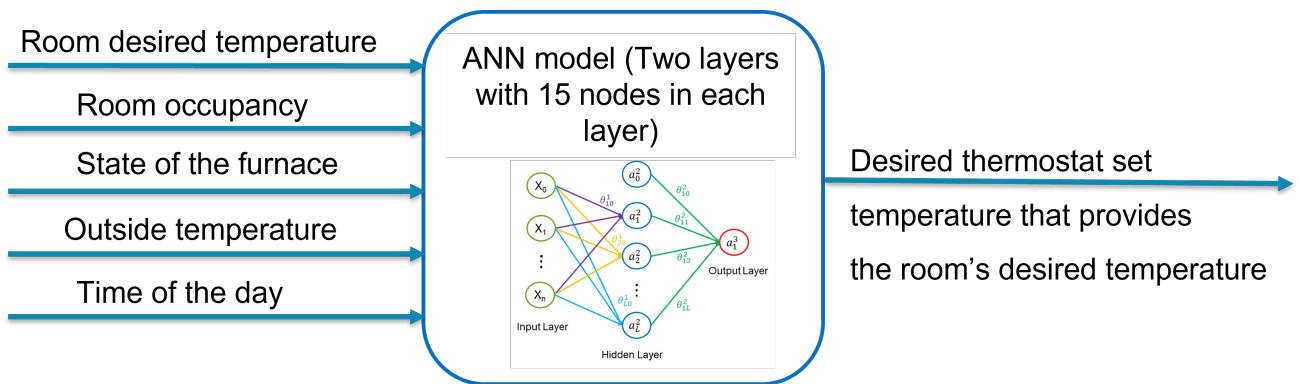

(b) The layout of the ANN model that predicts the thermostat temperature that satisfies the room desired temperature.

Figure 5.8: The ANN model layout used to develop the virtual sensor.

ergy model explained in Section 5.2.1 for the same date. In the baseline model, the thermostat temperature that is installed in the foyer area is set to 23 °C and won't change based on the occupancy. In the virtual sensor model, the desired temperature of 23 °C is considered for the occupied space, and the thermostat temperature that provides the desired temperature in the room is predicted using the ANN model for each room. The final thermostat temperature is defined based on the occupancy of the rooms. In the cases that the building is not occupied the thermostat temperature

is reduced to 13.5 °C.

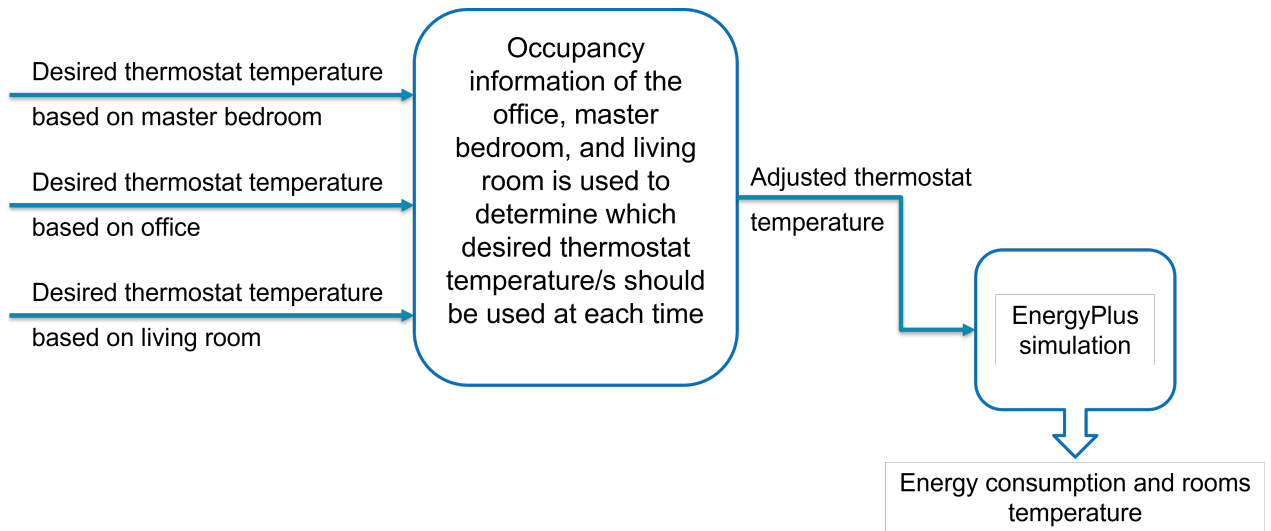

Figure 5.9: The process of energy model simulation for the virtual sensor model.

The data collected between March 21, 2022, and April 9, 2022, are used to train three ANN models for the master bedroom, office, and living room. The accuracy of these models is shown in Table 5.2. Then the above-mentioned steps for the virtual sensor model were followed to obtain the energy consumption and room temperatures. As can be seen in Table 5.3 using the virtual sensor reduced the energy consumption by 15% and improved the comfort level of the occupants by decreasing the deviation from the desired temperature.

Table 5.2: The performance of the ANN models (see Figure 5.8) used to predict the thermostat temperature on April 10, 2022, based on the data collected from the master bedroom, office, and living room between March 21, 2022, and April 9, 2022.

ANN Model	Accuracy of the model (%)
Predict thermostat set temperature based on the Office's temperature	88
Predict thermostat set temperature based on the Master bedroom's temperature	78
Predict thermostat set temperature based on the Living room's temperature	92.5

Table 5.3: Comparison of energy saving and occupant comfort level in the occupied room(s) between baseline model and virtual sensor model for April 10, 2022.

Metric	Baseline	Virtual sensor	Improvement/Saving
Energy consumption	351.30 (MJ)	296.4 (MJ)	15%
Time with a temperature difference of more than 1.5 °C between occupied room temperature and desired temperature (23 °C)	319 min	221 min	30%
Time with a temperature difference of more than 1 °C between occupied room temperature and desired temperature (23 °C)	321 min	299 min	7%

5.2.3 Multi zone control system with zone occupancy data

In this section, the energy efficiency of the central heating system that provides heat for the entire house is compared with using more than one heating system that each provides heating for different thermal zones in the building. The heating capacity of the central furnace has been divided into two units one for the main floor and one for the second floor based on their surface areas. The heating capacity for each unit is presented in Table 5.4. As can be seen in this table, the capacity and the flow rate

are a fraction of the actual heating system installed in the building (Table 2.1), but the temperature rise (the difference between the temperature of the air exiting the furnace and the temperature of the air entering the furnace) is same.

Table 5.4: Heating systems specifications for one unit for the main floor and one unit for the second floor.

Heating unit (main floor)	
Input (kJ/H)	34400
Blower flow rate (m ³ /s)	0.27
Temp.rise (Min.-Max) °C.	16 - 33
Heating unit (second floor)	
Input (kJ/H)	49600
Blower flow rate (m ³ /s)	0.39
Temp.rise (Min.-Max) °C.	16 - 33

The occupancy of each floor between March 21, 2022, and April 17, 2022, is determined using Monnit motion sensors and the log sheets filled by the occupants. 23 °C is considered the desired temperature according to occupants whenever the floor is occupied and the set temperature dropped to 13.5 °C when the floor is not occupied. EnergyPlus was used to calculate the energy consumption. Figure 5.10 compares the daily energy consumption of the model with two heating units, with the baseline and case 1 that are described in 5.2.1.

Table 5.5 shows the energy consumption and possible energy saving for each of the above-mentioned scenarios for the entire period of March 21 to April 17. Using a

separate heating unit for each floor can save more than 30% compared to the baseline and more than 22% when it is measured against the model with one heating system for the entire building that only considers the occupancy in the whole building, not each floor.

Table 5.5: Comparison of the energy consumption and energy saving when using two separated heating units (Table 5.4) for the main floor and second floor.

Energy consumption	Baseline	9.72 (GJ)
	Case 1 (one heating system for the building)	8.72 (GJ)
	Two heating units (One unit for each floor)	6.73 (GJ)
Saving	Compare to the baseline	30.7(%)
	Compare to the Case 1	22.8(%)

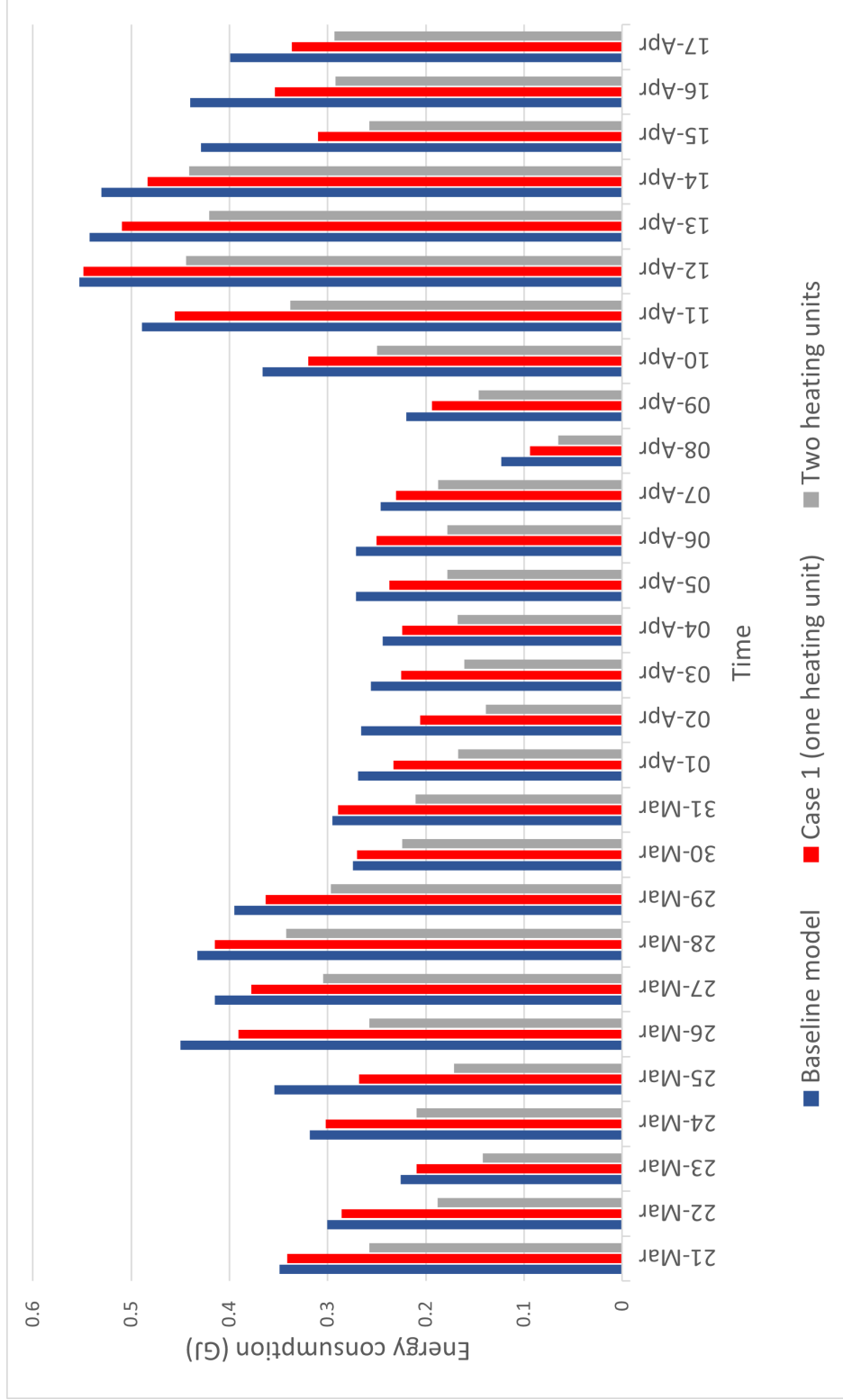

Figure 5.10: Daily energy consumption for the baseline, case 1, and two heating units (Table 5.4) for the period from March 21, 2022, to April 17, 2022.

5.3 Cost saving of different control approaches for energy simulation

Here, the cost saving due to energy saving by using occupancy-based models for the household through the cold season is calculated. To this end, the actual natural gas consumption is retrieved from the utility bills for the testbed. For the one-month period of energy simulation, between March 21st and April 17th the actual energy consumption is equal to 8.29 GJ. In addition, Table 5.6 presents the actual natural gas usage by the heating system from October 2021 to May 2022. The data were extracted from the utility bills for the testbed after the deduction of water heating system consumption.

Table 5.6: Natural gas usage by the heating system between October 2021 and May 2022.

	Oct-21	Nov-21	Dec-21	Jan-22	Feb-22	Mar-22	Apr-22	May-22	Total
Natural gas consumption by the house heating furnace (GJ)	5.7	16.32	15.03	13.25	11.46	9.89	6.7	3.72	82.07

Table 5.7 shows the details of the fees and charges for calculating the cost of natural gas usage for the house heating system for the simulation period and the entire cold season. The estimated savings for the different models that have been discussed in this chapter is presented in Table 5.8

Table 5.7: The total and the breakdown of the heating cost for the house between October 2021 and May 2022.

	NG usage	Carbon tax	Rate rider	Delivery charge	Total
Rate (CAD/GJ)	7.09	3.327	0.037	2.85	(CAD)
Cost based on 82.07 GJ usage of natural gas during the cold season (CAD)	581.9	273.0	3.0	233.9	1091.9
Cost based on 8.29 GJ usage of natural gas during the simulation period (CAD)	58.7	27.6	0.3	23.6	110.2

Table 5.8: Comparison of saving on heating cost for different heating system control scenarios.

Model	Description	Energy saving (%)	Monthly surface heating cost saving (CAD)	Projection of yearly surface heating cost saving (CAD)
Case 1	Fix thermostat temperature set at 23 °C when the building is occupied and 13 °C when the building is not occupied	10.3	11.3	112.5
Case 2	Using a programmable thermostat and user-defined set temperature to save energy by compromising the comfort level	9.5	10.5	103.7
Case 3	Adding building occupancy data to the model in Case 2	18.2	20.0	198.7
Virtual sensor model	Setting the thermostat temperature based on the desired temperature in the occupied rooms	15	16.5	163.8
Two furnaces	Using two heating units for the main floor and second floor with providing occupancy data for each unit	30.7	33.2	328.6

Chapter 6

Conclusion & Future Work

6.1 Conclusion

This thesis aimed to develop AI-based algorithms to detect occupancy in different parts of a residential building. Then, energy saving based on different occupancy-based HVAC control strategies was compared against the building's existing thermostat system. To assess the developed algorithms, data from a real building was collected (44640 sample data) and an energy model of the building was designed in EnergyPlus and experimentally validated. The results of this study are based on the preferences, behavior, and lifestyle of the occupants of the building. Any change in these assumptions may affect the results. The key finding from this thesis are:

- Design of experimental setup to collect real-time data:
 - The real-time natural gas consumption is calculated by video recording the gas meter and space-heating and water-heating burners to find the

- consumption rate for each burner
- The time that the space heating burner was On, was determined using the NEST thermostat app
 - Temperature and relative humidity were collected in five different areas of the house. In addition, two PIR sensors were used to collect the occupancy information, and one CO₂ sensor collected the CO₂ concentration in one of the bedrooms that were used as a home-based office.
 - Data collection process started in July 2021 and ended in May 2022, however, as not all the sensors were installed from the beginning, the data collected between March 2022 and May 2022 were mostly used to train the ML algorithms and energy simulation.
- Building model development and validation:
 - Sketchup, OpenStudio, and EnergyPlus were used to develop the building energy model.
 - The validation results for energy consumption showed good accuracy for the energy model by calculating NMBE and RMSE at 2% and 9% respectively.
 - validating the model for the obtained temperature in different rooms is

in the acceptable range by achieving NMBE between 0.3% to 1.8% and RMSE between 3.8% to 8.3% for different rooms in the building.

- Machine learning-based occupancy detection
 - Four ML algorithms including KNN, ANN, SVM, and DT algorithms were implemented to predict occupancy in one of the three bedrooms of the testbed. The input data to these algorithms include room temperature, relative humidity, CO₂ concentration, and day of the week.
 - Among all four algorithms employed in this study, KNN provides the best performance with a 92% Geometric Mean respectively.
 - All the models also were trained by removing CO₂ concentration as one of the input. The GM of the algorithms dropped between 11% to 22% in this situation.
- Different occupancy-based control strategies and their cost-saving
 - Five different control strategies were investigated in this study as described in Section 5.2. The results demonstrate occupancy information can reduce the energy consumption of a residential building by up to 30.7%. This can save the household up to 328.6 CAD on their yearly floor heating cost which is about 30% reduction in the yearly heating cost of the building.

- The new proposed virtual sensor model that defines the thermostat set temperature based on the desired temperature in the occupied rooms can reduce energy consumption by 15% while improving the occupants' comfort level. This is achieved by reducing the time that the occupied room temperature differs more than 1.5 °C from the desired temperature by up to 30%.

6.2 Future Work

To enhance the results from the current study, the following areas can be investigated:

- Design of an occupancy-based model predictive controller (MPC) to use occupancy information and adjust the thermostat set temperature in real-time.
- Study the proposed methods for combined heating and cooling needs of a residential building
- Augmentation of occupancy detection methods with other available data such as WiFi usage and smart appliances.
- Implementation of the designed strategies on a testbed using a programmable thermostat that receive the occupancy information as an input
- Design of an adaptive occupancy detection method to capture behavioral changes

by occupants over transition time from cold to warm season and vice versa.

- The time that creates changes in occupants' behavior should be identified and added to predictor features to train the model in real-time.
- In this study the basement was considered a non-conditioned zone but as in some buildings, the basement is heated, a testbed with a heated basement could be considered in future studies.

Bibliography

- [1] H. Heidarifar and M. Shahbakhti, “Energy saving in a residential building using occupancy information,” in *Proceedings of the Canadian Society for Mechanical Engineering International Congress (CSME-CFD-SC2023)*, May 27-31, 2023 Sherbrooke, QC, Canada., 2023.
- [2] H. Heidarifar and M. Shahbakhti, “Occupancy detection in a residential building using sensor fusion data and machine learning algorithms,” in *Proceedings of the Canadian Society for Mechanical Engineering International Congress (CSME-CFD-SC2023)*, May 27-31, 2023 Sherbrooke, QC, Canada., 2023.
- [3] X. Cao, X. Dai, and J. Liu, “Building energy-consumption status worldwide and the state-of-the-art technologies for zero-energy buildings during the past decade,” *Energy and buildings*, vol. 128, pp. 198–213, 2016.
- [4] Natural Resources Canada. “Commercial/institutional sector – canada.” (2018), [Online]. Available: https://oee.nrcan.gc.ca/corporate/statistics/neud/dpa/menus/trends/comprehensive/trends_com_ca.cfm (visited on 09/27/2022).
- [5] Natural Resources Canada. “Residential sector – canada.” (2018), [Online]. Available: https://oee.nrcan.gc.ca/corporate/statistics/neud/dpa/menus/trends/comprehensive/trends_res_ca.cfm (visited on 09/27/2022).
- [6] A. Mirakhorli and B. Dong, “Occupancy behavior based model predictive control for building indoor climate—a critical review,” *Energy and Buildings*, vol. 129, pp. 499–513, 2016.
- [7] U.S. Energy Information Administration (EIA). “Global energy consumption driven by more electricity in residential, commercial buildings.” (2019), [Online]. Available: <https://www.eia.gov/todayinenergy/detail.php?id=41753#> (visited on 09/27/2022).
- [8] S. H. Ryu and H. J. Moon, “Development of an occupancy prediction model using indoor environmental data based on machine learning techniques,” *Building and Environment*, vol. 107, pp. 1–9, 2016.
- [9] A. Standard, “Standard 55-2020 thermal environmental conditions for human occupancy,” *ASHRAE: Atlanta, GA, USA*, 2020.
- [10] Direct Energy. “What should my thermostat be set to in winter?” (2022), [Online]. Available: <https://www.directenergy.ca/learn/recommended-thermostat-settings-winter> (visited on 11/16/2022).

- [11] M. Barnes. “What temperature should you keep a vacant house at?” (2022), [Online]. Available: <https://apollocover.com/magazine/what-temperature-should-you-keep-a-vacant-house-at/> (visited on 11/16/2022).
- [12] J. Brooks, S. Kumar, S. Goyal, R. Subramany, and P. Barooah, “Energy-efficient control of under-actuated hvac zones in commercial buildings,” *Energy and Buildings*, vol. 93, pp. 160–168, 2015.
- [13] B. Dong and B. Andrews, “Sensor-based occupancy behavioral pattern recognition for energy and comfort management in intelligent buildings,” in *Proceedings of building simulation*, International Building Performance Simulation Association Vancouver, 2009, pp. 1444–1451.
- [14] M. Esrafilian-Najafabadi and F. Haghghat, “Occupancy-based hvac control systems in buildings: A state-of-the-art review,” *Building and Environment*, vol. 197, p. 107810, 2021.
- [15] L. Rueda, K. Agbossou, A. Cardenas, N. Henao, and S. Kelouwani, “A comprehensive review of approaches to building occupancy detection,” *Building and Environment*, vol. 180, p. 106966, 2020.
- [16] Natural Resources Canada. “Energy fact book 2021-2022.” (2021), [Online]. Available: <https://www.nrcan.gc.ca/science-and-data/data-and-analysis/energy-data-and-analysis/energy-facts/20061> (visited on 11/18/2022).
- [17] Statistics Canada. “In the midst of high job vacancies and historically low unemployment, canada faces record retirements from an aging labour force: Number of seniors aged 65 and older grows six times faster than children 0-14.” (2022), [Online]. Available: <https://www150.statcan.gc.ca/n1/daily-quotidien/220427/dq220427a-eng.htm?HPA=1> (visited on 11/18/2022).
- [18] Statistics Canada. “Table 38-10-0286-01 primary heating systems and type of energy.” (2023), [Online]. Available: <https://www150.statcan.gc.ca/t1/tbl1/en/tv.action?pid=3810028601> (visited on 01/15/2023).
- [19] Statistics Canada. “Household energy consumption, by type of dwelling, canada and provinces.” (2022), [Online]. Available: <https://www150.statcan.gc.ca/t1/tbl1/fr/tv.action?pid=2510006101> (visited on 11/18/2022).
- [20] Y. Ding, S. Han, Z. Tian, J. Yao, W. Chen, and Q. Zhang, “Review on occupancy detection and prediction in building simulation,” in *Building Simulation*, Springer, vol. 15, 2022, pp. 333–356.
- [21] D. Trivedi and V. Badarla, “Occupancy detection systems for indoor environments: A survey of approaches and methods,” *Indoor and Built Environment*, vol. 29, no. 8, pp. 1053–1069, 2020.
- [22] D. Aerts, J. Minnen, I. Glorieux, I. Wouters, and F. Descamps, “A method for the identification and modelling of realistic domestic occupancy sequences for building energy demand simulations and peer comparison,” *Building and environment*, vol. 75, pp. 67–78, 2014.

- [23] Y. Zhao, W. Zeiler, G. Boxem, and T. Labeodan, “Virtual occupancy sensors for real-time occupancy information in buildings,” *Building and Environment*, vol. 93, pp. 9–20, 2015.
- [24] D. Wang, C. C. Federspiel, and F. Rubinstein, “Modeling occupancy in single person offices,” *Energy and buildings*, vol. 37, no. 2, pp. 121–126, 2005.
- [25] F. Haldi and D. Robinson, “Modelling occupants’ personal characteristics for thermal comfort prediction,” *International Journal of Biometeorology*, vol. 55, no. 5, pp. 681–694, 2011.
- [26] K. Tutuncu, O. Cataltas, and M. Koklu, “Occupancy detection through light, temperature, humidity and co2 sensors using ann,” *Int. J. Ind. Electron. Electr. Eng.*, vol. 5, pp. 63–67, 2016.
- [27] B. Dong, B. Andrews, K.P. Lam, M. Hoyneck, R. Zhang, Y.S. Chiou, and D. Benitez, “An information technology enabled sustainability test-bed (itest) for occupancy detection through an environmental sensing network,” *Energy and Buildings*, vol. 42, no. 7, pp. 1038–1046, 2010.
- [28] J. Ploennigs, B. Hensel, and K. Kabitzsch, “Wireless, collaborative virtual sensors for thermal comfort,” in *Proceedings of the 2nd ACM Workshop on Embedded Sensing Systems for Energy-Efficiency in Building*, 2010, pp. 79–84.
- [29] W. Kleiminger, C. Beckel, T. Staake, and S. Santini, “Occupancy detection from electricity consumption data,” in *Proceedings of the 5th ACM Workshop on Embedded Systems For Energy-Efficient Buildings*, 2013, pp. 1–8.
- [30] A. Szczurek, M. Maciejewska, and T. Pietrucha, “Occupancy determination based on time series of CO2 concentration, temperature and relative humidity,” *Energy and Buildings*, vol. 147, pp. 142–154, 2017.
- [31] W. Kleiminger, C. Beckel, and S. Santini, “Household occupancy monitoring using electricity meters,” in *Proceedings of the 2015 ACM international joint conference on pervasive and ubiquitous computing*, 2015, pp. 975–986.
- [32] Z. Yang, N. Li, B. Becerik-Gerber, and M. Orosz, “A systematic approach to occupancy modeling in ambient sensor-rich buildings,” *Simulation*, vol. 90, no. 8, pp. 960–977, 2014.
- [33] B. W. Hobson, D. Lowcay, H. B. Gunay, A. Ashouri, and G. R. Newsham, “Opportunistic occupancy-count estimation using sensor fusion: A case study,” *Building and Environment*, vol. 159, p. 106 154, 2019.
- [34] E. Hailemariam, R. Goldstein, R. Attar, and A. Khan, “Real-time occupancy detection using decision trees with multiple sensor types,” in *Proceedings of the 2011 Symposium on Simulation for Architecture and Urban Design*, 2011, pp. 141–148.
- [35] Z. Chen, J. Xu, and Y. C. Soh, “Modeling regular occupancy in commercial buildings using stochastic models,” *Energy and Buildings*, vol. 103, pp. 216–223, 2015.

- [36] A. Beltran and A. E. Cerpa, “Optimal hvac building control with occupancy prediction,” in *Proceedings of the 1st ACM conference on embedded systems for energy-efficient buildings*, 2014, pp. 168–171.
- [37] V. L. Erickson and A. E. Cerpa, “Occupancy based demand response hvac control strategy,” in *Proceedings of the 2nd ACM Workshop on Embedded Sensing Systems for Energy-Efficiency in Building*, 2010, pp. 7–12.
- [38] B. Dong and K. P. Lam, “Building energy and comfort management through occupant behaviour pattern detection based on a large-scale environmental sensor network,” *Journal of Building Performance Simulation*, vol. 4, no. 4, pp. 359–369, 2011.
- [39] I. Richardson, M. Thomson, and D. Infield, “A high-resolution domestic building occupancy model for energy demand simulations,” *Energy and Buildings*, vol. 40, no. 8, pp. 1560–1566, 2008.
- [40] S. Hu, D. Yan, J. An, S. Guo, and M. Qian, “Investigation and analysis of chinese residential building occupancy with large-scale questionnaire surveys,” *Energy and Buildings*, vol. 193, pp. 289–304, 2019.
- [41] M. S. Gul and S. Patidar, “Understanding the energy consumption and occupancy of a multi-purpose academic building,” *Energy and Buildings*, vol. 87, pp. 155–165, 2015.
- [42] E. Soltanaghaei and K. Whitehouse, “Walksense: Classifying home occupancy states using walkway sensing,” in *Proceedings of the 3rd ACM International Conference on Systems for Energy-Efficient Built Environments*, 2016, pp. 167–176.
- [43] P. Liu, S.-K. Nguang, and A. Partridge, “Occupancy inference using pyroelectric infrared sensors through hidden markov models,” *IEEE Sensors Journal*, vol. 16, no. 4, pp. 1062–1068, 2015.
- [44] F. Wahl, M. Milenkovic, and O. Amft, “A distributed pir-based approach for estimating people count in office environments,” in *2012 IEEE 15th International Conference on Computational Science and Engineering*, IEEE, 2012, pp. 640–647.
- [45] J. Ahmad, H. Larijani, R. Emmanuel, M. Mannion, and A. Javed, “Occupancy detection in non-residential buildings—a survey and novel privacy preserved occupancy monitoring solution,” *Applied Computing and Informatics*, 2020.
- [46] J. Yang, M. Santamouris, and S. E. Lee, “Review of occupancy sensing systems and occupancy modeling methodologies for the application in institutional buildings,” *Energy and Buildings*, vol. 121, pp. 344–349, 2016.
- [47] X. Li, Y. Zhang, I. Marsic, A. Sarcevic, and R. S. Burd, “Deep learning for rfid-based activity recognition,” in *Proceedings of the 14th ACM Conference on Embedded Network Sensor Systems CD-ROM*, 2016, pp. 164–175.

- [48] L. M. Ni, Y. Liu, Y. C. Lau, and A. P. Patil, “Landmarc: Indoor location sensing using active rfid,” in *Proceedings of the First IEEE International Conference on Pervasive Computing and Communications, 2003.(PerCom 2003).*, IEEE, 2003, pp. 407–415.
- [49] O. Ardakanian, A. Bhattacharya, and D. Culler, “Non-intrusive techniques for establishing occupancy related energy savings in commercial buildings,” in *Proceedings of the 3rd ACM International Conference on Systems for Energy-Efficient Built Environments*, 2016, pp. 21–30.
- [50] A. Beltran, V. L. Erickson, and A. E. Cerpa, “Thermosense: Occupancy thermal based sensing for hvac control,” in *Proceedings of the 5th ACM Workshop on Embedded Systems For Energy-Efficient Buildings*, 2013, pp. 1–8.
- [51] T. Ekwevugbe, N. Brown, V. Pakka, and D. Fan, “Real-time building occupancy sensing using neural-network based sensor network,” in *2013 7th IEEE International Conference on Digital Ecosystems and Technologies (DEST)*, IEEE, 2013, pp. 114–119.
- [52] M. K. Masood, Y. C. Soh, and V. W.-C. Chang, “Real-time occupancy estimation using environmental parameters,” in *2015 international joint conference on neural networks (IJCNN)*, IEEE, 2015, pp. 1–8.
- [53] A. Javed, H. Larijani, A. Ahmadiania, and D. Gibson, “Smart random neural network controller for hvac using cloud computing technology,” *IEEE Transactions on Industrial Informatics*, vol. 13, no. 1, pp. 351–360, 2016.
- [54] G. Gao and K. Whitehouse, “The self-programming thermostat: Optimizing setback schedules based on home occupancy patterns,” in *Proceedings of the First ACM Workshop on Embedded Sensing Systems for Energy-Efficiency in Buildings*, 2009, pp. 67–72.
- [55] H. C. Shih, “A robust occupancy detection and tracking algorithm for the automatic monitoring and commissioning of a building,” *Energy and Buildings*, vol. 77, pp. 270–280, 2014.
- [56] Z. Chen, C. Jiang, and L. Xie, “Building occupancy estimation and detection: A review,” *Energy and Buildings*, vol. 169, pp. 260–270, 2018.
- [57] S. Zhan and A. Chong, “Building occupancy and energy consumption: Case studies across building types,” *Energy and Built Environment*, vol. 2, no. 2, pp. 167–174, 2021.
- [58] K. C. J. Simma, A. Mammoli, and S. M. Bogus, “Real-time occupancy estimation using WiFi network to optimize HVAC operation,” *Procedia Computer Science*, vol. 155, pp. 495–502, 2019.
- [59] Y. Wang, J. Liu, Y. Chen, M. Gruteser, J. Yang, and H. Liu, “E-eyes: Device-free location-oriented activity identification using fine-grained wifi signatures,” in *Proceedings of the 20th annual international conference on Mobile computing and networking*, 2014, pp. 617–628.

- [60] Z. Wang, T. Hong, M. A. Piette, and M. Pritoni, “Inferring occupant counts from wi-fi data in buildings through machine learning,” *Building and Environment*, vol. 158, pp. 281–294, 2019.
- [61] F. Stazi, F. Naspi, and M. D’Orazio, “A literature review on driving factors and contextual events influencing occupants’ behaviours in buildings,” *Building and Environment*, vol. 118, pp. 40–66, 2017.
- [62] R. Analytics, “Validating the impact of programmable thermostats,” *Middletown, CT*, 2007.
- [63] P. Baillargeon, L. Megdal, M. Norman, and C. Acocella, “Billing analysis & environment that “re-sets” savings for programmable thermostats in new homes,” in *Proceedings from International Energy Program Evaluation Conference*, 2009, pp. 1–10.
- [64] J. Lu, T. Sookoor, V. Srinivasan, G. Gao, B. Holben, J. Stankovic, E. Field, and K. Whitehouse, “The smart thermostat: Using occupancy sensors to save energy in homes,” in *Proceedings of the 8th ACM conference on embedded networked sensor systems*, 2010, pp. 211–224.
- [65] D. Urieli and P. Stone, “A learning agent for heat-pump thermostat control,” in *Proceedings of the 2013 international conference on Autonomous agents and multi-agent systems*, 2013, pp. 1093–1100.
- [66] D. Liu, X. Guan, Y. Du, and Q. Zhao, “Measuring indoor occupancy in intelligent buildings using the fusion of vision sensors,” *Measurement Science and Technology*, vol. 24, no. 7, p. 074023, 2013.
- [67] T. Vafeiadis, S. Zikos, G. Stavropoulos, D. Ioannidis, S. Krinidis, D. Tzovaras, and K. Moustakas, “Machine learning based occupancy detection via the use of smart meters,” in *2017 International Symposium on Computer Science and Intelligent Controls (ISCSIC)*, IEEE, 2017, pp. 6–12.
- [68] R. Melfi, B. Rosenblum, B. Nordman, and K. Christensen, “Measuring building occupancy using existing network infrastructure,” in *2011 International Green Computing Conference and Workshops*, IEEE, 2011, pp. 1–8.
- [69] P. Kraipeerapun and S. Amornsamankul, “Room occupancy detection using modified stacking,” in *Proceedings of the 9th International Conference on Machine Learning and Computing*, 2017, pp. 162–166.
- [70] H. Li, D. Yu, and J. E. Braun, “A review of virtual sensing technology and application in building systems,” *HVAC & Research*, vol. 17, no. 5, pp. 619–645, 2011.
- [71] Y. Hong, S. Yoon, Y. S. Kim, and H. Jang, “System-level virtual sensing method in building energy systems using autoencoder: Under the limited sensors and operational datasets,” *Applied Energy*, vol. 301, p. 117458, 2021.

- [72] G. Li, H. Chen, Y. Hu, J. Wang, Y. Guo, J. Liu, H. Li, R. Huang, H. Lv, and J. Li, “An improved decision tree-based fault diagnosis method for practical variable refrigerant flow system using virtual sensor-based fault indicators,” *Applied Thermal Engineering*, vol. 129, pp. 1292–1303, 2018.
- [73] W. Kim and J. E. Braun, “Development, implementation, and evaluation of a fault detection and diagnostics system based on integrated virtual sensors and fault impact models,” *Energy and Buildings*, vol. 228, p. 110368, 2020.
- [74] N. Cotrufo and R. Zmeureanu, “Virtual outdoor air flow meter for an existing hvac system in heating mode,” *Automation in Construction*, vol. 92, pp. 166–172, 2018.
- [75] D. Yu, H. Li, and M. Yang, “A virtual supply airflow rate meter for rooftop air-conditioning units,” *Building and environment*, vol. 46, no. 6, pp. 1292–1302, 2011.
- [76] Y. Bae, S. Bhattacharya, B. Cui, S. Lee, Y. Li, L. Zhang, P. Im, V. Adetola, D. Vrabie, M. Leach, “Sensor impacts on building and hvac controls: A critical review for building energy performance,” *Advances in Applied Energy*, vol. 4, p. 100068, 2021.
- [77] J. Ploennigs, A. Ahmed, B. Hensel, P. Stack, and K. Menzel, “Virtual sensors for estimation of energy consumption and thermal comfort in buildings with underfloor heating,” *Advanced Engineering Informatics*, vol. 25, no. 4, pp. 688–698, 2011.
- [78] M. Alhashme and N. Ashgriz, “A virtual thermostat for local temperature control,” *Energy and buildings*, vol. 126, pp. 323–339, 2016.
- [79] SMW Refrigeration and Heating, LLC. “How gas furnaces work.” (2022), [Online]. Available: <https://smwac.net/hvac-knowledge/how-gas-furnaces-work/> (visited on 09/08/2022).
- [80] H. W. Coleman and W. G. Steele, *Experimentation, validation, and uncertainty analysis for engineers*. John Wiley & Sons, 2018.
- [81] U.S. Department of Energy. “Energyplus.” (2023), [Online]. Available: <https://energyplus.net/> (visited on 04/14/2023).
- [82] University of Wisconsin System. “TRNSYS 18.” (2023), [Online]. Available: <https://sel.me.wisc.edu/trnsys/features/features.html> (visited on 04/14/2023).
- [83] TRANE Co. “Trace 3D plus.” (2023), [Online]. Available: <https://www.trane.com/commercial/north-america/us/en/products-systems/design-and-analysis-tools/trane-design-tools/trace-3d-plus.html> (visited on 04/14/2023).
- [84] Government of Alberta. “Current and historical alberta weather station data viewer.” (2022), [Online]. Available: <https://acis.alberta.ca/acis/weather-data-viewer.jsp> (visited on 08/24/2022).
- [85] Big Ladder Software. “Engineering reference — energyplus 8.0.” (2022), [Online]. Available: <https://bigladdersoftware.com/epx/docs/8-0/engineering-reference/page-021.html> (visited on 04/14/2023).

- [86] G. Ramos Ruiz and C. Fernandez Bandera, “Validation of calibrated energy models: Common errors,” *Energies*, vol. 10, no. 10, p. 1587, 2017.
- [87] L. M. Candanedo and V. Feldheim, “Accurate occupancy detection of an office room from light, temperature, humidity and CO2 measurements using statistical learning models,” *Energy and Buildings*, vol. 112, pp. 28–39, 2016.
- [88] L. Kozma, “K nearest neighbors algorithm (knn),” *Helsinki University of Technology*, vol. 32, 2008.
- [89] K. Sudheer, A. Gosain, D Mohana Rangan, and S. Saheb, “Modelling evaporation using an artificial neural network algorithm,” *Hydrological Processes*, vol. 16, no. 16, pp. 3189–3202, 2002.
- [90] A. Norouzi Yengeje, “Machine learning and deep learning for modeling and control of internal combustion engines,” 2022.
- [91] W. S. Noble, “What is a support vector machine?” *Nature biotechnology*, vol. 24, no. 12, pp. 1565–1567, 2006.
- [92] A. Ng, *CS229 lecture notes*, 2000.
- [93] Y. Y. Song and L. Ying, “Decision tree methods: Applications for classification and prediction,” *Shanghai archives of psychiatry*, vol. 27, no. 2, p. 130, 2015.
- [94] A. Tharwat, “Classification assessment methods,” *Applied Computing and Informatics*, vol. 17, no. 1, pp. 168–192, 2021.
- [95] X. Ying, “An overview of overfitting and its solutions,” in *Journal of physics: Conference series*, IOP Publishing, vol. 1168, 2019, p. 022 022.
- [96] R. Pandey, S. K. Khatri, N. K. Singh, and P. Verma, *Artificial intelligence and machine learning for EDGE computing*. Academic Press, 2022.
- [97] Monnit Co. “Wireless carbon dioxide (CO2) sensor.” (2023), [Online]. Available: <https://www.monnit.com/products/sensors/gas-detection/carbon-dioxide-detector/MNS2-9-W2-GS-C2> (visited on 04/26/2023).
- [98] US. Energy information administration (EIA). “Residential energy consumption survey (recs), 2020.” (2021), [Online]. Available: <https://www.eia.gov/consumption/residential/data/2020/#sh> (visited on 03/26/2023).

Appendix A: M.Sc. Publications

A.1 Peer Reviewed Journal Papers

1. A. Norouzi, **H. Heidarifar**, H. Borhan, M. Shahbakhti, and C. R. Koch. Integrating Machine Learning and Model Predictive Control for automotive applications: A Review and future directions. *Engineering Applications of Artificial Intelligence*, Vol. 120, 31 pages, (2023): 105878.
2. A. Norouzi, **H. Heidarifar**, A. Borhan, M. Shahbakhti, and C.R. Koch, Application of Model Predictive Control for Internal Combustion Engines (ICEs) Control: A review and future directions, *Energies*, Vol. 14(19), 40 pages, (2021): 6251.

A.2 Refereed Conference Papers in Proceedings

1. **H. Heidarifar** and M. Shahbakhti, “Energy saving in a residential building using occupancy information,” in *Proceedings of the Canadian Society for Mechanical Engineering International Congress (CSME-CFD-SC2023)*, May 27-31, 2023 Sherbrooke, QC, Canada., 2023.
2. **H. Heidarifar** and M. Shahbakhti, “Occupancy detection in a residential building using sensor fusion data and machine learning algorithms,” in *Proceedings of the Canadian Society for Mechanical Engineering International Congress (CSME- CFD-SC2023)*, May 27-31, 2023 Sherbrooke, QC, Canada., 2023.

Appendix B: Thesis Files

B.1 Program and Data file Summary

The following files were used in this thesis.

B.1.1 Chapter 1

Table B.1: Chapter 1 Figure files

File name	File Description
number of studies.jpg, Number of slides.xlsx	Figure 1.1
Residential Energy Consumption.jpg	Figure 1.2 (a)
Commercial Energy Consumption.jpg	Figure 1.2 (b)
Space heating source of energy.jpg	Figure 1.2 (c)
Type of dwelling.jpg, Type of dwelling.xlsx	Figure 1.3
Occupancy resolution.jpg	Figure 1.5

B.1.2 Chapter 2

Table B.2: Chapter 2 Figure files

File name	File Description
House north view.jpg	Figure 2.1
Second Floor.jpg, 3D model.skp	Figure 2.2 (a)
First Floor.jpg, 3D model.skp	Figure 2.2 (b)
Basement.jpg, 3D model.skp	Figure 2.2 (c)
First Floor Layout.jpg, Floor plan.dwg	Figure 2.3 (a)
Second Floor Layout.jpg, floor plan.dwg	Figure 2.3 (b)
Furnace.jpg	Figure 2.4 (a)
Water heating.jpg	Figure 2.4 (b)
Heating system schematic.jpg	Figure 2.5
SensorsPicture.jpg	Figure 2.6
Sensors First floor.jpg	Figure 2.7 (a)
Sensors Second floor.jpg	Figure 2.7 (b)
Power meter.jpg	Figure 2.8 (a)
water heater pilot.jpg	Figure 2.8 (b)
water heatre on.jpg	Figure 2.8 (c)
Nest sample.jpg	Figure 2.8 (d)
Outside Temperature.jpg, Outside temperature.xlsx	Figure 2.9

B.1.3 Chapter 3

Table B.3: Chapter 3 Figure files

File name	File Description
ModelingProcess.jpg	Figure 3.1
Second floor Thermal1.jpg, Model for validation.osm	Figure 3.2 (a)
Main floor Thermal1.jpg, Model for validation.osm	Figure 3.2 (b)
Basement thermal.jpg, Model for validation.osm	Figure 3.2 (c)
Airflow.jpg	Figure 3.3
NGValidation.png, Data for NG consumption validation.xlsx	Figure 3.4
Foyer data validation temperature.jpg, Temperature Validation.xlsx	Figure 3.5 (a)
Living room data validation temperature.jpg, Temperature Validation.xlsx	Figure 3.5 (b)
Master bedroom data validation temperature.jpg, Temperature Validation.xlsx	Figure 3.6 (a)
Office data validation temperature.jpg, Temperature Validation.xlsx	Figure 3.6 (b)

B.1.4 Chapter 4

Table B.4: Chapter 4 Figure files

File name	File Description
Classifiers Output Input.jpg	Figure 4.1
KNN.jpg	Figure 4.2
ANN.jpg	Figure 4.3
SVM.jpg	Figure 4.4
DT.jpg	Figure 4.5
overfitting.png, Overfitting.xlsx	Figure 4.6
Confusion with CO2.png, Confusion matrix.pptx	Figure 4.7
GM-without co2.png, GM-without co2.xlsx	Figure 4.8
Adding more data.png, Adding more data.fig	Figure 4.9
GM for time lag.png, GM for time lag.xlsx	Figure 4.10
GM for time lag.png, GM for time lag.xlsx	Figure 4.10
GM for time lag.png, GM for time lag.xlsx	Figure 4.10
GM for time lag.png, GM for time lag.xlsx	Figure 4.10

Table B.5: Chapter 4 Matlab files

File name	File Description
ANN-trainClassifier.m	Model used to train and test occupancy prediction
DT-trainClassifier.m	Model used to train and test occupancy prediction
KNN-trainClassifier.m	Model used to train and test occupancy prediction
SVM-trainClassifier.m	Model used to train and test occupancy prediction

B.1.5 Chapter 5

Table B.6: Chapter 5 Figure files

File name	File Description
Type of thermostats.png, Type of thermostats.xlsx	Figure 5.1
Heating equipment control.png, Heating equipment control.xlsx	Figure 5.2
temperature difference in rooms.png, temperature.xlsx	Figure 5.3
temperature difference in rooms1.png, temperature1.xlsx	Figure 5.4
Schedule NEST.png, Schedule NEST.fig	Figure 5.5
Set Temperature for case 2 and 3.png, Set Temperature for case 2 and 3.fig	Figure 5.6
Daily consumption.png, NG daily consumption.xlsx	Figure 5.7
ANN model.png, Virtual thermostat model.pptx	Figure 5.8 (a)
ANN model1.png, Virtual thermostat model.pptx	Figure 5.8 (b)
last step virtual model.png, Virtual thermostat model.pptx	Figure 5.9
Daily consumption 2 furnace.png, NG daily consumption.xlsx	Figure 5.10

Table B.7: Chapter 5 Simulation and Matlab files

File name	File Description
Baseline Constant Temperature.osm	To simulate baseline energy consumption
Case 1 model 23 while occupied.osm	Energy model for Case 1
Case 2 Occupants set temperature.osm	Energy model for Case 2
Case 3 Occupancy information and occupants set temperature.osm	Energy model for Case 3
2 Heating units.osm	Energy model for 2 heating units
Constant temperature for April 10 to be compared with virtual thermostat.osm	Energy model for virtual sensor
VirtualSensorTemPrediction.m	Matlab code for virtual thermostat model

B.1.6 Collected data

Table B.8: Data files

File name	File Description
Master File.xlsx	Data collected from sensors during the study
Experimental data.xlsx	Part of Master File used for occupancy prediction
Data for NG consumption validation.xlsx	Data used for NG consumption validation
Temperature Validation.xlsx	Data used to validate temperature
Uncertainty.xlsx	Data used to calculate variable uncertainty

Appendix C: Sensors Specification

C.1 OMEGA WiFi Wireless Temperature and Humidity Data Loggers

1 YEAR
WARRANTY

OMEGA CARE
Extended Warranty
Program



Ω OMEGA® **User's Guide**

**Shop online at
omega.com**

**e-mail: info@omega.com
For latest product manuals:
omegamanual.info**



OM-EL-WiFi-TH **Temperature/ Humidity** **Data Logger**



OMEGAnet® Online Service
omega.com

Internet e-mail
info@omega.com

Servicing North America:

U.S.A.: Omega Engineering, Inc., One Omega Drive, P.O. Box 4047
ISO 9001 Certified Stamford, CT 06907-0047 USA
Toll Free: 1-800-826-6342 TEL: (203) 359-1660
FAX: (203) 359-7700 e-mail: info@omega.com

Canada: 976 Bergar
Laval (Quebec), H7L 5A1 Canada
Toll-Free: 1-800-826-6342 TEL: (514) 856-6928
FAX: (514) 856-6886 e-mail: info@omega.com

For immediate technical or application assistance:

U.S.A. and Canada: Sales Service: 1-800-826-6342 / 1-800-TC-OMEGA®
Customer Service: 1-800-622-2378 / 1-800-622-BEST®
Engineering Service: 1-800-872-9436 / 1-800-USA-WHEN®

**Mexico/
Latin America:** En Español: 001 (203) 359-7803 FAX: 001 (203) 359-7807
info@omega.com.mx e-mail: espanol@omega.com

Servicing Europe:

Benelux: Managed by the United Kingdom Office
Toll-Free: 0800 099 3344 TEL: +31 20 347 21 21
FAX: +31 20 643 46 43 e-mail: sales@omegaeng.nl

Czech Republic: Frystatska 184
733 01 Karviná, Czech Republic
Toll-Free: 0800-1-66342 TEL: +420-59-6311899
FAX: +420-59-6311114 e-mail: info@omegashop.cz

France: Managed by the United Kingdom Office
Toll-Free: 0800 466 342 TEL: +33 (0) 161 37 29 00
FAX: +33 (0) 130 57 54 27 e-mail: sales@omega.fr

Germany/ Austria: Daimlerstrasse 26
D-75392 Deckenpfronn, Germany
Toll-Free: 0800 6397678 TEL: +49 (0) 7056 9398-0
FAX: +49 (0) 7056 9398-29 e-mail: info@omega.de

United Kingdom: OMEGA Engineering Ltd.
ISO 9001 Certified One Omega Drive, River Bend Technology Centre, Northbank
Irlam, Manchester M44 5BD United Kingdom
Toll-Free: 0800-488-488 TEL: +44 (0) 161 777-6611
FAX: +44 (0) 161 777-6622 e-mail: sales@omega.co.uk

It is the policy of OMEGA Engineering, Inc. to comply with all worldwide safety and EMC/EMI regulations that apply. OMEGA is constantly pursuing certification of its products to the European New Approach Directives. OMEGA will add the CE mark to every appropriate device upon certification.

The information contained in this document is believed to be correct, but OMEGA accepts no liability for any errors it contains, and reserves the right to alter specifications without notice.

WARNING: These products are not designed for use in, and should not be used for, human applications.

OM-EL-WiFi-TH

WiFi Temperature & Humidity Data Logging Sensor

FEATURES

- Temperature and humidity data logging sensor
- WiFi capability and integrated display
- Wireless connectivity to PC via WiFi
- Easy sensor set-up using free PC software
- View and analyze multiple sensors using the PC application, including immediate graphing of historic data
- Measurement range from -20 to +60 °C (-4 to +140 °F)
- 802.11b compliant
- Capable of logging greater than 500,000 data set entries
- Sensor memory stores all data even if WiFi is temporarily disconnected
- IP55
- Rechargeable internal lithium polymer battery
- Configurable high and low alarms with indicator
- Max & Min readings
- Low battery indicator
- WiFi connection indicator
- USB port used for recharging
- Supplied with wall bracket and micro USB lead

ORDERING INFORMATION

WiFi Temperature & Humidity Data Logging Sensor OM-EL-WiFi-TH



The OM-EL-WiFi-TH sensor measures the temperature and humidity of the environment in which it is situated. Data is transmitted wirelessly via a WiFi network to a PC and viewed using a free software package. During configuration the sensor will search for an existing wireless network while physically connected to the PC. It can then be placed anywhere within range of the network. If the sensor temporarily loses connectivity with the network, it will log readings until it is able to communicate again with the PC application (max 60 days at 10 second sample interval). The range of the sensor can be increased by using WiFi extenders.

This OM-EL-WiFi-TH is a low powered battery device. When configured using typical sampling periods (e.g. once every 60 seconds) the sensor will operate for over one year. The battery can then be recharged via a PC or USB +5V wall adapter using the USB lead provided.

The battery is safely charged when the unit is operating between 0 to +40 °C (+32 to +104 °F). It is protected against charging outside this temperature range. Sensor readings may be inaccurate during battery charging.

The software installed on the PC will allow set-up, data logging and data review. Set-up features will include sensor name, °C/°F, sample rate, and high/low alarms. Once configured, historic data can be viewed via the graphing tool or exported into Excel. This software is available for free from www.omega.com.

www.omega.com

This sensor stands alone by itself on a horizontal surface and comes with a wall bracket that can be screwed onto a wall or flat surface. The sensor clips into the bracket.

All OM-EL-WiFi-TH sensors are thoroughly tested pre-release but the sensor may experience compatibility issues with certain WiFi networks. In this instance we recommend the use of network accessories available on the Omega website.

Specifications	Minimum	Typical	Maximum	Unit
Battery life		>1*		Year
USB supply voltage	4.5v		5.5v	V d.c.
Temperature measurement range	-20 (-4)		+60 (+140)	°C (°F)
Internal resolution		+/- 0.5		°C
Temperature accuracy (overall error between -10°C and +60°C)		+/- 1.0		°C
Humidity accuracy (overall error between 20%RH and 80%RH)		+/- 3.0		%RH
Logging rate (user configurable)	Every 10s	30 seconds	Every 12hrs	Transmission rate
Operating temperature range	-20 (-4)		+60 (+140)	°C (°F)

* Typical but will be less if frequent transmissions

Warning - do not exceed operating temperatures

EXAMPLE OF UNIT WHILE PHYSICALLY CONNECTED TO PC DURING SET-UP



HARDWARE

- Battery: Rechargeable via USB connection.
- ARM MCU.
- 1x microUSB Type B (bottom of unit) for connection of unit to PC. 0.5m USB cable supplied.

PHYSICAL DIMENSIONS

All dimensions in millimetres (mm)

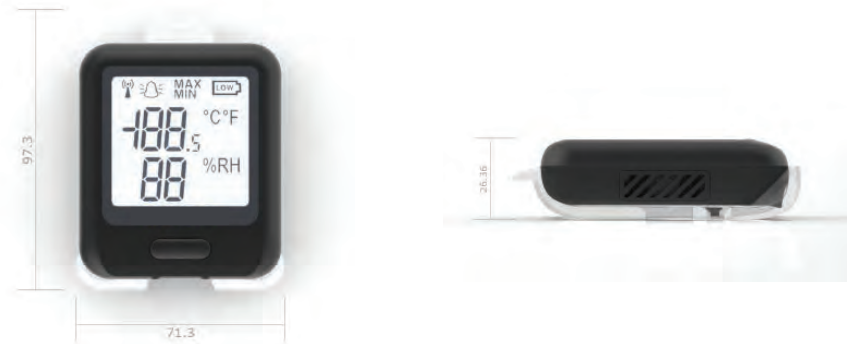

www.omega.com

LCD SCREEN SHOTS



ADDITIONAL FUNCTIONALITY

When the user cycles through to the Received Signal Strength Indicator (RSSI) screen the unit automatically transmits a dummy message every 2 seconds to enable an RSSI reading to be displayed. If there is any outstanding data waiting to be transmitted, this data will be sent at the same time but if not it'll just send the dummy message and the next data package will be sent as per the unit configuration.

When on Max or Min screen, holding the button for 3 seconds will clear the stored values.

The sensor can be restarted by holding the button for 10 seconds until the screen blanks and LOW is shown flashing in the top right hand corner of the display. The sensor will retain all settings but will lose any data that has not been transferred to the PC. The sensor can be reset to factory state by holding the button for 20 seconds but this will delete all settings and stored data.

Note: neither the restart or the reset will delete data already transferred to your PC.

www.omega.com

WARRANTY/DISCLAIMER

OMEGA ENGINEERING, INC. warrants this unit to be free of defects in materials and workmanship for a period of **13 months** from date of purchase. OMEGA's WARRANTY adds an additional one (1) month grace period to the normal **one (1) year product warranty** to cover handling and shipping time. This ensures that OMEGA's customers receive maximum coverage on each product.

If the unit malfunctions, it must be returned to the factory for evaluation. OMEGA's Customer Service Department will issue an Authorized Return (AR) number immediately upon phone or written request. Upon examination by OMEGA, if the unit is found to be defective, it will be repaired or replaced at no charge. OMEGA's WARRANTY does not apply to defects resulting from any action of the purchaser, including but not limited to mishandling, improper interfacing, operation outside of design limits, improper repair, or unauthorized modification. This WARRANTY is VOID if the unit shows evidence of having been tampered with or shows evidence of having been damaged as a result of excessive corrosion; or current, heat, moisture or vibration; improper specification; misapplication; misuse or other operating conditions outside of OMEGA's control. Components in which wear is not warranted, include but are not limited to contact points, fuses, and triacs.

OMEGA is pleased to offer suggestions on the use of its various products. However, OMEGA neither assumes responsibility for any omissions or errors nor assumes liability for any damages that result from the use of its products in accordance with information provided by OMEGA, either verbal or written. OMEGA warrants only that the parts manufactured by the company will be as specified and free of defects. OMEGA MAKES NO OTHER WARRANTIES OR REPRESENTATIONS OF ANY KIND WHATSOEVER, EXPRESSED OR IMPLIED, EXCEPT THAT OF TITLE, AND ALL IMPLIED WARRANTIES INCLUDING ANY WARRANTY OF MERCHANTABILITY AND FITNESS FOR A PARTICULAR PURPOSE ARE HEREBY DISCLAIMED. LIMITATION OF LIABILITY: The remedies of purchaser set forth herein are exclusive, and the total liability of OMEGA with respect to this order, whether based on contract, warranty, negligence, indemnification, strict liability or otherwise, shall not exceed the purchase price of the component upon which liability is based. In no event shall OMEGA be liable for consequential, incidental or special damages.

CONDITIONS: Equipment sold by OMEGA is not intended to be used, nor shall it be used: (1) as a "Basic Component" under 10 CFR 21 (NRC), used in or with any nuclear installation or activity; or (2) in medical applications or used on humans. Should any Product(s) be used in or with any nuclear installation or activity, medical application, used on humans, or misused in any way, OMEGA assumes no responsibility as set forth in our basic WARRANTY/DISCLAIMER language, and, additionally, purchaser will indemnify OMEGA and hold OMEGA harmless from any liability or damage whatsoever arising out of the use of the Product(s) in such a manner.

RETURN REQUESTS/INQUIRIES

Direct all warranty and repair requests/inquiries to the OMEGA Customer Service Department. BEFORE RETURNING ANY PRODUCT(S) TO OMEGA, PURCHASER MUST OBTAIN AN AUTHORIZED RETURN (AR) NUMBER FROM OMEGA'S CUSTOMER SERVICE DEPARTMENT (IN ORDER TO AVOID PROCESSING DELAYS). The assigned AR number should then be marked on the outside of the return package and on any correspondence.

The purchaser is responsible for shipping charges, freight, insurance and proper packaging to prevent breakage in transit.

FOR **WARRANTY** RETURNS, please have the following information available BEFORE contacting OMEGA:

1. Purchase Order number under which the product was PURCHASED,
2. Model and serial number of the product under warranty, and
3. Repair instructions and/or specific problems relative to the product.

FOR **NON-WARRANTY** REPAIRS, consult OMEGA for current repair charges. Have the following information available BEFORE contacting OMEGA:

1. Purchase Order number to cover the COST of the repair,
2. Model and serial number of the product, and
3. Repair instructions and/or specific problems relative to the product.

OMEGA's policy is to make running changes, not model changes, whenever an improvement is possible. This affords our customers the latest in technology and engineering.

OMEGA is a registered trademark of OMEGA ENGINEERING, INC.

© Copyright 2012 OMEGA ENGINEERING, INC. All rights reserved. This document may not be copied, photocopied, reproduced, translated, or reduced to any electronic medium or machine-readable form, in whole or in part, without the prior written consent of OMEGA ENGINEERING, INC.

Where Do I Find Everything I Need for Process Measurement and Control? **OMEGA...Of Course!** *Shop online at omega.comSM*

TEMPERATURE

- ☑ Thermocouple, RTD & Thermistor Probes, Connectors, Panels & Assemblies
- ☑ Wire: Thermocouple, RTD & Thermistor
- ☑ Calibrators & Ice Point References
- ☑ Recorders, Controllers & Process Monitors
- ☑ Infrared Pyrometers

PRESSURE, STRAIN AND FORCE

- ☑ Transducers & Strain Gages
- ☑ Load Cells & Pressure Gages
- ☑ Displacement Transducers
- ☑ Instrumentation & Accessories

FLOW/LEVEL

- ☑ Rotameters, Gas Mass Flowmeters & Flow Computers
- ☑ Air Velocity Indicators
- ☑ Turbine/Paddlewheel Systems
- ☑ Totalizers & Batch Controllers

pH/CONDUCTIVITY

- ☑ pH Electrodes, Testers & Accessories
- ☑ Benchtop/Laboratory Meters
- ☑ Controllers, Calibrators, Simulators & Pumps
- ☑ Industrial pH & Conductivity Equipment

DATA ACQUISITION

- ☑ Data Acquisition & Engineering Software
- ☑ Communications-Based Acquisition Systems
- ☑ Plug-in Cards for Apple, IBM & Compatibles
- ☑ Data Logging Systems
- ☑ Recorders, Printers & Plotters

HEATERS

- ☑ Heating Cable
- ☑ Cartridge & Strip Heaters
- ☑ Immersion & Band Heaters
- ☑ Flexible Heaters
- ☑ Laboratory Heaters

ENVIRONMENTAL MONITORING AND CONTROL

- ☑ Metering & Control Instrumentation
- ☑ Refractometers
- ☑ Pumps & Tubing
- ☑ Air, Soil & Water Monitors
- ☑ Industrial Water & Wastewater Treatment
- ☑ pH, Conductivity & Dissolved Oxygen Instruments

M5179/0712

C.2 Fluke 922 Airflow Meter/ Micro Manometer

FLUKE®

Fluke 922

Airflow Meter/ Micromanometer

Technical Data



Today's HVAC technicians need a simple solution for diagnosing ventilation issues. The Fluke 922 makes airflow measurements easy by combining pressure, air flow, and velocity into a single, rugged meter. Compatible with most pitot tubes, the Fluke 922 allows technicians to conveniently enter their duct shape and dimensions for maximum measurement accuracy.

The Fluke 922 Airflow Meter helps you:

- Monitor air pressure across key HVAC components
- Ensure proper air flow balance
- Promote good indoor air quality
- Maintain a comfortable environment

Use the Fluke 922 to:

- Measure pressure drops across filters and coils
- Match ventilation to occupant loads
- Monitor indoor vs. outdoor pressure relationships and manage the building envelope
- Perform duct traversals for accurate airflow readings

Features:

- Powerful meter provides differential and static pressure, air velocity and flow readings
- Rugged design built for field use
- Easy to use without sacrificing performance
- User-defined duct shape and size for maximum airflow accuracy
- Convenient colored hoses help you properly diagnose pressure readings
- Bright, backlit display for clear viewing in all environments
- Min/Max/Average/Hold functions for easy data analysis
- Auto power off saves battery life



Shop for Fluke products online at: www.MyFlukeStore.com 1.877.766.5412

Fluke 922 Airflow Meter Specifications

Feature	Range	Resolution	Accuracy
Operating Specifications			
Air Pressure	± 4000 Pascals ± 16 in H ₂ O ± 400 mm H ₂ O ± 40 mbar ± 0.6 PSI	1 Pascal 0.001 in H ₂ O 0.1 mm H ₂ O 0.01 mbar 0.0001 PSI	± 1 % + 1 Pascal ± 1 % + 0.01 in H ₂ O ± 1 % + 0.1 mm H ₂ O ± 1 % + 0.01 mbar ± 1 % + 0.0001 PSI
Air Velocity	250 to 16,000 fpm 1 to 80 m/s	1 fpm 0.001 m/s	± 2.5 % of reading at 2000 fpm (10.00 m/s)
Air Flow (Volume)	0 to 99,999 cfm 0 to 99,999 m ³ /hr 0 to 99,999 l/s	1 cfm 1 m ³ /hr 1 l/s	Accuracy is a function of velocity and duct size
Temperature	0 °C to 50 °C 32 °F to 122 °F	0.1 °C 0.1 °F	± 1 % + 2 °C ± 1 % + 4 °F
General Specifications			
Operating Temperature	0 °C to +50 °C (+32 °F to +122 °F)		
Storage Temperature	-40 °C to +60 °C (-40 °F to +140 °F)		
Operating Relative Humidity	0 % to 90 %, non-condensing		
IP Rating	IP40		
Operating Altitude	2000 m		
Storage Altitude	12000 m		
EML, RFL, EMC	Meets requirements for EN61326-1		
Vibration	MIL-PREF-28800F, Class 3		
Max Pressure at Each Port	10 PSI		
Data Storage	99 readings		
Warranty	2 years		
Power	Four AA batteries		
Typical Battery Life	375 hours without backlight, 80 hours with backlight		



Fluke 922 comes complete with the following:
Fluke 922 Airflow Meter, Two Rubber Hoses, Wrist Strap, Four AA Batteries 1.5 V Alkaline, Users Manual and Soft Carrying Case



Fluke 922/Kit comes complete with the following:
Fluke 922 Airflow Meter, 12 in. pitot tube, ToolPak™, Two Rubber Hoses, Wrist Strap, Four AA Batteries 1.5 V Alkaline, Users Manual and Hard Carrying Case

Ordering Information

- Fluke-922** Airflow Meter
- Fluke-922/Kit** Airflow Meter with 12 in Pitot Tube
- PT12** Pitot Tube, 12 in



Optional accessories

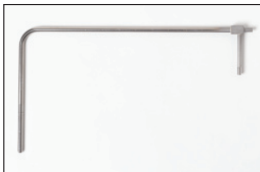

PT12
Pitot Tube, 12 in



TPAK
ToolPak™

Fluke. Keeping your world up and running.®

Fluke Corporation
PO Box 9090, Everett, WA USA 98206

Fluke Europe B.V.
PO Box 1186, 5602 BD Eindhoven, The Netherlands

For more information call:
In the U.S.A. (800) 443-5853 or Fax (425) 446-5116
In Europe/M-East/Africa +31 (0) 40 2675 200 or Fax +31 (0) 40 2675 222
In Canada (800)-36-FLUKE or Fax (905) 890-6866
From other countries +1 (425) 446-5500 or Fax +1 (425) 446-5116
Web access: <http://www.fluke.com>

©2006, 2007 Fluke Corporation. All rights reserved. Specifications subject to change without notice.

Shop for Fluke products online at: www.MyFlukeStore.com **1.877.766.5412**

C.3 Elitech RC-4HC Temperature and Humidity Data Loggers

RC-4/RC-4HA/RC-4HC Quick Start Guide

Software download: www.elitechlog.com/softwares

Install Battery

1. Use a proper tool (such as a coin) to loosen the battery cover.



2. Install the battery with "+" side upward and keep it under the metal connector.



3. Put the cover back and tighten the cover.



Note: Do not remove the battery when the logger is running. Please change it when necessary.





1

Install Software

1. Please visit www.elitechlog.com/softwares. Select and download the software.

2. Double click to open the zip file. Follow the prompts to install it.
3. When the installation is completed, the ElitechLog software will be ready to use. Please disable the firewall or close the antivirus software if necessary.

Start/Stop Logger

1. Connect the logger to a computer to sync the logger time or configure parameters as needed.
2. Press and hold  to start the logger until  shows. The logger starts logging.
3. Press and release  to shift between display interfaces.
4. Press and hold  to stop the logger until  shows. The logger stops logging.

Please note all the recorded data cannot be changed for security reasons.

2

Configure Software

1. Download Data: ElitechLog software will automatically access the logger and download the recorded data to local computer if it finds the logger is connected. If not, manually click "Download Data" to download the data.

2. Filter Data: Click "Filter Data" under Graph tab to select and view your desired time range of the data.

3. Export data: Click "Export Data" to save Excel/PDF format files to local computer.

4. Configure options: Set logger time, log interval, start delay, high/low limit, date / time format, email etc. (Check User Manual for default parameters).

Note: New configuration will initialize previous recorded data. Please make sure to back up all necessary data before you apply new configurations.

Refer to "Help" for more advanced functions. More product information are available on the company website www.elitechlog.com.

3

IF...	PLEASE...
only a few data was logged.	check whether the battery is installed, or check if it was installed correctly.
the logger does not log after start up.	check whether start delay is enabled in the software configuration.
the logger cannot stop logging by pressing the button  .	check parameter settings to see if button customization is enabled (default configuration is disabled).

4

Troubleshooting

▲ Important !

- ◆ Please store the logger in indoor environment.
- ◆ Do not use the logger in corrosive liquid or excessive heat environment.
- ◆ If this is the first time you use the logger, it is suggested to connect the logger to a computer to sync the time.
- ◆ Please dispose or handle the waste logger properly by local legislation.

Technical Specifications (RC-4)

Recording Options	Multi-Use	Certifications	EN12830, CE, RoHS
Temperature Range	30°C to 60°C (Internal sensor) -40°C to 85°C (optional external sensor)	Validation Certificate	Hardcopy
Temperature Accuracy	±0.5(-20°C/+40°C); ±1.0(other range)	Software	ElitechLog Win or Mac (latest version)
Temperature Resolution	0.1°C	Report Generation	PDF&Excel report by Elitech software
Data Storage Capacity	16,000 readings	Password Protection	NONE
Shelf Life/Battery	1 years/CR2450 button cell	Connection Interface	Mini USB
Recording Interval	15 minutes (standard, others on request)	Alarm Configuration	Optional, only 2 points
Dimensions	84mmx44mmx20mm(LxWxH)	Reprogrammable	With free Elitech Win or MAC software
Weight	35g	Startup Mode	Button
		Stop Mode	Button, software or stop when full
			1. Depending on optimal storage conditions (±15°C to +23°C/45% to 75% rH)

Technical Specifications (RC-4HA/RC-4HC)

Recording Options	Multi-Use	Certifications	EN12830, CE, RoHS
Temperature Range	-30°C to 60°C (Internal sensor) -40°C to 85°C (optional external sensor)	Validation Certificate	Hardcopy
Humidity Range	10%-99%	Software	ElitechLog Win or Mac (latest version)
Accuracy	±0.5(-20°C/+40°C); ±1.0(other range); ±3%RH(25°C,20%RH to 90%RH), ±5%RH(other range)	Report Generation	PDF&Excel report by Elitech software
Temperature Resolution	0.1°C,0.1%RH	Connection Interface	Mini USB
Shelf Life/Battery	1 years/CR2450 button cell	Data Storage Capacity	8000 readings (RC-4HA) 16,000 readings (RC-4HC)
Recording Interval	15 minutes(standard, others on request)	Password Protection	NONE
Stop Mode	Button, software or stop when full	Alarm Configuration	Optional, only 2 points
Dimensions	84mmx44mmx20mm(LxWxH)	Reprogrammable	With free Elitech Win or MAC software
Weight	35g	Startup Mode	Button
			1. Depending on optimal storage conditions (±15°C to +23°C/45% to 75% rH)

Elitech Technology, Inc.
www.elitechlog.com
1551 McCarthy Blvd, Suite 112
Milpitas, CA 95035 USA

V2.0



C.4 TD RTR-500-BW Network base station and RTR-576 Wireless CO2 logger

Network Base Station

RTR500BW Features and Specs

Data Transfer

Wireless LAN
Wired LAN

Data Monitoring

T&D WebStorage Service,
Internet / Intranet

Warnings

Set Limit Exceeded / Sensor Error /
Communication Error etc...

Warning Notification

E-mail / External
Contact Output

RTR500BW is a wireless data collector (base unit) with built-in wireless/wired LAN communication capabilities.

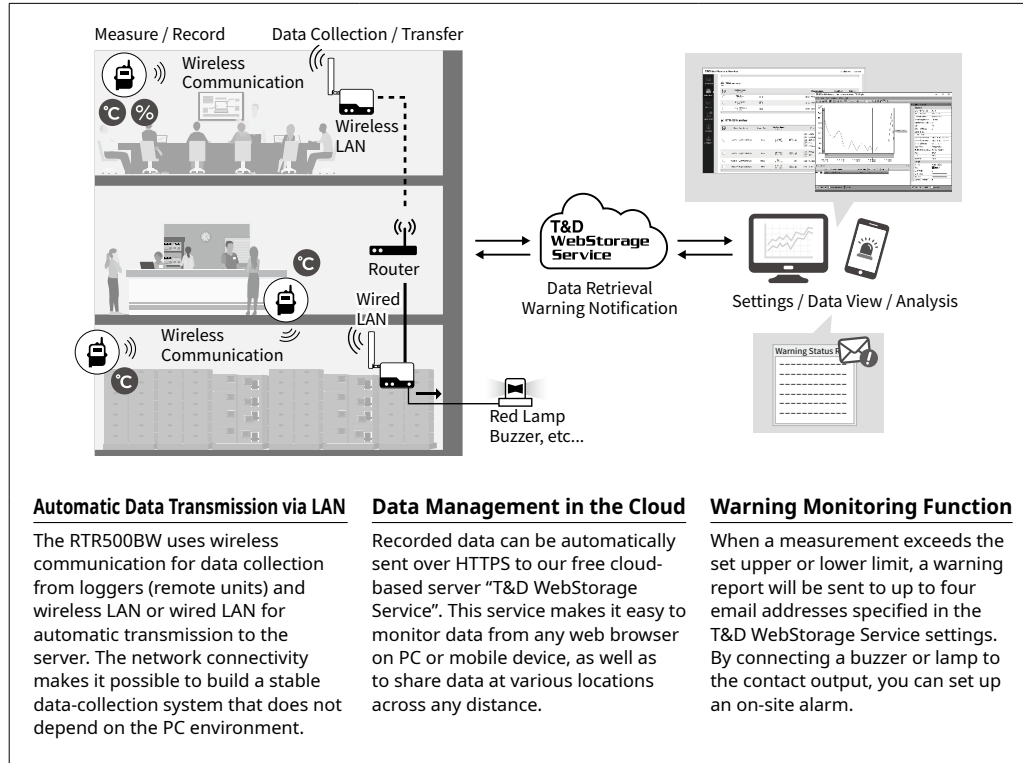

Initial Settings via Bluetooth® or USB

Initial settings can be made either on a mobile device using Bluetooth or on a PC using USB.

Remote Settings

By using our mobile app, it is also possible to make settings remotely over the cloud, such as the device name, recording interval, warning conditions, additional device registration, etc.

Extension Possible for Wireless Communication

The wireless communication range between a base and a remote unit, if unobstructed and direct, is about 150 meters (500 ft). This range can be extended by using a wireless repeater (RTR500BC).

Auto Wireless Route Settings

The most suitable route is automatically selected for wireless communication. This function makes installation simple and easy, even in a large-scale building that requires multiple repeaters.

Data Management on Intranet

You can set up a PC as a data destination by installing our free-of-charge "T&D Data Server" software. Functions such as saving received recorded data, monitoring and graph display with a web browser, and warning mail transmission are available even in environments where you cannot use the cloud service.

* Communication DLL specs for the RTR500B Series, as well as, file formats for Current Readings Files and Recorded Data Files (XML) are available free of charge to our customers. These allow you to integrate our products into your own applications and systems.



RTR500BW Specifications

RTR500BW	
Compatible Devices	Remote Units: RTR501B / 502B / 503B / 505B / 507B RTR-501 / 502 / 503 / 507S / 574 / 576 / 505-TC / 505-Pt / 505-V / 505-mA / 505-P (*1) (Including L Type and S Type) RTR-602S / 602L / 602ES / 602EL, RTR-601-110 / 601-130 / 601-E10 / 601-E30 (*1) Repeaters: RTR500BC RTR-500 (*1)
Maximum Number of Registrations	Remote Units: 50 units Repeaters: 10 units x 4 groups
Communication Interfaces	Short Range Wireless Communication <For US> Frequency Range: 902 to 928MHz RF Power: 7mW Transmission Range: About 150 meters (500 ft) if unobstructed and direct (*2) <For EU> Frequency Range: 869.7 to 870MHz RF Power: 5mW Transmission Range: About 150 meters (500 ft) if unobstructed and direct Wired LAN (RJ45 connector 100 Base-TX/10 Base-T) Wireless LAN (IEEE 802.11 a/b/g/n, WEP(64bit/128bit) / WPA-PSK(TKIP) / WPA2-PSK(AES)) Bluetooth 4.2 (Bluetooth Low Energy) For Settings USB 2.0 (Mini-B connector) For Settings Optical Communication (proprietary protocol)
Communication Time	Data Download Time (for 16,000 readings) Via wireless communication: About 2 minutes An additional 30 seconds should be added for each Repeater. (*3)
External Output Terminal	PhotoMOS Relay Output OFF-State Voltage: AC/DC 50V or less ON-State Current: 0.1 A or less ON-State Resistance: 35Ω
Communication Protocol (*4)	HTTP, HTTPS, FTP, SNMP, DHCP
Power	AC Adaptor (AD-05A4 or AD-05C1) PoE (IEEE 802.3af)
Dimensions	H 83 mm x W 102 mm x D 28 mm (excluding antenna) Antenna Length: 115 mm
Weight	Approx. 130 g
Operating Environment	Temperature: -10 to 60°C Humidity: 90%RH or less (without condensation)
Accessories	Antenna, USB Mini-B Cable US-15C, AC Adaptor AD-05A4 or AD-05C1, Registration Code Label, Manual Set (Warranty Included)

*1: RTR-500 Series loggers and Repeaters, as well as, RTR-600 Series loggers do not have Bluetooth capability.

*2: Transmission range between RTR500BW and RTR-600 Series loggers is about 50 meters.

*3: When using RTR500BC as Repeater. Depending upon conditions it may take up to an additional 2 minutes.

*4: Client Function. Communication via proxy is not supported.

The specifications listed above are subject to change without notice.



Wireless Data Logger

RTR500B Series Data Loggers Features and Specs

Measurement Items

Temp / Humidity / Voltage / 4-20mA /
Pulse Count / Illuminance / UV / CO2

Data Collection

Wireless Communication
with Data Collectors

The RTR500B Series includes data loggers designed to measure and record a wide variety of items as well as a range of base stations to enable wireless collection of recorded data.

Model	Measurement Items	Measurement Range	Notes
RTR501B / 501BL	Temperature 1ch (internal sensor)	-40 to 80°C	Gradual Response Time Optimum Waterproof and Dustproof Capabilities
RTR502B / 502BL	Temperature 1ch	-60 to 155°C	External Sensor for Quicker Response Time / Splash-proof Wide Selection of Optional Sensors
RTR503B / 503BL	Temperature / Humidity 1ch Each	0 to 55°C / 10 to 95%RH	Measure Temperature and Humidity
RTR507B / 507BL	Temperature / Humidity 1ch Each	-25 to 70°C / 0 to 99%RH	Measure Temperature and Humidity (High Precision)
RTR505B + TCM-3010	Temperature 1ch (Thermocouple)	-199 to 1760°C	For use with Thermocouple Sensor Types: K, J, T, S
RTR505B + PTM-3010	Temperature 1ch (Pt100, Pt1000)	-199 to 600°C	Supports 3-wire and 4-wire Sensors High Precision Measurement in Wide Temperature Range
RTR505B + VIM-3010	Voltage 1ch	DC 0 to 22V Min Resolution: 0.1mV	Preheat Function / Scale Conversion
RTR505B + AIM-3010	4-20mA 1ch	0 to 20 mA	Operational up to 40 mA / Scale Conversion
RTR505B + PIC-3150	Pulse Count 1ch	Pulse Count: 0 to 61439 Input Signal: Contact Input / Voltage Input	

* L-type models (model names which include "L") are designed with a large capacity battery pack. Battery life of the L type is four times longer than that of the normal type.

Model	Measurement Items	Measurement Range for Normal Type	Measurement Range for H Type	Notes
RTR-574 / 574-S	Illuminance UV Intensity Temperature Humidity 1ch each	0 to 130 klx 0 to 30 mW/cm2 0 to 55°C 10 to 95%RH	0 to 130 klx 0 to 30 mW/cm2 -25 to 70°C 0 to 99%RH	While recording possible to view cumulative illuminance and cumulative UV Possible to detect changes in illumiance even under moonlight
RTR-576 / 576-S	CO2 Concentration Temperature Humidity 1ch each	0 to 9,999 ppm 0 to 55°C 10 to 95%RH	0 to 9,999 ppm -25 to 70°C 0 to 99%RH	For measuring CO2 concentration in living environments. Auto Calibration Function

Collect Data via Wireless Communication with a Base Unit

Data loggers in our RTR500B Series function as Remote Units and need to be used with one of our collection devices (Base Unit).

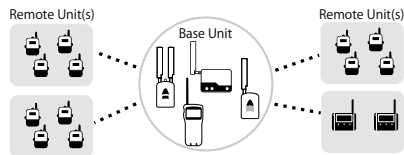

The collected data can then be transmitted to a PC, our free cloud service or your FTP server using a variety of methods such as USB, LAN and 3G network. Moreover, various functions, such as the monitoring of current readings and warning notification, make it a powerful data management system.

* Select a Base Unit according to the type and scale of the measuring environment.

Measure and Record Temperature and Humidity in a Wider Range with Greater Accuracy (RTR507B / RTR507BL / RTR-574-S / RTR-576-S)

The supplied sensor for the S-model provides higher accuracy to $\pm 2.5\%$ RH.

Measurement Range for temperature is -25 to 70°C and 0 to 99 %RH for humidity.



RTR-576 / 576-S Specifications

	RTR-576		RTR-576-S	
Temperature-Humidity Sensor				
Measurement Channels	Temperature 1ch	Humidity 1ch	Temperature 1ch	Humidity 1ch
Sensor	THA-3001		SHA-3151 High-Precision Type	
	Thermistor	Polymer Resistance	Thermistor	Polymer Resistance
Measurement Units	°C, °F	%RH	°C, °F	%RH
Measurement Range (*1)	0 to 55 °C	10 to 95%RH	-25 to 70 °C	0 to 99 %RH (*2)
Accuracy	±0.5 °C	5 %RH at 25 °C, 50 %RH	±0.3°C at 10 to 40 °C ±0.5°C all other temperatures	±2.5 %RH at 15 to 35 °C, 30 to 80 %RH
Measurement Resolution	0.1 °C	1 %RH	0.1 °C	0.1 %RH
Responsiveness	Response Time (90%): Approx. 7 min.		Response Time (90%): Approx. 7 min.	
CO2 Sensor (Internal)				
Measurement Channels	CO2 Concentration 1ch			
Sensor	NDIR			
Measurement Units	ppm			
Measurement Range	0 to 9,999 ppm			
Accuracy	±(50 ppm + 5% of reading) at 5,000 ppm or less (*3)			
Measurement Resolution	Minimum of 1 ppm			
Responsiveness	Response Time (90%): Approx. 1 min.			
Logging Capacity	8,000 data sets (One data set consists of readings for all channels in that type of unit.)			
Recording Interval	Select from 15 choices: 1, 2, 5, 10, 15, 20, 30 sec. or 1, 2, 5, 10, 15, 20, 30, 60 min.			
Recording Mode (*4)	Endless (Overwrite oldest data when capacity is full) or One Time (Stop recording when capacity is full)			
LCD Display Items	Measurements, Recording Status, Recording Mode, Battery Level, etc. Measurements: CO2 concentration, Temperature or Humidity (fixed or alternating display)			
Communication Interfaces	Short Range Wireless Communication <For US> Frequency Range: 902 to 928MHz RF Power: 7mW Transmission Range: About 150 meters (500 ft) if unobstructed and direct <For EU> Frequency Range: 869.7 to 870MHz RF Power: 5mW Transmission Range: About 150 meters if unobstructed and direct USB 2.0 (Mini-B connector) Serial Communication (*5)			
External Alarm Terminal (*6)	Output Terminal: Open Drain Output (Voltage when OFF: DC less than 30V / Current when ON: less than 0.1A / Resistance when ON: about 15Ω)			
Power	AC Adaptor AD-06A1 or AD-06C1, AA Alkaline Battery LR6 x 4			
Battery Life (*7)	Approx. 2 days (batteries only without AC adaptor)			
Dimensions	H 96 mm x W 66 mm x D 46 mm (excluding protrusions and sensor) Antenna Length: 60 mm			
Weight	Approx. 125 g			
Operating Environment	Temperature: 0 to 45°C Humidity: 90 %RH or less (no condensation)			
Accessories	AA Alkaline Battery LR6 x 4, AC Adaptor AD-06A1 or AD-06C1, USB Mini-B Cable US-15C, Temperature-Humidity Sensor THA-3001 or SHA-3151, Manual (Warranty Included)			
Compatible Base Units	RTR500BC, RTR500BW, RTR500BM RTR-500, RTR-500NW/500AW, RTR-500DC, RTR-500MBS-A			

*1: Make sure to use the data logger within the operating environment as listed in the specifications.

*2: When continually used in environments with temperatures above 60°C, accuracy of humidity measurements will decrease over time. Also, humidity cannot be measured at temperatures below -20°C.

*3: Stated value is the measurement accuracy of the CO2 sensor when Auto Calibration is operating properly. A change in atmospheric pressure directly influences the reading of CO2, which can cause measurement errors; a decrease in pressure by 10hPa results in a relative decrease in CO2 by 1.6%. In such a case, we recommend carrying out the "Atmospheric Pressure Correction" function found in the software for the Base Unit.

*4: Only "Endless" is available when using the RTR500BW, RTR500BM, RTR-500NW/AW or RTR-500MBS-A as a Base Unit.

*5: For communication with the Data Collector RTR-500DC (Note: Optional serial communication cable TR-6C10 is required.)

*6: In order to use the external alarm terminal, please purchase the optional alarm connection cable (AC0101).

*7: The listed battery life is based on the following usage conditions: Recording at 10 second (or longer) intervals, Current Readings Transmission every 10 minutes, and Recorded Data Transmission once a day. Battery life also varies depending on ambient temperature, radio environment, frequency of communication, etc.

The specifications listed above are subject to change without notice.



C.5 Monnit Wi-Fi Infrared Motion Sensor



Monnit Wi-Fi Infrared Motion Sensor



Technical Overview

General Description

The Monnit Wi-Fi Infrared Motion Sensor uses an infrared sensor to accurately detect movements made by people or large animals within 16.4 ft (5 m) range. An integrated 802.11 b/g radio allows the sensor to work with any existing Wi-Fi network. Monnit Wi-Fi sensors can be easily programmed with your Wi-Fi network's WEP or WPA(2) security via the free MoWi Setup Utility (PC application) and a MoWi USB programming cable (available in the [Monnit web store](#)).

Features

- Passive Infrared Technology.
- Sensing Range of 16.4 ft (5 m).
- Logs data if Wi-Fi network is disrupted.
- Free iMonnit basic online wireless sensor monitoring and notification system to configure sensors, view data and set alerts via SMS text and email.

Principle of Operation

The Monnit Wi-Fi Infrared Motion Sensor detects motion and movement using infrared technology. When the sensor detects movement it communicates with the iMonnit Online Sensor Monitoring and Notification System. iMonnit stores all data in the online system where the data can be reviewed and exported as a data sheet or graph. Notifications can be set up through the online system to alert the user when motion has been detected.

High Gain Antenna Option

Monnit Wi-Fi sensors are also available with a detachable high gain antenna to provide a 20-30% increase in range over the standard Wi-Fi sensor. Option uses a different hardware configuration and must be chosen at time of purchase.



Monnit Wi-Fi Sensor Electronics Specifications

- Power: 2 replaceable 1.5V "AA" batteries (included)
- Communication: 802.11 b/g
(2.412 - 2.484 GHz)
- Wi-Fi Security: Open, WEP, WPA, WPA2
- Dimensions: 3.02" x 2.1" x 1.27"
- Transmission Range: Up to 100 ft. *
- Battery Life: Up to 1 year.**

* Actual range may vary depending on environment.
** Battery life is affected by sensor usage, Wi-Fi security type, distance from Wi-Fi router, reporting frequency and other variables.

Height: 1.270 in (32.258 mm)

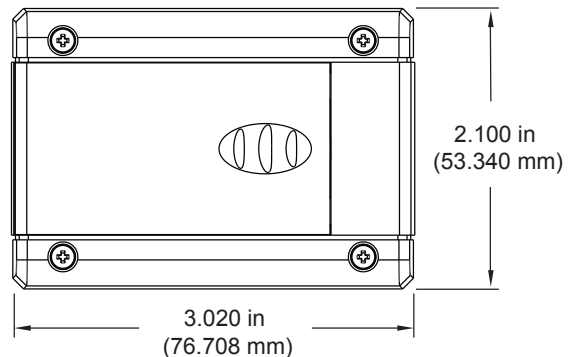

Applications

- Monitor area access.
- Detect when people enter a room.

The Leader in Low Cost Wireless Sensors

Technical Specifications	
Networking Standards	IEEE 802.11 b/g
Frequency Band	2.412 - 2.484 GHz
Wi-Fi Security Standards	Open, WEP, WPA, WPA2
Wi-Fi Security Programming	Via PC software using USB cable. (Can be changed through iMonnit online software.)
Network Settings	Auto DHCP/DNS or Static
Data Logging	Standard - On Wi-Fi disruption, unit will log the first 50 readings and transmit when Wi-Fi connection is re-established. Premiere - Unit can record up to 50,000 readings and transmit when Wi-Fi is available.
Power consumption	4uA sleep, 35mA active RX, 180mA TX (at +12dBm)
Battery Life	Up to 5 years depending on sensor type, Wi-Fi security, distance from Wi-Fi router, reporting frequency and other variables. (Testing surpassed 90,000 transmissions until battery depletion.)
Wi-Fi Data Rate	Auto configures to best rate for maximum range.
Wireless Range	Up to 100 ft. device range (typical to standard Wi-Fi devices).
Electronics Operating Temperature	Using Alkaline Batteries: -18°C to +55°C (0°F to +130°F) Using Lithium Batteries: -40°C to +85°C (-40°F to +185°F)
LED Light	Status / activity
Sensor Warmup Time	30 Seconds
Sensing Technology	Passive Infrared
Sensing Range	16.4 ft (5 m)
Certifications	 FCC ID: T9J-RN171. IC: RSS-210 low-power communication device. CE ID: 0681.

- * Hardware cannot withstand negative voltage. Please take care when connecting a power device.
- ** At temperatures above 100°C, it is possible for the board circuitry to lose programmed memory.

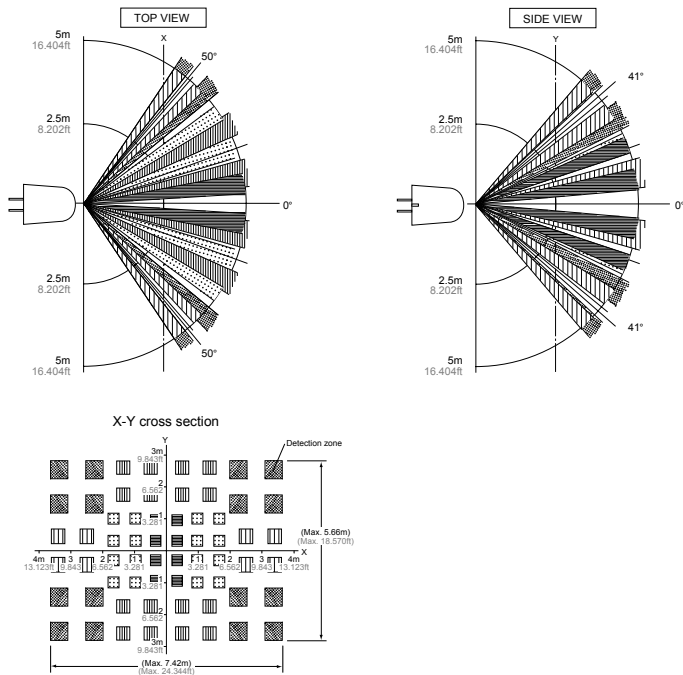

Remarks:

1. The X-Y cross-sectional diagram shows the detection area.
2. The differences in the detection zone patterns are indicative of the projections of the 16 lenses with single focal point and with five optical axes. An object whose temperature differs from the background temperature and which crosses inside the detection zone will be detected.



Monnit Corporation
 4403 South 500 West
 Murray, UT 84123
 801-561-5555
 www.monnit.com

For more information about our products or to place an order, please contact our sales department at 801-561-5555 or visit us on the web at www.monnit.com.

Appendix D: Experimental Data

As mentioned in Section 2.2, Table D.1 shows an overview of all the data collected during this study.

Table D.1: The time periods data collected and the number of recorded data samples available for each sensor.

Sensors	Data collection period(s)	Available sample data
T and D Wireless CO2 Recorder	July 1st, 2021 to October 26th, 2021 February 14th, 2022 to May 31st, 2022	254300
Omega WiFi Wireless Temperature and Humidity Data Loggers	July 1st, 2021 to April 14th, 2022	403670
Monnit Wi-Fi Infrared Motion Sensor	March 3rd, 2022 to May 31st, 2022	129600
Elitech RC-4HC Digital Temperature and Humidity Data Logger	April 14th, 2022 to May 3rd, 2022	27365

A sample of collected data on Mar 4th, 2022 is presented in Section D.1.

D.1 Sample of the experimental data

Date and Time	Office				Master bedroom		Foyer (Entrance)		Living room		
	Temperature (°C)	RH (%)	CO2 Concentration (ppm)	Motion Sensor status	Temperature (°C)	RH (%)	Temperature (°C)	RH (%)	Temperature (°C)	RH (%)	Motion Sensor status
2022-03-04 0:00	23.3	19	861	0	23.8	22	21.4	21	22.1	23	1
2022-03-04 0:01	23.3	20	860	0	23.7	22	21.3	21	22.1	23	1
2022-03-04 0:02	23.3	19	860	0	23.7	21	21.3	21	22.1	22	1
2022-03-04 0:03	23.3	20	855	0	23.7	21	21.3	21	22.1	22	1
2022-03-04 0:04	23.3	19	845	0	23.7	21	21.3	21	22.1	22	1
2022-03-04 0:05	23.3	19	832	0	23.7	21	21.3	21	22.1	22	0
2022-03-04 0:06	23.4	19	825	0	23.6	21	21.3	21	22.1	22	0
2022-03-04 0:07	23.4	19	821	0	23.7	21	21.3	21	22.1	22	0
2022-03-04 0:08	23.4	19	808	0	23.7	20	21.4	21	22.1	22	0
2022-03-04 0:09	23.5	19	792	0	23.7	21	21.4	21	22.1	22	0
2022-03-04 0:10	23.5	19	783	0	23.7	21	21.5	21	22.1	22	0
2022-03-04 0:11	23.6	18	776	0	23.7	21	21.5	21	22.2	22	0
2022-03-04 0:12	23.6	18	772	0	23.8	20	21.5	21	22.2	21	0
2022-03-04 0:13	23.7	18	763	0	23.8	20	21.6	21	22.2	21	0
2022-03-04 0:14	23.7	18	759	0	23.8	20	21.6	21	22.2	21	0
2022-03-04 0:15	23.7	18	750	0	23.9	20	21.7	21	22.3	21	0
2022-03-04 0:16	23.8	18	744	0	23.9	20	21.7	21	22.3	21	0
2022-03-04 0:17	23.8	18	736	0	23.9	20	21.7	21	22.3	22	0
2022-03-04 0:18	23.8	17	731	0	24	20	21.8	21	22.3	21	0
2022-03-04 0:19	23.9	17	728	0	24	20	21.8	21	22.4	22	0
2022-03-04 0:20	23.9	18	720	0	24	20	21.8	21	22.4	21	0
2022-03-04 0:21	23.9	18	715	0	24.1	20	21.9	21	22.4	22	0
2022-03-04 0:22	23.9	17	709	0	24.1	20	21.9	21	22.4	22	0
2022-03-04 0:23	23.9	17	705	0	24.2	20	21.9	21	22.4	22	0
2022-03-04 0:24	24	17	700	0	24.2	20	22	21	22.5	22	0
2022-03-04 0:25	24	17	696	0	24.3	20	22	21	22.5	22	0
2022-03-04 0:26	24	17	693	0	24.3	20	22.1	21	22.5	22	0
2022-03-04 0:27	24	17	690	0	24.3	21	22.1	21	22.6	22	0
2022-03-04 0:28	24	17	686	0	24.4	21	22.1	21	22.6	22	0
2022-03-04 0:29	24.1	17	680	0	24.4	21	22.2	21	22.6	22	0
2022-03-04 0:30	24.1	17	679	0	24.4	21	22.2	21	22.6	22	0
2022-03-04 0:31	24.1	17	675	0	24.5	21	22.3	21	22.7	22	0
2022-03-04 0:32	24.1	17	672	0	24.5	21	22.3	21	22.7	22	0
2022-03-04 0:33	24.1	17	670	0	24.5	21	22.3	21	22.7	22	0
2022-03-04 0:34	24.2	17	667	0	24.6	21	22.3	21	22.8	22	0
2022-03-04 0:35	24.2	17	664	0	24.6	21	22.4	21	22.8	22	0
2022-03-04 0:36	24.2	17	661	0	24.6	21	22.4	21	22.8	22	0
2022-03-04 0:37	24.2	17	660	0	24.7	21	22.5	21	22.9	22	0
2022-03-04 0:38	24.3	17	659	0	24.7	21	22.5	21	22.9	22	0
2022-03-04 0:39	24.3	17	655	0	24.7	21	22.5	21	22.9	22	0
2022-03-04 0:40	24.3	17	653	0	24.8	21	22.6	21	22.9	22	0
2022-03-04 0:41	24.3	17	651	0	24.8	21	22.6	21	23	22	0
2022-03-04 0:42	24.3	17	647	0	24.8	22	22.7	21	23	22	0
2022-03-04 0:43	24.3	17	648	0	24.8	22	22.7	21	23	22	0
2022-03-04 0:44	24.3	17	646	0	24.8	23	22.7	20	23	22	0
2022-03-04 0:45	24.2	17	647	0	24.8	23	22.8	20	23	22	0
2022-03-04 0:46	24.2	18	647	0	24.7	23	22.8	20	23	22	0
2022-03-04 0:47	24.1	17	645	0	24.7	24	22.8	21	23	22	0
2022-03-04 0:48	24	17	644	0	24.7	24	22.8	21	23	22	0
2022-03-04 0:49	24	18	642	0	24.6	25	22.8	21	23	22	0
2022-03-04 0:50	24	17	641	0	24.6	25	22.8	21	23	22	0
2022-03-04 0:51	23.9	17	641	0	24.6	26	22.8	21	23	22	0
2022-03-04 0:52	23.9	18	641	0	24.6	26	22.8	21	23	22	0
2022-03-04 0:53	23.9	18	641	0	24.5	26	22.8	21	23	22	0
2022-03-04 0:54	23.9	18	641	0	24.6	26	22.8	21	23	22	0
2022-03-04 0:55	23.9	18	640	0	24.5	26	22.8	21	23	22	0
2022-03-04 0:56	23.9	18	640	0	24.5	26	22.8	21	23	22	0
2022-03-04 0:57	23.8	17	639	0	24.5	26	22.8	21	23	22	0
2022-03-04 0:58	23.8	18	638	0	24.4	26	22.8	21	23	22	0
2022-03-04 0:59	23.8	18	637	0	24.4	26	22.8	21	23	22	0
2022-03-04 1:00	23.8	17	636	0	24.4	26	22.8	21	23	22	0
2022-03-04 1:01	23.8	18	636	0	24.4	26	22.8	21	22.9	22	0
2022-03-04 1:02	23.8	18	635	0	24.3	26	22.8	21	22.9	22	0
2022-03-04 1:03	23.7	18	636	0	24.3	27	22.8	21	22.9	22	0
2022-03-04 1:04	23.7	18	636	0	24.3	27	22.8	21	22.9	22	0
2022-03-04 1:05	23.7	18	636	0	24.3	27	22.8	21	22.9	22	0
2022-03-04 1:06	23.7	18	637	0	24.2	27	22.8	21	22.9	22	0
2022-03-04 1:07	23.7	18	637	0	24.2	27	22.8	21	22.9	22	0
2022-03-04 1:08	23.7	18	637	0	24.2	26	22.8	21	22.9	22	0
2022-03-04 1:09	23.6	18	637	0	24.2	25	22.8	21	22.9	22	0
2022-03-04 1:10	23.7	18	638	0	24.1	25	22.8	21	22.9	22	0
2022-03-04 1:11	23.7	18	637	0	24.1	24	22.8	21	22.9	22	0
2022-03-04 1:12	23.7	18	635	0	24.1	24	22.8	21	22.9	22	0
2022-03-04 1:13	23.8	18	630	0	24.1	24	22.8	21	22.9	22	0
2022-03-04 1:14	23.8	18	628	0	24.2	24	22.8	21	22.9	22	0
2022-03-04 1:15	23.9	18	626	0	24.2	24	22.8	20	22.9	22	0
2022-03-04 1:16	23.9	17	624	0	24.2	24	22.8	20	23	22	0
2022-03-04 1:17	23.9	17	622	0	24.3	24	22.9	20	23	22	0
2022-03-04 1:18	24	17	619	0	24.3	23	22.9	20	23	22	0
2022-03-04 1:19	24	17	617	0	24.3	23	22.9	20	23.1	22	0
2022-03-04 1:20	24	17	615	0	24.4	23	22.9	20	23.1	22	0
2022-03-04 1:21	24.1	17	615	0	24.4	23	23	20	23.1	22	0
2022-03-04 1:22	24.1	17	614	0	24.4	23	23	20	23.1	22	0
2022-03-04 1:23	24.2	17	613	0	24.5	23	23.1	20	23.1	22	0
2022-03-04 1:24	24.2	17	613	0	24.5	24	23.1	20	23.2	22	0
2022-03-04 1:25	24.2	17	611	0	24.5	25	23.1	20	23.2	22	0
2022-03-04 1:26	24.1	17	611	0	24.5	25	23.1	20	23.2	22	0
2022-03-04 1:27	24.1	17	611	0	24.5	26	23.1	20	23.2	22	0
2022-03-04 1:28	24	17	609	0	24.4	26	23.1	20	23.2	22	0
2022-03-04 1:29	24	17	609	0	24.4	26	23.1	20	23.2	22	0

Date and Time	Office				Master bedroom		Foyer (Entrance)		Living room		
	Temperature (°C)	RH (%)	CO2 Concentration (ppm)	Motion Sensor status	Temperature (°C)	RH (%)	Temperature (°C)	RH (%)	Temperature (°C)	RH (%)	Motion Sensor status
2022-03-04 1:30	23.9	17	608	0	24.4	26	23.1	20	23.2	22	0
2022-03-04 1:31	23.9	17	607	0	24.4	27	23.1	20	23.2	22	0
2022-03-04 1:32	23.9	18	607	0	24.3	27	23.1	20	23.2	22	0
2022-03-04 1:33	23.9	17	607	0	24.3	27	23.1	20	23.2	22	0
2022-03-04 1:34	23.9	17	607	0	24.3	28	23.1	20	23.2	22	0
2022-03-04 1:35	23.8	18	606	0	24.3	28	23.1	20	23.1	22	0
2022-03-04 1:36	23.8	17	605	0	24.2	28	23.1	20	23.1	22	0
2022-03-04 1:37	23.8	17	605	0	24.2	28	23.1	20	23.1	22	0
2022-03-04 1:38	23.8	17	605	0	24.2	28	23.1	20	23.1	22	0
2022-03-04 1:39	23.8	18	605	0	24.2	28	23.1	20	23.1	22	0
2022-03-04 1:40	23.7	17	602	0	24.2	28	23.1	20	23.1	22	0
2022-03-04 1:41	23.7	18	602	0	24.1	28	23.1	20	23.1	22	0
2022-03-04 1:42	23.7	18	602	0	24.1	28	23.1	20	23.1	22	0
2022-03-04 1:43	23.7	18	603	0	24.1	28	23.1	20	23.1	22	0
2022-03-04 1:44	23.7	17	604	0	24.1	28	23.1	20	23.1	22	0
2022-03-04 1:45	23.7	18	603	0	24	28	23.1	20	23.1	22	0
2022-03-04 1:46	23.6	17	603	0	24	28	23.1	20	23.1	22	0
2022-03-04 1:47	23.6	18	603	0	24	28	23.1	20	23.1	22	0
2022-03-04 1:48	23.6	18	604	0	24	28	23.1	20	23.1	22	0
2022-03-04 1:49	23.6	18	603	0	24	28	23.1	20	23.1	22	0
2022-03-04 1:50	23.6	18	603	0	23.9	29	23	20	23	22	0
2022-03-04 1:51	23.6	18	604	0	23.9	29	23	20	23	22	0
2022-03-04 1:52	23.6	18	605	0	23.9	29	23	20	23	22	0
2022-03-04 1:53	23.5	18	605	0	23.9	29	23	20	23	22	0
2022-03-04 1:54	23.5	18	606	0	23.9	29	23	20	23	22	0
2022-03-04 1:55	23.5	18	606	0	23.9	29	23	20	23	22	0
2022-03-04 1:56	23.5	18	606	0	23.9	29	23	20	23	22	0
2022-03-04 1:57	23.5	18	607	0	23.8	29	23	20	23	22	0
2022-03-04 1:58	23.5	18	606	0	23.8	29	23	20	23	22	0
2022-03-04 1:59	23.5	18	606	0	23.8	29	22.9	20	23	22	0
2022-03-04 2:00	23.5	18	606	0	23.8	29	22.9	20	23	22	0
2022-03-04 2:01	23.5	18	607	0	23.8	30	22.9	20	23	22	0
2022-03-04 2:02	23.5	18	608	0	23.7	30	22.9	20	23	22	0
2022-03-04 2:03	23.5	18	608	0	23.7	30	22.9	20	23	22	0
2022-03-04 2:04	23.5	18	607	0	23.7	30	22.9	20	22.9	22	0
2022-03-04 2:05	23.4	18	607	0	23.7	30	22.9	20	22.9	22	0
2022-03-04 2:06	23.4	18	607	0	23.7	30	22.9	20	22.9	22	0
2022-03-04 2:07	23.4	18	607	0	23.7	30	22.8	20	22.9	22	0
2022-03-04 2:08	23.4	18	607	0	23.6	31	22.8	20	22.9	22	0
2022-03-04 2:09	23.4	18	607	0	23.6	31	22.8	20	22.9	22	0
2022-03-04 2:10	23.4	18	607	0	23.6	30	22.8	20	22.9	22	0
2022-03-04 2:11	23.4	19	608	0	23.6	31	22.8	20	22.9	22	0
2022-03-04 2:12	23.4	18	608	0	23.6	31	22.8	20	22.9	22	0
2022-03-04 2:13	23.4	18	608	0	23.6	31	22.8	20	22.8	22	0
2022-03-04 2:14	23.4	19	609	0	23.6	31	22.8	20	22.8	22	0
2022-03-04 2:15	23.4	18	610	0	23.5	31	22.7	20	22.8	22	0
2022-03-04 2:16	23.4	18	610	0	23.5	31	22.7	20	22.8	22	0
2022-03-04 2:17	23.3	18	610	0	23.5	31	22.7	20	22.8	22	0
2022-03-04 2:18	23.3	18	611	0	23.5	31	22.7	20	22.8	22	0
2022-03-04 2:19	23.3	19	611	0	23.5	31	22.7	20	22.8	22	0
2022-03-04 2:20	23.3	19	611	0	23.5	31	22.7	20	22.8	22	0
2022-03-04 2:21	23.3	18	610	0	23.4	31	22.6	20	22.7	22	0
2022-03-04 2:22	23.3	19	611	0	23.4	31	22.6	20	22.7	22	0
2022-03-04 2:23	23.3	19	611	0	23.4	31	22.6	20	22.7	22	0
2022-03-04 2:24	23.3	18	612	0	23.4	31	22.6	19	22.7	22	0
2022-03-04 2:25	23.3	19	612	0	23.4	31	22.6	19	22.7	22	0
2022-03-04 2:26	23.3	18	613	0	23.4	31	22.6	19	22.7	22	0
2022-03-04 2:27	23.3	18	613	0	23.4	31	22.6	19	22.7	22	0
2022-03-04 2:28	23.3	18	612	0	23.4	31	22.5	19	22.7	22	0
2022-03-04 2:29	23.3	19	612	0	23.3	31	22.5	19	22.7	22	0
2022-03-04 2:30	23.2	19	612	0	23.3	32	22.5	19	22.7	22	0
2022-03-04 2:31	23.2	18	613	0	23.3	32	22.5	19	22.7	22	0
2022-03-04 2:32	23.2	19	612	0	23.3	32	22.5	19	22.6	22	0
2022-03-04 2:33	23.2	18	613	0	23.3	31	22.4	19	22.6	22	0
2022-03-04 2:34	23.2	18	613	0	23.3	32	22.4	19	22.6	22	0
2022-03-04 2:35	23.2	19	613	0	23.3	32	22.4	19	22.6	22	0
2022-03-04 2:36	23.2	19	612	0	23.3	31	22.4	20	22.6	22	0
2022-03-04 2:37	23.2	18	609	0	23.3	30	22.4	20	22.6	22	0
2022-03-04 2:38	23.2	18	605	0	23.3	29	22.4	20	22.6	21	0
2022-03-04 2:39	23.2	18	602	0	23.4	28	22.4	20	22.6	21	0
2022-03-04 2:40	23.3	18	601	0	23.5	28	22.4	20	22.6	21	0
2022-03-04 2:41	23.3	18	599	0	23.6	28	22.4	20	22.6	21	0
2022-03-04 2:42	23.4	18	595	0	23.6	27	22.4	20	22.6	21	0
2022-03-04 2:43	23.4	18	593	0	23.7	27	22.4	20	22.6	21	0
2022-03-04 2:44	23.5	17	591	0	23.8	27	22.4	20	22.6	21	0
2022-03-04 2:45	23.5	18	588	0	23.9	27	22.5	20	22.6	21	0
2022-03-04 2:46	23.6	18	586	0	24	27	22.5	20	22.6	21	0
2022-03-04 2:47	23.6	17	585	0	24.1	26	22.5	20	22.7	21	0
2022-03-04 2:48	23.7	17	584	0	24.2	26	22.6	20	22.7	21	0
2022-03-04 2:49	23.7	17	583	0	24.3	27	22.6	20	22.7	21	0
2022-03-04 2:50	23.7	17	583	0	24.3	27	22.6	20	22.7	21	0
2022-03-04 2:51	23.7	17	581	0	24.3	27	22.6	20	22.7	21	0
2022-03-04 2:52	23.6	17	581	0	24.4	27	22.6	20	22.7	21	0
2022-03-04 2:53	23.6	17	581	0	24.4	29	22.6	20	22.7	21	0
2022-03-04 2:54	23.6	17	580	0	24.4	29	22.6	20	22.7	21	0
2022-03-04 2:55	23.5	17	580	0	24.4	29	22.6	20	22.7	22	0
2022-03-04 2:56	23.5	17	579	0	24.4	30	22.6	20	22.7	22	0
2022-03-04 2:57	23.5	17	579	0	24.3	30	22.6	20	22.7	22	0
2022-03-04 2:58	23.5	17	578	0	24.3	30	22.6	20	22.7	22	0
2022-03-04 2:59	23.5	17	578	0	24.3	30	22.6	20	22.7	22	0

Date and Time	Office				Master bedroom		Foyer (Entrance)		Living room		
	Temperature (°C)	RH (%)	CO2 Concentration (ppm)	Motion Sensor status	Temperature (°C)	RH (%)	Temperature (°C)	RH (%)	Temperature (°C)	RH (%)	Motion Sensor status
2022-03-04 3:00	23.4	17	578	0	24.3	31	22.6	20	22.7	22	0
2022-03-04 3:01	23.4	17	577	0	24.3	31	22.6	20	22.7	22	0
2022-03-04 3:02	23.4	17	576	0	24.3	31	22.6	20	22.7	22	0
2022-03-04 3:03	23.4	17	576	0	24.3	31	22.6	20	22.7	22	0
2022-03-04 3:04	23.4	17	575	0	24.2	31	22.5	20	22.7	22	0
2022-03-04 3:05	23.3	17	575	0	24.2	31	22.5	20	22.6	22	0
2022-03-04 3:06	23.3	17	574	0	24.2	32	22.5	20	22.6	22	0
2022-03-04 3:07	23.3	17	574	0	24.2	32	22.5	20	22.6	22	0
2022-03-04 3:08	23.3	18	574	0	24.2	32	22.5	20	22.6	22	0
2022-03-04 3:09	23.2	17	575	0	24.1	32	22.5	20	22.6	22	0
2022-03-04 3:10	23.2	18	576	0	24.1	32	22.5	20	22.6	22	0
2022-03-04 3:11	23.2	18	575	0	24.1	32	22.5	20	22.6	22	0
2022-03-04 3:12	23.2	18	575	0	24.1	32	22.5	20	22.6	22	0
2022-03-04 3:13	23.2	18	576	0	24.1	32	22.5	20	22.6	22	0
2022-03-04 3:14	23.2	17	577	0	24.1	32	22.4	20	22.6	22	0
2022-03-04 3:15	23.2	18	576	0	24.1	33	22.4	20	22.6	22	0
2022-03-04 3:16	23.2	18	577	0	24.1	33	22.4	20	22.5	22	0
2022-03-04 3:17	23.2	18	578	0	24	33	22.4	20	22.5	22	0
2022-03-04 3:18	23.2	18	578	0	24	33	22.4	20	22.5	22	0
2022-03-04 3:19	23.2	18	578	0	24	33	22.4	20	22.5	22	0
2022-03-04 3:20	23.1	18	578	0	24	33	22.4	20	22.5	22	0
2022-03-04 3:21	23.1	18	578	0	24	33	22.3	20	22.5	22	0
2022-03-04 3:22	23.1	18	579	0	24	33	22.3	20	22.5	22	0
2022-03-04 3:23	23.1	18	579	0	24	33	22.3	20	22.5	22	0
2022-03-04 3:24	23.1	18	579	0	23.9	33	22.3	20	22.4	22	0
2022-03-04 3:25	23.1	18	579	0	23.9	33	22.3	19	22.4	22	0
2022-03-04 3:26	23.1	18	580	0	23.9	31	22.3	20	22.4	22	0
2022-03-04 3:27	23.1	18	579	0	23.9	30	22.3	20	22.4	22	0
2022-03-04 3:28	23.1	18	577	0	23.9	29	22.3	20	22.4	22	0
2022-03-04 3:29	23.1	18	577	0	23.9	28	22.3	20	22.4	21	0
2022-03-04 3:30	23.2	18	577	0	23.9	28	22.3	20	22.4	21	0
2022-03-04 3:31	23.2	17	575	0	23.9	28	22.3	20	22.4	21	0
2022-03-04 3:32	23.2	17	571	0	24	28	22.3	20	22.4	21	0
2022-03-04 3:33	23.3	17	569	0	24	27	22.3	20	22.4	21	0
2022-03-04 3:34	23.3	17	569	0	24	27	22.3	20	22.4	21	0
2022-03-04 3:35	23.4	17	568	0	24	27	22.3	20	22.4	21	0
2022-03-04 3:36	23.4	17	566	0	24.1	27	22.4	20	22.5	21	0
2022-03-04 3:37	23.5	17	566	0	24.1	26	22.4	20	22.5	21	0
2022-03-04 3:38	23.5	17	566	0	24.2	26	22.4	20	22.5	21	0
2022-03-04 3:39	23.6	17	565	0	24.2	27	22.5	20	22.5	21	0
2022-03-04 3:40	23.6	17	565	0	24.2	27	22.5	20	22.5	21	0
2022-03-04 3:41	23.5	17	565	0	24.2	29	22.5	20	22.5	21	0
2022-03-04 3:42	23.5	17	565	0	24.2	29	22.5	20	22.5	21	0
2022-03-04 3:43	23.5	17	565	0	24.2	29	22.5	20	22.5	21	0
2022-03-04 3:44	23.4	17	564	0	24.2	30	22.5	20	22.5	21	0
2022-03-04 3:45	23.4	17	563	0	24.2	30	22.5	20	22.5	22	0
2022-03-04 3:46	23.4	17	563	0	24.1	31	22.5	20	22.5	22	0
2022-03-04 3:47	23.4	17	563	0	24.1	31	22.5	20	22.5	22	0
2022-03-04 3:48	23.4	17	563	0	24.1	31	22.5	20	22.5	22	0
2022-03-04 3:49	23.3	17	563	0	24.1	31	22.5	20	22.5	22	0
2022-03-04 3:50	23.3	17	563	0	24.1	31	22.5	20	22.5	22	0
2022-03-04 3:51	23.3	17	562	0	24	32	22.5	20	22.5	22	0
2022-03-04 3:52	23.3	17	562	0	24	32	22.5	20	22.5	22	0
2022-03-04 3:53	23.3	17	562	0	24	32	22.4	20	22.5	22	0
2022-03-04 3:54	23.3	17	560	0	24	32	22.5	20	22.5	22	0
2022-03-04 3:55	23.2	17	560	0	24	33	22.4	20	22.5	22	0
2022-03-04 3:56	23.2	17	560	0	24	32	22.4	20	22.5	22	0
2022-03-04 3:57	23.2	17	562	0	24	33	22.4	20	22.5	22	0
2022-03-04 3:58	23.2	17	563	0	23.9	33	22.4	20	22.5	22	0
2022-03-04 3:59	23.1	17	562	0	23.9	33	22.4	20	22.5	22	0
2022-03-04 4:00	23.1	17	562	0	23.9	33	22.4	20	22.5	22	0
2022-03-04 4:01	23.1	17	561	0	23.9	33	22.4	20	22.5	22	0
2022-03-04 4:02	23.1	18	562	0	23.9	33	22.4	20	22.4	22	0
2022-03-04 4:03	23.1	18	569	0	23.8	33	22.4	20	22.4	22	0
2022-03-04 4:04	23.1	18	579	0	23.8	33	22.4	20	22.4	22	0
2022-03-04 4:05	23.1	18	585	0	23.8	34	22.3	20	22.4	22	0
2022-03-04 4:06	23.1	18	588	0	23.8	34	22.3	20	22.4	22	0
2022-03-04 4:07	23.1	18	593	0	23.8	34	22.3	20	22.4	22	0
2022-03-04 4:08	23.1	18	595	0	23.8	34	22.3	20	22.4	22	0
2022-03-04 4:09	23.1	18	597	0	23.7	34	22.3	20	22.4	22	0
2022-03-04 4:10	23.1	18	599	0	23.7	34	22.3	20	22.4	22	0
2022-03-04 4:11	23.1	18	601	0	23.7	35	22.3	20	22.4	22	0
2022-03-04 4:12	23.1	18	604	0	23.7	32	22.3	20	22.4	22	0
2022-03-04 4:13	23.1	18	606	0	23.7	31	22.3	20	22.3	22	0
2022-03-04 4:14	23.1	18	607	0	23.7	30	22.3	20	22.3	22	0
2022-03-04 4:15	23.2	18	605	0	23.7	29	22.3	20	22.3	21	0
2022-03-04 4:16	23.2	18	605	0	23.7	29	22.3	20	22.3	21	0
2022-03-04 4:17	23.3	18	606	0	23.7	29	22.3	20	22.3	21	0
2022-03-04 4:18	23.3	18	607	0	23.7	29	22.3	20	22.3	21	0
2022-03-04 4:19	23.3	17	607	0	23.7	28	22.3	20	22.3	21	0
2022-03-04 4:20	23.4	18	606	0	23.8	28	22.3	20	22.4	21	0
2022-03-04 4:21	23.4	17	602	0	23.8	28	22.3	20	22.4	21	0
2022-03-04 4:22	23.5	17	597	0	23.9	28	22.4	20	22.4	21	0
2022-03-04 4:23	23.5	17	592	0	23.9	28	22.4	20	22.4	21	0
2022-03-04 4:24	23.5	17	590	0	23.9	27	22.4	20	22.4	21	0
2022-03-04 4:25	23.6	17	587	0	24	27	22.4	20	22.5	21	0
2022-03-04 4:26	23.6	17	585	0	24	27	22.5	20	22.5	21	0
2022-03-04 4:27	23.7	17	585	0	24.1	27	22.5	20	22.5	21	0
2022-03-04 4:28	23.7	17	584	0	24.1	28	22.5	20	22.5	22	0
2022-03-04 4:29	23.7	17	583	0	24.1	29	22.5	20	22.5	22	0

Date and Time	Office				Master bedroom		Foyer (Entrance)		Living room		
	Temperature (°C)	RH (%)	CO2 Concentration (ppm)	Motion Sensor status	Temperature (°C)	RH (%)	Temperature (°C)	RH (%)	Temperature (°C)	RH (%)	Motion Sensor status
2022-03-04 4:30	23.7	17	582	0	24.1	30	22.5	20	22.5	22	0
2022-03-04 4:31	23.6	17	582	0	24	31	22.5	20	22.5	22	0
2022-03-04 4:32	23.6	17	580	0	24	31	22.5	20	22.5	22	0
2022-03-04 4:33	23.6	17	577	0	24	31	22.5	20	22.5	22	0
2022-03-04 4:34	23.6	17	575	0	24	32	22.5	20	22.5	22	0
2022-03-04 4:35	23.5	17	572	0	24	32	22.5	20	22.5	22	0
2022-03-04 4:36	23.5	16	571	0	23.9	33	22.5	20	22.5	22	0
2022-03-04 4:37	23.4	17	572	0	23.9	33	22.5	20	22.5	22	0
2022-03-04 4:38	23.4	17	571	0	23.9	33	22.5	20	22.5	22	0
2022-03-04 4:39	23.4	17	571	0	23.9	33	22.5	20	22.5	22	0
2022-03-04 4:40	23.4	16	571	0	23.9	33	22.5	20	22.5	22	0
2022-03-04 4:41	23.4	16	570	0	23.9	33	22.5	20	22.5	22	0
2022-03-04 4:42	23.3	17	570	0	23.8	33	22.5	20	22.5	22	0
2022-03-04 4:43	23.3	17	570	0	23.8	34	22.5	20	22.5	22	0
2022-03-04 4:44	23.3	17	570	0	23.8	34	22.5	20	22.5	22	0
2022-03-04 4:45	23.3	17	571	0	23.8	34	22.5	20	22.4	22	0
2022-03-04 4:46	23.3	17	571	0	23.7	34	22.5	20	22.4	22	0
2022-03-04 4:47	23.3	17	571	0	23.7	34	22.5	20	22.4	22	0
2022-03-04 4:48	23.3	17	572	0	23.7	34	22.5	20	22.4	22	0
2022-03-04 4:49	23.3	17	572	0	23.7	34	22.5	20	22.4	22	0
2022-03-04 4:50	23.3	17	572	0	23.7	34	22.5	20	22.4	22	0
2022-03-04 4:51	23.3	17	571	0	23.7	34	22.4	20	22.4	22	0
2022-03-04 4:52	23.3	17	571	0	23.6	34	22.4	20	22.4	22	0
2022-03-04 4:53	23.3	17	570	0	23.6	34	22.4	20	22.4	22	0
2022-03-04 4:54	23.3	17	570	0	23.6	34	22.4	20	22.4	22	0
2022-03-04 4:55	23.3	17	569	0	23.6	35	22.4	20	22.4	22	0
2022-03-04 4:56	23.2	17	568	0	23.6	35	22.4	20	22.4	22	0
2022-03-04 4:57	23.2	17	569	0	23.6	35	22.4	20	22.4	22	0
2022-03-04 4:58	23.2	17	569	0	23.6	35	22.4	20	22.4	22	0
2022-03-04 4:59	23.2	17	569	0	23.5	35	22.4	20	22.4	22	0
2022-03-04 5:00	23.2	18	569	0	23.5	35	22.3	20	22.4	22	0
2022-03-04 5:01	23.2	18	568	0	23.5	35	22.3	20	22.3	22	0
2022-03-04 5:02	23.2	17	568	0	23.5	35	22.3	20	22.3	22	0
2022-03-04 5:03	23.2	17	569	0	23.5	35	22.3	20	22.3	22	0
2022-03-04 5:04	23.2	17	568	0	23.5	33	22.3	20	22.3	22	0
2022-03-04 5:05	23.2	17	567	0	23.4	32	22.3	20	22.3	22	0
2022-03-04 5:06	23.2	17	566	0	23.4	31	22.3	20	22.3	22	0
2022-03-04 5:07	23.2	17	564	0	23.4	31	22.3	20	22.3	22	0
2022-03-04 5:08	23.2	17	562	0	23.4	31	22.3	20	22.3	21	0
2022-03-04 5:09	23.3	17	561	0	23.4	30	22.3	20	22.3	21	0
2022-03-04 5:10	23.3	17	562	0	23.5	30	22.3	20	22.3	21	0
2022-03-04 5:11	23.3	17	561	0	23.5	30	22.3	20	22.3	21	0
2022-03-04 5:12	23.4	17	560	0	23.6	29	22.3	20	22.3	21	0
2022-03-04 5:13	23.4	17	558	0	23.6	29	22.3	20	22.3	21	0
2022-03-04 5:14	23.5	17	558	0	23.7	29	22.3	20	22.4	21	0
2022-03-04 5:15	23.5	16	558	0	23.7	29	22.4	20	22.4	21	0
2022-03-04 5:16	23.6	16	558	0	23.7	28	22.4	20	22.4	21	0
2022-03-04 5:17	23.6	16	558	0	23.8	28	22.4	20	22.4	21	0
2022-03-04 5:18	23.6	17	558	0	23.8	29	22.4	20	22.5	22	0
2022-03-04 5:19	23.7	16	558	0	23.8	30	22.5	20	22.5	22	0
2022-03-04 5:20	23.7	17	559	0	23.8	31	22.5	20	22.5	22	0
2022-03-04 5:21	23.7	16	560	0	23.8	31	22.5	20	22.5	22	0
2022-03-04 5:22	23.6	16	560	0	23.8	32	22.5	20	22.5	22	0
2022-03-04 5:23	23.6	17	560	0	23.8	32	22.5	20	22.5	22	0
2022-03-04 5:24	23.6	17	560	0	23.8	33	22.5	20	22.4	22	0
2022-03-04 5:25	23.5	16	560	0	23.7	33	22.5	20	22.4	22	0
2022-03-04 5:26	23.5	16	559	0	23.7	33	22.5	20	22.4	22	0
2022-03-04 5:27	23.5	16	558	0	23.7	34	22.5	20	22.4	22	0
2022-03-04 5:28	23.4	16	557	0	23.7	34	22.5	20	22.4	22	0
2022-03-04 5:29	23.4	16	557	0	23.7	33	22.5	20	22.4	22	0
2022-03-04 5:30	23.4	17	557	0	23.6	34	22.5	20	22.4	22	0
2022-03-04 5:31	23.4	16	557	0	23.6	34	22.5	20	22.4	22	0
2022-03-04 5:32	23.3	16	556	0	23.6	34	22.5	20	22.4	22	0
2022-03-04 5:33	23.3	17	556	0	23.6	34	22.4	20	22.4	22	0
2022-03-04 5:34	23.3	17	557	0	23.6	34	22.4	20	22.4	22	0
2022-03-04 5:35	23.3	17	557	0	23.5	34	22.4	20	22.4	22	0
2022-03-04 5:36	23.3	17	557	0	23.5	34	22.4	20	22.4	22	0
2022-03-04 5:37	23.2	17	557	0	23.5	34	22.4	20	22.4	22	0
2022-03-04 5:38	23.2	16	557	0	23.5	34	22.4	20	22.4	22	0
2022-03-04 5:39	23.2	17	557	0	23.5	34	22.4	20	22.4	22	0
2022-03-04 5:40	23.2	17	557	0	23.5	34	22.4	20	22.4	22	0
2022-03-04 5:41	23.2	17	557	0	23.5	34	22.4	20	22.4	22	0
2022-03-04 5:42	23.2	17	558	0	23.4	35	22.4	20	22.3	22	0
2022-03-04 5:43	23.2	17	558	0	23.4	35	22.4	20	22.3	22	0
2022-03-04 5:44	23.1	17	558	0	23.4	35	22.4	20	22.3	22	0
2022-03-04 5:45	23.1	17	559	0	23.4	35	22.3	20	22.3	22	0
2022-03-04 5:46	23.1	17	560	0	23.4	35	22.3	20	22.3	22	0
2022-03-04 5:47	23.1	17	559	0	23.4	35	22.3	20	22.3	22	0
2022-03-04 5:48	23.1	17	559	0	23.4	35	22.3	20	22.3	22	0
2022-03-04 5:49	23.1	17	559	0	23.3	35	22.3	20	22.3	22	0
2022-03-04 5:50	23.1	17	559	0	23.3	35	22.3	20	22.3	22	0
2022-03-04 5:51	23.1	17	560	0	23.3	35	22.3	20	22.3	22	0
2022-03-04 5:52	23.1	17	560	0	23.3	33	22.3	20	22.3	22	0
2022-03-04 5:53	23.1	17	561	0	23.3	32	22.3	20	22.3	22	0
2022-03-04 5:54	23.1	17	560	0	23.2	31	22.3	20	22.3	22	0
2022-03-04 5:55	23.1	17	558	0	23.2	31	22.3	20	22.2	22	0
2022-03-04 5:56	23.1	17	558	0	23.3	31	22.3	20	22.2	21	0
2022-03-04 5:57	23.2	17	557	0	23.3	31	22.3	20	22.2	21	0
2022-03-04 5:58	23.2	17	556	0	23.3	30	22.3	20	22.3	21	0
2022-03-04 5:59	23.3	17	557	0	23.3	30	22.3	20	22.3	21	0

Date and Time	Office				Master bedroom		Foyer (Entrance)		Living room		
	Temperature (°C)	RH (%)	CO2 Concentration (ppm)	Motion Sensor status	Temperature (°C)	RH (%)	Temperature (°C)	RH (%)	Temperature (°C)	RH (%)	Motion Sensor status
2022-03-04 6:00	23.3	17	556	0	23.4	29	22.3	20	22.3	21	0
2022-03-04 6:01	23.4	17	556	0	23.4	29	22.3	20	22.3	21	0
2022-03-04 6:02	23.4	17	556	0	23.4	29	22.3	20	22.4	21	0
2022-03-04 6:03	23.5	16	555	0	23.5	29	22.4	20	22.4	21	0
2022-03-04 6:04	23.5	17	555	0	23.5	29	22.4	20	22.4	21	0
2022-03-04 6:05	23.5	17	555	0	23.6	28	22.4	20	22.4	21	0
2022-03-04 6:06	23.5	17	554	0	23.6	29	22.5	20	22.4	22	0
2022-03-04 6:07	23.6	16	554	0	23.6	30	22.5	20	22.4	22	0
2022-03-04 6:08	23.5	17	555	0	23.6	31	22.5	20	22.4	22	0
2022-03-04 6:09	23.5	17	555	0	23.6	32	22.5	20	22.4	22	0
2022-03-04 6:10	23.4	17	555	0	23.6	32	22.5	20	22.4	22	0
2022-03-04 6:11	23.4	17	556	0	23.6	33	22.5	20	22.4	22	0
2022-03-04 6:12	23.4	16	556	0	23.6	33	22.5	20	22.4	22	0
2022-03-04 6:13	23.3	17	556	0	23.5	33	22.5	20	22.4	22	0
2022-03-04 6:14	23.3	16	555	0	23.5	34	22.5	20	22.4	22	0
2022-03-04 6:15	23.3	17	556	0	23.5	34	22.5	20	22.4	22	0
2022-03-04 6:16	23.3	17	555	0	23.5	34	22.5	20	22.4	22	0
2022-03-04 6:17	23.3	17	555	0	23.5	34	22.5	20	22.4	22	0
2022-03-04 6:18	23.2	16	555	0	23.4	34	22.5	20	22.4	22	0
2022-03-04 6:19	23.2	17	555	0	23.4	34	22.5	20	22.4	22	0
2022-03-04 6:20	23.2	17	555	0	23.4	34	22.5	20	22.4	22	0
2022-03-04 6:21	23.2	16	555	0	23.4	34	22.5	20	22.4	22	0
2022-03-04 6:22	23.2	16	556	0	23.4	34	22.5	20	22.4	22	0
2022-03-04 6:23	23.1	17	557	0	23.4	34	22.4	20	22.4	22	0
2022-03-04 6:24	23.1	17	558	0	23.3	34	22.4	20	22.4	22	0
2022-03-04 6:25	23.1	17	558	0	23.3	34	22.4	20	22.4	22	0
2022-03-04 6:26	23.1	17	559	0	23.3	34	22.4	20	22.4	22	0
2022-03-04 6:27	23.1	17	559	0	23.3	34	22.4	20	22.4	22	0
2022-03-04 6:28	23.1	17	560	0	23.3	34	22.4	20	22.3	22	0
2022-03-04 6:29	23	17	560	0	23.3	35	22.4	20	22.3	22	0
2022-03-04 6:30	23	17	560	0	23.2	35	22.4	20	22.3	22	0
2022-03-04 6:31	23	17	561	0	23.2	34	22.4	20	22.3	22	0
2022-03-04 6:32	23	17	562	0	23.2	33	22.4	20	22.3	22	0
2022-03-04 6:33	23	17	562	0	23.2	32	22.4	20	22.3	22	0
2022-03-04 6:34	23	17	561	0	23.2	31	22.4	20	22.3	22	0
2022-03-04 6:35	23.1	17	562	0	23.2	31	22.4	20	22.3	22	0
2022-03-04 6:36	23.1	17	561	0	23.2	31	22.4	20	22.3	22	0
2022-03-04 6:37	23.1	17	561	0	23.2	30	22.4	20	22.3	22	0
2022-03-04 6:38	23.2	17	561	0	23.2	30	22.4	20	22.3	22	0
2022-03-04 6:39	23.2	17	560	0	23.3	30	22.4	20	22.3	22	0
2022-03-04 6:40	23.3	17	559	0	23.3	29	22.4	20	22.4	22	0
2022-03-04 6:41	23.3	17	559	0	23.4	29	22.5	20	22.4	22	0
2022-03-04 6:42	23.4	17	559	0	23.4	29	22.5	20	22.4	22	0
2022-03-04 6:43	23.4	17	559	0	23.4	29	22.5	20	22.4	22	0
2022-03-04 6:44	23.5	16	559	0	23.5	28	22.6	20	22.5	22	0
2022-03-04 6:45	23.5	16	559	0	23.5	28	22.6	20	22.5	22	0
2022-03-04 6:46	23.5	16	558	0	23.6	28	22.6	20	22.5	22	0
2022-03-04 6:47	23.5	16	558	0	23.6	28	22.6	20	22.6	22	0
2022-03-04 6:48	23.6	16	559	0	23.7	28	22.7	20	22.6	22	0
2022-03-04 6:49	23.6	16	559	0	23.7	28	22.7	20	22.6	22	0
2022-03-04 6:50	23.6	16	560	0	23.7	27	22.7	20	22.7	22	0
2022-03-04 6:51	23.7	16	560	0	23.8	27	22.8	20	22.7	22	0
2022-03-04 6:52	23.7	17	560	0	23.8	27	22.8	20	22.7	22	0
2022-03-04 6:53	23.7	16	560	0	23.9	27	22.8	20	22.7	22	0
2022-03-04 6:54	23.7	16	561	0	23.9	27	22.8	20	22.8	22	0
2022-03-04 6:55	23.7	16	561	0	24	27	22.9	20	22.8	22	0
2022-03-04 6:56	23.8	17	562	0	24	27	22.9	20	22.8	22	0
2022-03-04 6:57	23.8	17	563	0	24.1	27	23	20	22.9	22	0
2022-03-04 6:58	23.8	16	563	0	24.1	27	23	20	22.9	22	0
2022-03-04 6:59	23.8	16	564	0	24.1	27	23	20	22.9	22	0
2022-03-04 7:00	23.9	16	564	0	24.2	27	23.1	20	23	22	0
2022-03-04 7:01	23.9	17	565	0	24.2	27	23.1	20	23	22	0
2022-03-04 7:02	23.8	17	566	0	24.2	29	23.1	20	23	22	0
2022-03-04 7:03	23.8	16	565	0	24.1	29	23.2	20	23	22	0
2022-03-04 7:04	23.8	17	565	0	24.1	30	23.2	20	23	22	0
2022-03-04 7:05	23.7	17	565	0	24.1	30	23.2	20	23	22	0
2022-03-04 7:06	23.7	17	564	0	24.1	30	23.2	20	23	22	0
2022-03-04 7:07	23.6	17	565	0	24	31	23.2	20	23	22	0
2022-03-04 7:08	23.6	16	565	0	24	31	23.2	20	23	22	0
2022-03-04 7:09	23.6	17	565	0	24	32	23.2	20	23	22	0
2022-03-04 7:10	23.5	17	565	0	24	32	23.2	20	23	22	0
2022-03-04 7:11	23.5	17	566	0	23.9	32	23.2	20	23	22	0
2022-03-04 7:12	23.5	17	566	0	24	33	23.2	20	22.9	22	0
2022-03-04 7:13	23.4	17	565	0	24	33	23.2	20	22.9	22	0
2022-03-04 7:14	23.4	17	565	0	23.9	33	23.2	20	22.9	22	0
2022-03-04 7:15	23.4	17	567	0	23.9	34	23.2	20	22.9	22	0
2022-03-04 7:16	23.4	17	568	0	23.9	34	23.2	20	22.9	22	0
2022-03-04 7:17	23.4	17	567	0	23.9	34	23.2	20	22.9	22	0
2022-03-04 7:18	23.4	17	567	0	23.8	33	23.2	20	22.9	22	0
2022-03-04 7:19	23.4	17	566	0	23.8	33	23.2	20	22.9	22	0
2022-03-04 7:20	23.4	17	566	0	23.8	33	23.2	20	22.9	22	0
2022-03-04 7:21	23.3	17	567	0	23.8	33	23.2	20	22.9	22	0
2022-03-04 7:22	23.3	17	568	0	23.8	33	23.2	20	22.9	22	0
2022-03-04 7:23	23.3	17	569	0	23.8	33	23.2	20	22.9	22	0
2022-03-04 7:24	23.3	17	569	0	23.8	33	23.2	20	22.9	22	0
2022-03-04 7:25	23.3	17	569	0	23.8	33	23.2	20	22.9	22	0
2022-03-04 7:26	23.3	17	569	0	23.8	33	23.2	20	22.9	22	0
2022-03-04 7:27	23.3	17	570	0	23.8	34	23.2	20	22.9	22	0
2022-03-04 7:28	23.3	17	570	0	23.9	35	23.2	20	22.9	22	0
2022-03-04 7:29	23.3	17	571	0	23.9	33	23.1	20	22.9	22	0

Date and Time	Office				Master bedroom		Foyer (Entrance)		Living room		
	Temperature (°C)	RH (%)	CO2 Concentration (ppm)	Motion Sensor status	Temperature (°C)	RH (%)	Temperature (°C)	RH (%)	Temperature (°C)	RH (%)	Motion Sensor status
2022-03-04 7:30	23.3	17	571	0	23.9	31	23.1	20	22.9	22	0
2022-03-04 7:31	23.3	17	572	0	23.9	30	23.1	20	22.9	22	0
2022-03-04 7:32	23.3	17	572	0	23.9	30	23.1	20	22.9	22	0
2022-03-04 7:33	23.3	17	572	0	23.9	30	23.1	20	22.9	22	0
2022-03-04 7:34	23.4	17	570	0	23.9	30	23.1	20	22.9	22	0
2022-03-04 7:35	23.4	17	567	0	23.9	29	23.1	20	22.9	22	0
2022-03-04 7:36	23.5	17	566	0	24	29	23.1	20	22.9	22	0
2022-03-04 7:37	23.5	17	565	0	24	29	23.2	20	22.9	22	0
2022-03-04 7:38	23.6	17	564	0	24	28	23.2	20	23	22	0
2022-03-04 7:39	23.6	17	564	0	24.1	28	23.2	20	23	22	0
2022-03-04 7:40	23.6	17	563	0	24.1	28	23.2	20	23	22	0
2022-03-04 7:41	23.7	17	563	0	24.2	28	23.2	20	23	22	0
2022-03-04 7:42	23.7	16	563	0	24.2	28	23.2	20	23	22	0
2022-03-04 7:43	23.7	16	563	0	24.3	27	23.3	20	23.1	22	0
2022-03-04 7:44	23.8	16	563	0	24.3	27	23.3	20	23.1	22	1
2022-03-04 7:45	23.8	16	563	0	24.3	28	23.3	20	23.1	22	1
2022-03-04 7:46	23.8	17	563	0	24.3	28	23.4	20	23.2	22	1
2022-03-04 7:47	23.8	17	563	0	24.3	30	23.4	20	23.2	22	1
2022-03-04 7:48	23.7	17	564	0	24.3	30	23.4	20	23.2	22	1
2022-03-04 7:49	23.7	17	564	0	24.3	31	23.4	20	23.2	22	1
2022-03-04 7:50	23.7	17	564	0	24.3	31	23.4	20	23.2	22	1
2022-03-04 7:51	23.6	17	564	0	24.3	31	23.4	20	23.2	22	1
2022-03-04 7:52	23.6	17	563	0	24.2	31	23.4	20	23.2	22	1
2022-03-04 7:53	23.5	17	563	0	24.2	32	23.4	20	23.2	22	1
2022-03-04 7:54	23.5	17	563	0	24.2	32	23.4	20	23.2	22	1
2022-03-04 7:55	23.5	17	563	0	24.2	32	23.4	20	23.1	22	1
2022-03-04 7:56	23.5	17	564	0	24.1	32	23.4	20	23.1	22	1
2022-03-04 7:57	23.5	17	564	0	24.1	32	23.4	20	23.1	22	1
2022-03-04 7:58	23.4	17	564	0	24.1	33	23.5	20	23.1	22	1
2022-03-04 7:59	23.4	17	564	0	24.1	32	23.5	20	23.1	22	1
2022-03-04 8:00	23.4	17	562	0	24.1	32	23.5	20	23.1	22	1
2022-03-04 8:01	23.4	17	561	0	24.1	33	23.5	20	23.1	22	1
2022-03-04 8:02	23.4	17	561	0	24	33	23.5	20	23.1	23	1
2022-03-04 8:03	23.4	17	561	0	24	32	23.5	20	23.1	23	1
2022-03-04 8:04	23.3	17	561	0	24	33	23.5	20	23.1	23	1
2022-03-04 8:05	23.3	17	562	0	24	33	23.4	20	23.1	23	1
2022-03-04 8:06	23.3	17	563	0	24	33	23.4	20	23.1	23	1
2022-03-04 8:07	23.3	17	563	0	23.9	33	23.4	20	23.1	23	1
2022-03-04 8:08	23.3	17	564	0	23.9	33	23.4	20	23.1	23	1
2022-03-04 8:09	23.3	17	564	0	23.9	33	23.4	20	23.1	23	1
2022-03-04 8:10	23.3	17	565	0	23.9	34	23.4	20	23.1	23	1
2022-03-04 8:11	23.2	17	564	0	23.9	34	23.4	20	23.1	23	1
2022-03-04 8:12	23.2	17	564	0	23.8	34	23.4	20	23.1	23	1
2022-03-04 8:13	23.2	17	565	0	23.8	34	23.4	20	23.1	23	1
2022-03-04 8:14	23.2	17	565	0	23.8	34	23.4	20	23.1	23	1
2022-03-04 8:15	23.2	17	565	0	23.8	34	23.4	20	23	23	1
2022-03-04 8:16	23.2	17	566	0	23.8	35	23.4	20	23.1	23	1
2022-03-04 8:17	23.2	17	566	0	23.7	35	23.4	20	23	23	1
2022-03-04 8:18	23.2	17	566	0	23.7	36	23.4	20	23	23	1
2022-03-04 8:19	23.2	17	566	0	23.7	36	23.3	20	23	23	1
2022-03-04 8:20	23.2	17	567	1	23.7	35	23.3	20	23	23	1
2022-03-04 8:21	23.2	17	569	1	23.7	35	23.3	20	23	23	1
2022-03-04 8:22	23.2	18	570	1	23.7	35	23.3	20	23	23	1
2022-03-04 8:23	23.2	18	572	0	23.6	35	23.3	20	23	23	1
2022-03-04 8:24	23.2	18	581	0	23.6	35	23.3	20	23	23	1
2022-03-04 8:25	23.2	18	599	0	23.6	35	23.3	20	23	23	1
2022-03-04 8:26	23.2	18	619	0	23.6	35	23.2	20	23	23	1
2022-03-04 8:27	23.2	18	630	0	23.6	35	23.2	20	23	23	1
2022-03-04 8:28	23.2	18	638	0	23.6	36	23.2	20	23	23	1
2022-03-04 8:29	23.2	18	647	0	23.5	36	23.2	20	23	23	1
2022-03-04 8:30	23.2	18	651	0	23.5	36	23.2	20	23	23	1
2022-03-04 8:31	23.2	18	653	0	23.5	35	23.2	20	23	23	1
2022-03-04 8:32	23.2	18	658	0	23.5	36	23.2	20	23	23	1
2022-03-04 8:33	23.2	18	662	0	23.5	36	23.2	20	23	23	1
2022-03-04 8:34	23.2	18	669	0	23.5	36	23.2	20	23	23	1
2022-03-04 8:35	23.2	18	674	0	23.4	35	23.1	20	23	23	1
2022-03-04 8:36	23.2	18	677	0	23.4	36	23.1	20	23	23	1
2022-03-04 8:37	23.2	18	684	0	23.4	36	23.1	20	23	23	1
2022-03-04 8:38	23.2	19	690	0	23.4	36	23.1	20	23	23	1
2022-03-04 8:39	23.2	18	696	0	23.4	36	23.1	20	23	23	1
2022-03-04 8:40	23.2	18	701	0	23.4	36	23.1	20	23	23	1
2022-03-04 8:41	23.2	19	706	0	23.4	36	23.1	20	22.9	23	1
2022-03-04 8:42	23.2	19	709	0	23.3	36	23.1	20	22.9	23	1
2022-03-04 8:43	23.2	18	711	0	23.3	36	23	20	22.9	23	1
2022-03-04 8:44	23.2	19	715	0	23.3	36	23	20	22.9	23	1
2022-03-04 8:45	23.2	19	719	0	23.3	36	23	20	22.9	23	1
2022-03-04 8:46	23.2	19	725	0	23.3	36	23	20	22.9	23	1
2022-03-04 8:47	23.2	18	732	0	23.3	37	23	20	22.9	23	1
2022-03-04 8:48	23.2	18	738	0	23.3	36	23	20	22.9	23	1
2022-03-04 8:49	23.2	19	743	0	23.2	36	23	20	22.9	23	1
2022-03-04 8:50	23.2	19	748	0	23.2	37	22.9	20	22.9	23	1
2022-03-04 8:51	23.2	19	751	0	23.2	37	22.9	20	22.9	23	1
2022-03-04 8:52	23.2	19	753	0	23.2	37	22.9	20	22.9	23	1
2022-03-04 8:53	23.1	19	755	0	23.2	37	22.9	20	22.9	23	1
2022-03-04 8:54	23.1	19	758	0	23.2	37	22.9	20	22.9	23	1
2022-03-04 8:55	23.1	19	760	0	23.2	37	22.9	20	22.8	23	1
2022-03-04 8:56	23.1	19	762	0	23.2	37	22.9	20	22.8	23	1
2022-03-04 8:57	23.1	19	765	0	23.1	37	22.9	20	22.8	23	1
2022-03-04 8:58	23.1	19	767	0	23.1	37	22.8	20	22.8	23	1
2022-03-04 8:59	23.1	19	769	0	23.1	37	22.8	20	22.8	23	1

Date and Time	Office				Master bedroom		Foyer (Entrance)		Living room		
	Temperature (°C)	RH (%)	CO2 Concentration (ppm)	Motion Sensor status	Temperature (°C)	RH (%)	Temperature (°C)	RH (%)	Temperature (°C)	RH (%)	Motion Sensor status
2022-03-04 9:00	23.1	19	771	0	23.1	37	22.8	20	22.8	23	1
2022-03-04 9:01	23.1	19	771	0	23.1	37	22.8	20	22.8	23	1
2022-03-04 9:02	23.1	19	772	0	23.1	37	22.8	20	22.8	23	1
2022-03-04 9:03	23.1	19	773	0	23.1	37	22.8	20	22.8	23	1
2022-03-04 9:04	23.1	19	773	0	23	37	22.8	20	22.8	23	1
2022-03-04 9:05	23.1	19	773	0	23	35	22.8	20	22.8	23	1
2022-03-04 9:06	23.1	19	772	0	23	34	22.7	20	22.8	23	1
2022-03-04 9:07	23.2	19	770	0	23	33	22.7	20	22.8	23	1
2022-03-04 9:08	23.2	18	755	0	23	32	22.7	20	22.7	23	1
2022-03-04 9:09	23.2	18	744	0	23	32	22.7	21	22.7	22	1
2022-03-04 9:10	23.2	18	738	0	23	31	22.7	21	22.7	22	N/A
2022-03-04 9:11	23.3	18	731	0	23	31	22.7	21	22.8	22	1
2022-03-04 9:12	23.3	18	727	0	23.1	31	22.7	21	22.8	22	1
2022-03-04 9:13	23.3	18	724	0	23.1	30	22.7	21	22.8	22	1
2022-03-04 9:14	23.4	17	721	0	23.2	30	22.8	21	22.8	22	1
2022-03-04 9:15	23.4	17	715	0	23.3	30	22.8	21	22.8	22	1
2022-03-04 9:16	23.5	17	710	0	23.3	29	22.8	21	22.8	22	1
2022-03-04 9:17	23.5	17	706	0	23.3	29	22.8	21	22.9	22	1
2022-03-04 9:18	23.5	17	704	0	23.4	29	22.8	21	22.9	22	1
2022-03-04 9:19	23.6	17	703	0	23.4	29	22.8	21	22.9	22	1
2022-03-04 9:20	23.6	17	699	1	23.5	29	22.8	21	22.9	22	0
2022-03-04 9:21	23.6	17	695	1	23.5	28	22.9	21	23	22	0
2022-03-04 9:22	23.7	17	698	1	23.6	29	22.9	21	23	22	0
2022-03-04 9:23	23.7	18	709	1	23.6	29	22.9	21	23	22	0
2022-03-04 9:24	23.7	17	718	1	23.6	30	22.9	21	23	22	0
2022-03-04 9:25	23.7	17	732	1	23.6	30	22.9	21	23	22	0
2022-03-04 9:26	23.7	17	736	1	23.6	30	22.9	21	23	22	0
2022-03-04 9:27	23.7	17	744	1	23.6	31	22.9	21	23	23	0
2022-03-04 9:28	23.6	17	765	1	23.6	31	22.9	21	23	23	0
2022-03-04 9:29	23.6	18	788	1	23.6	31	22.9	21	23	23	0
2022-03-04 9:30	23.6	18	806	1	23.6	31	22.9	21	23	23	0
2022-03-04 9:31	23.6	18	824	1	23.6	32	22.9	21	23	23	0
2022-03-04 9:32	23.5	18	838	1	23.6	32	22.9	21	23	23	0
2022-03-04 9:33	23.5	18	851	1	23.6	33	22.9	21	23	23	0
2022-03-04 9:34	23.5	18	861	1	23.6	34	22.9	21	23	23	0
2022-03-04 9:35	23.5	18	865	1	23.6	34	22.9	21	23	23	0
2022-03-04 9:36	23.5	19	869	1	23.6	34	22.9	21	23	23	0
2022-03-04 9:37	23.5	19	878	1	23.6	34	22.9	21	23	23	0
2022-03-04 9:38	23.5	19	896	1	23.6	35	22.9	21	23	23	0
2022-03-04 9:39	23.5	19	912	1	23.6	35	22.9	21	23	23	0
2022-03-04 9:40	23.5	19	915	0	23.6	35	22.9	21	23	23	1
2022-03-04 9:41	23.5	19	924	0	23.6	36	22.9	21	22.9	23	1
2022-03-04 9:42	23.5	19	934	0	23.6	36	22.9	21	22.9	23	1
2022-03-04 9:43	23.5	19	931	0	23.5	36	22.9	21	22.9	23	1
2022-03-04 9:44	23.5	19	924	0	23.5	36	22.9	21	22.9	23	1
2022-03-04 9:45	23.5	19	920	0	23.5	37	22.9	21	22.9	23	1
2022-03-04 9:46	23.4	19	918	0	23.5	36	22.9	21	22.9	23	1
2022-03-04 9:47	23.4	19	917	0	23.5	37	22.9	21	22.9	23	1
2022-03-04 9:48	23.4	19	915	0	23.5	37	22.9	21	22.9	23	1
2022-03-04 9:49	23.4	19	913	0	23.5	37	22.9	21	22.9	23	1
2022-03-04 9:50	23.4	19	912	0	23.5	37	22.8	20	22.9	23	1
2022-03-04 9:51	23.4	19	912	0	23.5	37	22.8	20	22.9	23	1
2022-03-04 9:52	23.4	19	910	0	23.5	37	22.8	20	22.9	23	1
2022-03-04 9:53	23.4	19	909	0	23.4	37	22.8	19	22.9	23	1
2022-03-04 9:54	23.4	19	909	0	23.4	37	22.8	19	22.9	22	1
2022-03-04 9:55	23.4	19	908	0	23.4	37	22.7	19	22.9	22	1
2022-03-04 9:56	23.4	19	906	0	23.4	36	22.7	19	22.9	22	1
2022-03-04 9:57	23.4	19	906	0	23.4	36	22.7	17	22.8	22	1
2022-03-04 9:58	23.3	19	904	0	23.4	36	22.5	16	22.8	21	1
2022-03-04 9:59	23.3	19	901	0	23.4	35	22.4	17	22.8	20	1
2022-03-04 10:00	23.3	19	898	0	23.4	33	22.3	18	22.8	21	1
2022-03-04 10:01	23.3	19	897	0	23.4	32	22.3	19	22.8	22	1
2022-03-04 10:02	23.3	18	893	0	23.4	31	22.3	19	22.8	22	1
2022-03-04 10:03	23.4	18	882	0	23.4	31	22.2	19	22.8	22	1
2022-03-04 10:04	23.4	18	864	0	23.4	30	22.2	19	22.8	21	1
2022-03-04 10:05	23.5	18	847	0	23.5	30	22.2	20	22.8	21	1
2022-03-04 10:06	23.5	18	832	0	23.5	30	22.2	20	22.8	22	1
2022-03-04 10:07	23.5	18	819	0	23.5	30	22.2	20	22.8	22	1
2022-03-04 10:08	23.6	17	808	0	23.6	29	22.2	20	22.8	22	1
2022-03-04 10:09	23.6	17	797	0	23.7	29	22.2	20	22.8	22	1
2022-03-04 10:10	23.7	17	790	0	23.7	29	22.2	20	22.8	22	1
2022-03-04 10:11	23.7	18	780	0	23.7	29	22.2	20	22.9	22	1
2022-03-04 10:12	23.7	18	771	0	23.8	29	22.3	20	22.9	22	1
2022-03-04 10:13	23.8	17	763	0	23.9	28	22.3	20	22.9	22	1
2022-03-04 10:14	23.8	17	755	0	23.9	28	22.3	20	22.9	22	1
2022-03-04 10:15	23.8	17	749	0	24	28	22.3	20	23	22	1
2022-03-04 10:16	23.9	17	741	0	24	28	22.3	19	23	22	1
2022-03-04 10:17	23.9	17	732	0	24.1	28	22.3	20	23	22	1
2022-03-04 10:18	23.9	17	729	0	24.1	28	22.3	20	23	22	1
2022-03-04 10:19	23.9	17	727	0	24.1	29	22.3	19	23	20	0
2022-03-04 10:20	23.9	17	724	0	24.1	31	22.2	19	23	19	0
2022-03-04 10:21	23.8	17	721	0	24.1	32	22.2	19	23	19	0
2022-03-04 10:22	23.8	17	721	0	24.1	33	22.1	19	23	20	0
2022-03-04 10:23	23.8	17	718	0	24	33	22.1	19	23	20	0
2022-03-04 10:24	23.7	17	716	0	24	34	22.1	19	23	20	0
2022-03-04 10:25	23.7	17	713	0	24	34	22.1	19	23	21	0
2022-03-04 10:26	23.7	17	710	0	24	34	22.1	19	23	21	0
2022-03-04 10:27	23.6	17	706	0	24	35	22.1	19	22.9	21	0
2022-03-04 10:28	23.6	17	706	0	24	35	22.1	19	22.9	21	0
2022-03-04 10:29	23.6	17	706	0	24	35	22.1	19	22.9	21	0

Date and Time	Office				Master bedroom		Foyer (Entrance)		Living room		
	Temperature (°C)	RH (%)	CO2 Concentration (ppm)	Motion Sensor status	Temperature (°C)	RH (%)	Temperature (°C)	RH (%)	Temperature (°C)	RH (%)	Motion Sensor status
2022-03-04 10:30	23.6	17	706	0	24	35	22.1	19	22.9	21	0
2022-03-04 10:31	23.6	17	704	0	23.9	36	22.1	19	22.9	21	0
2022-03-04 10:32	23.5	17	702	0	23.9	36	22.1	19	22.9	21	0
2022-03-04 10:33	23.5	17	699	0	23.9	36	22.1	19	22.9	21	0
2022-03-04 10:34	23.5	17	699	0	23.9	36	22.1	19	22.9	21	0
2022-03-04 10:35	23.5	17	697	0	23.9	36	22.1	19	22.9	21	0
2022-03-04 10:36	23.5	18	698	0	23.9	36	22	19	22.9	21	0
2022-03-04 10:37	23.5	17	700	0	23.9	36	22	19	22.9	21	0
2022-03-04 10:38	23.5	17	699	0	23.8	36	22	19	22.9	21	0
2022-03-04 10:39	23.5	17	699	0	23.8	37	22	19	22.9	21	0
2022-03-04 10:40	23.5	17	699	0	23.8	37	22	19	22.8	21	0
2022-03-04 10:41	23.5	18	700	0	23.8	34	22	19	22.8	21	0
2022-03-04 10:42	23.5	17	699	0	23.8	32	22	20	22.8	22	0
2022-03-04 10:43	23.5	17	698	0	23.8	31	22	20	22.8	21	0
2022-03-04 10:44	23.5	17	694	0	23.8	30	22	20	22.8	21	0
2022-03-04 10:45	23.5	17	690	0	23.8	30	22	20	22.8	21	0
2022-03-04 10:46	23.6	17	681	0	23.9	30	22	20	22.8	21	0
2022-03-04 10:47	23.6	17	673	0	23.9	30	22	20	22.8	21	0
2022-03-04 10:48	23.7	17	666	0	23.9	29	22.1	20	22.9	21	0
2022-03-04 10:49	23.7	17	660	0	24	29	22.1	20	22.9	21	0
2022-03-04 10:50	23.8	17	655	0	24	29	22.1	20	22.9	21	0
2022-03-04 10:51	23.8	17	652	0	24.1	28	22.1	20	22.9	22	0
2022-03-04 10:52	23.8	17	648	0	24.1	28	22.1	21	22.9	22	0
2022-03-04 10:53	23.9	17	644	0	24.2	28	22.1	21	23	22	0
2022-03-04 10:54	23.9	17	639	0	24.2	28	22.2	21	23	22	0
2022-03-04 10:55	23.9	17	637	0	24.3	28	22.2	21	23	22	0
2022-03-04 10:56	24	17	633	0	24.3	28	22.3	21	23.1	22	0
2022-03-04 10:57	24	17	630	0	24.4	28	22.3	21	23.1	22	0
2022-03-04 10:58	24	17	629	0	24.4	29	22.3	21	23.1	22	0
2022-03-04 10:59	23.9	17	628	0	24.4	30	22.3	21	23.1	22	1
2022-03-04 11:00	23.9	17	627	0	24.4	30	22.3	21	23.1	22	1
2022-03-04 11:01	23.9	17	627	0	24.4	30	22.3	28	23.1	22	1
2022-03-04 11:02	23.8	17	626	0	24.4	31	22.1	30	23.1	22	1
2022-03-04 11:03	23.8	17	624	0	24.4	32	21.9	32	23.1	21	1
2022-03-04 11:04	23.8	17	624	0	24.4	32	21.8	33	23.1	21	1
2022-03-04 11:05	23.8	17	622	0	24.3	32	21.6	36	23.1	22	1
2022-03-04 11:06	23.7	17	621	0	24.3	32	21.4	38	23	22	1
2022-03-04 11:07	23.7	17	620	0	24.3	31	21.3	39	23	22	1
2022-03-04 11:08	23.7	17	619	0	24.3	32	21.2	40	23	22	1
2022-03-04 11:09	23.7	17	618	0	24.3	32	21.2	41	23	22	1
2022-03-04 11:10	23.6	17	617	0	24.2	32	21.1	42	23	22	1
2022-03-04 11:11	23.6	17	616	0	24.2	31	21	42	23	23	1
2022-03-04 11:12	23.6	17	616	0	24.2	31	20.9	43	23	22	1
2022-03-04 11:13	23.6	17	616	0	24.2	31	20.9	43	23	23	1
2022-03-04 11:14	23.6	17	616	0	24.2	32	20.9	45	23	23	1
2022-03-04 11:15	23.6	17	617	0	24.2	33	20.8	45	23	23	1
2022-03-04 11:16	23.6	17	618	0	24.2	33	20.8	46	23	23	1
2022-03-04 11:17	23.6	17	617	0	24.1	34	20.7	46	23	23	1
2022-03-04 11:18	23.5	17	617	0	24.1	33	20.7	46	23	23	1
2022-03-04 11:19	23.5	17	616	0	24.1	33	20.6	47	23	24	1
2022-03-04 11:20	23.5	17	616	0	24.1	33	20.6	47	23	24	1
2022-03-04 11:21	23.5	17	616	0	24.1	34	20.6	47	23	24	1
2022-03-04 11:22	23.5	17	617	1	24.1	34	20.6	48	23	24	1
2022-03-04 11:23	23.5	17	617	1	24.1	33	20.6	48	23	24	1
2022-03-04 11:24	23.5	18	617	0	24.1	33	20.5	49	23	24	1
2022-03-04 11:25	23.5	17	618	0	24	33	20.5	49	22.9	24	1
2022-03-04 11:26	23.5	18	625	0	24	34	20.5	49	22.9	24	1
2022-03-04 11:27	23.5	18	634	0	24	34	20.5	50	22.9	24	1
2022-03-04 11:28	23.5	18	640	0	24	35	20.5	50	22.9	24	1
2022-03-04 11:29	23.5	18	643	0	24	35	20.4	51	22.9	24	1
2022-03-04 11:30	23.5	18	644	0	24	35	20.4	51	22.9	24	1
2022-03-04 11:31	23.5	18	644	0	24	35	20.4	51	22.9	24	1
2022-03-04 11:32	23.5	19	643	0	24	35	20.4	51	22.9	24	1
2022-03-04 11:33	23.5	18	643	0	24	35	20.4	51	22.9	24	1
2022-03-04 11:34	23.5	18	642	0	24	35	20.4	51	22.9	24	1
2022-03-04 11:35	23.5	18	643	0	24	35	20.4	51	22.9	24	1
2022-03-04 11:36	23.5	19	644	0	23.9	35	20.4	51	22.9	24	1
2022-03-04 11:37	23.5	18	643	0	23.9	34	20.4	51	22.9	24	1
2022-03-04 11:38	23.5	19	643	0	23.9	34	20.4	51	22.9	24	1
2022-03-04 11:39	23.5	18	643	0	23.9	34	20.4	50	22.9	24	1
2022-03-04 11:40	23.5	18	644	0	23.9	34	20.4	51	22.9	24	1
2022-03-04 11:41	23.4	18	645	0	23.9	35	20.3	51	23	27	1
2022-03-04 11:42	23.4	18	645	0	23.9	34	20.3	51	23.2	25	1
2022-03-04 11:43	23.4	18	645	0	23.9	34	20.3	50	23.1	25	1
2022-03-04 11:44	23.4	18	645	0	23.9	33	20.3	50	23.1	25	1
2022-03-04 11:45	23.4	18	645	0	23.9	31	20.3	43	23.1	25	1
2022-03-04 11:46	23.4	18	644	0	23.9	30	20.4	47	23	25	0
2022-03-04 11:47	23.5	19	643	0	23.9	30	20.4	43	23	24	0
2022-03-04 11:48	23.5	18	642	0	23.9	29	20.4	44	23	24	0
2022-03-04 11:49	23.5	18	639	0	23.9	29	20.5	43	23	24	0
2022-03-04 11:50	23.6	18	635	0	23.9	29	20.6	42	23	24	0
2022-03-04 11:51	23.6	18	634	0	24	28	20.6	40	23.1	24	0
2022-03-04 11:52	23.6	18	633	0	24	28	20.7	39	23.1	24	0
2022-03-04 11:53	23.7	18	629	0	24	28	20.7	38	23.1	24	0
2022-03-04 11:54	23.7	18	627	0	24.1	27	20.8	38	23.1	24	0
2022-03-04 11:55	23.8	18	628	0	24.1	27	20.9	37	23.1	24	0
2022-03-04 11:56	23.8	18	625	0	24.2	27	20.9	36	23.1	24	0
2022-03-04 11:57	23.8	18	623	0	24.2	27	21	37	23.1	24	0
2022-03-04 11:58	23.8	18	624	0	24.2	28	21	37	23.2	23	0
2022-03-04 11:59	23.8	18	623	0	24.2	28	21.1	38	23.1	23	0

Date and Time	Office				Master bedroom		Foyer (Entrance)		Living room		
	Temperature (°C)	RH (%)	CO2 Concentration (ppm)	Motion Sensor status	Temperature (°C)	RH (%)	Temperature (°C)	RH (%)	Temperature (°C)	RH (%)	Motion Sensor status
2022-03-04 12:00	23.8	18	623	0	24.3	28	21.1	39	23.2	23	0
2022-03-04 12:01	23.8	17	622	0	24.3	29	21.2	39	23.1	24	0
2022-03-04 12:02	23.8	17	623	0	24.2	29	21.2	39	23.1	24	0
2022-03-04 12:03	23.7	18	622	0	24.2	29	21.2	40	23.1	24	0
2022-03-04 12:04	23.7	17	622	0	24.2	29	21.3	40	23.1	24	0
2022-03-04 12:05	23.7	18	621	0	24.2	29	21.3	40	23.1	24	0
2022-03-04 12:06	23.6	18	620	0	24.2	29	21.3	40	23.1	24	0
2022-03-04 12:07	23.6	17	619	0	24.2	29	21.3	40	23.1	24	0
2022-03-04 12:08	23.6	17	618	0	24.1	29	21.3	40	23.1	24	0
2022-03-04 12:09	23.6	18	618	0	24.1	29	21.3	41	23.1	24	0
2022-03-04 12:10	23.6	18	618	0	24.1	29	21.3	41	23.1	24	0
2022-03-04 12:11	23.5	18	617	0	24.1	29	21.4	41	23.1	24	0
2022-03-04 12:12	23.5	18	617	0	24.1	29	21.4	41	23.1	24	0
2022-03-04 12:13	23.5	17	617	0	24.1	29	21.4	41	23.1	24	0
2022-03-04 12:14	23.5	17	616	0	24.1	29	21.4	41	23.1	24	0
2022-03-04 12:15	23.5	17	616	0	24.1	29	21.4	41	23.1	24	0
2022-03-04 12:16	23.5	18	616	0	24	29	21.5	41	23.1	24	0
2022-03-04 12:17	23.5	18	617	0	24	30	21.5	41	23.1	24	0
2022-03-04 12:18	23.5	18	616	0	24	30	21.5	41	23	24	0
2022-03-04 12:19	23.5	18	616	0	24	30	21.5	41	23.1	24	0
2022-03-04 12:20	23.5	18	616	0	24	30	21.5	41	23	24	0
2022-03-04 12:21	23.5	18	616	0	24	30	21.5	41	23	24	0
2022-03-04 12:22	23.5	18	616	0	24	30	21.5	41	23	24	0
2022-03-04 12:23	23.5	18	616	0	24	30	21.5	41	23	24	0
2022-03-04 12:24	23.5	18	617	0	23.9	30	21.5	41	23	24	0
2022-03-04 12:25	23.5	18	617	0	23.9	30	21.5	41	23	24	0
2022-03-04 12:26	23.5	18	618	0	23.9	30	21.5	41	23	24	0
2022-03-04 12:27	23.4	18	618	0	23.9	30	21.5	41	23	24	0
2022-03-04 12:28	23.4	18	617	0	23.9	30	21.5	41	23	24	0
2022-03-04 12:29	23.4	18	618	0	23.9	30	21.5	41	23	24	0
2022-03-04 12:30	23.4	18	617	0	23.9	30	21.5	41	23	24	0
2022-03-04 12:31	23.4	18	618	0	23.9	30	21.5	41	23	24	0
2022-03-04 12:32	23.4	18	618	0	23.9	30	21.5	41	23	23	0
2022-03-04 12:33	23.4	18	618	0	23.9	30	21.5	41	23	23	0
2022-03-04 12:34	23.4	18	618	0	23.8	30	21.5	41	23	23	0
2022-03-04 12:35	23.4	18	618	0	23.8	30	21.5	41	23	23	0
2022-03-04 12:36	23.4	18	618	0	23.8	30	21.5	41	23	23	0
2022-03-04 12:37	23.4	18	618	0	23.8	30	21.6	41	23	23	0
2022-03-04 12:38	23.4	18	618	0	23.8	30	21.6	41	22.9	23	0
2022-03-04 12:39	23.4	18	618	0	23.8	30	21.6	41	22.9	23	0
2022-03-04 12:40	23.4	18	618	0	23.8	30	21.5	41	22.9	23	0
2022-03-04 12:41	23.4	18	618	0	23.8	30	21.5	41	22.9	23	0
2022-03-04 12:42	23.4	18	617	0	23.7	30	21.5	41	22.9	23	0
2022-03-04 12:43	23.4	18	618	0	23.7	30	21.5	41	22.9	23	0
2022-03-04 12:44	23.4	18	618	0	23.7	30	21.5	41	22.9	23	0
2022-03-04 12:45	23.4	18	618	0	23.7	30	21.5	41	22.9	23	0
2022-03-04 12:46	23.3	18	619	0	23.8	30	21.5	41	22.9	23	0
2022-03-04 12:47	23.3	18	619	0	23.8	30	21.5	41	22.9	23	0
2022-03-04 12:48	23.3	18	618	0	23.7	30	21.5	41	22.9	23	0
2022-03-04 12:49	23.3	18	619	0	23.7	30	21.5	41	22.9	23	0
2022-03-04 12:50	23.3	18	619	0	23.7	30	21.5	41	22.8	23	0
2022-03-04 12:51	23.3	18	618	0	23.7	30	21.5	41	22.8	23	0
2022-03-04 12:52	23.3	18	618	0	23.7	30	21.5	41	22.8	23	0
2022-03-04 12:53	23.3	18	618	0	23.7	30	21.5	41	22.8	23	0
2022-03-04 12:54	23.3	18	618	0	23.7	30	21.5	41	22.8	23	0
2022-03-04 12:55	23.3	18	618	0	23.7	30	21.5	41	22.8	23	0
2022-03-04 12:56	23.3	18	618	0	23.6	30	21.5	41	22.8	23	0
2022-03-04 12:57	23.3	18	617	0	23.6	30	21.5	41	22.8	23	0
2022-03-04 12:58	23.3	18	617	0	23.6	30	21.5	41	22.8	23	0
2022-03-04 12:59	23.3	18	618	0	23.6	30	21.5	41	22.8	23	0
2022-03-04 13:00	23.3	18	617	0	23.6	30	21.5	41	22.8	23	0
2022-03-04 13:01	23.3	18	617	0	23.6	30	21.5	41	22.7	23	0
2022-03-04 13:02	23.3	18	618	0	23.6	30	21.5	41	22.7	23	0
2022-03-04 13:03	23.3	18	618	0	23.6	30	21.5	41	22.7	23	0
2022-03-04 13:04	23.3	18	618	0	23.6	30	21.5	41	22.7	23	0
2022-03-04 13:05	23.3	18	618	0	23.6	30	21.5	41	22.7	23	0
2022-03-04 13:06	23.3	18	618	0	23.6	30	21.5	41	22.7	23	0
2022-03-04 13:07	23.3	18	618	0	23.5	30	21.5	41	22.7	23	0
2022-03-04 13:08	23.2	18	618	0	23.5	30	21.4	41	22.7	23	0
2022-03-04 13:09	23.2	18	618	0	23.5	30	21.4	41	22.7	22	0
2022-03-04 13:10	23.2	19	618	0	23.5	30	21.4	41	22.7	22	0
2022-03-04 13:11	23.2	19	617	0	23.5	30	21.4	41	22.7	22	0
2022-03-04 13:12	23.2	18	616	0	23.5	30	21.4	41	22.6	22	0
2022-03-04 13:13	23.2	18	616	0	23.5	30	21.4	41	22.6	22	0
2022-03-04 13:14	23.2	19	617	0	23.6	30	21.4	41	22.6	22	0
2022-03-04 13:15	23.2	18	617	0	23.6	30	21.4	41	22.6	22	0
2022-03-04 13:16	23.2	18	617	0	23.6	30	21.4	41	22.6	22	0
2022-03-04 13:17	23.2	18	616	0	23.6	31	21.4	41	22.6	22	0
2022-03-04 13:18	23.2	18	616	0	23.6	31	21.3	41	22.6	22	0
2022-03-04 13:19	23.2	18	616	0	23.7	31	21.3	41	22.6	22	0
2022-03-04 13:20	23.2	19	617	0	23.7	31	21.3	41	22.6	22	0
2022-03-04 13:21	23.2	19	617	0	23.7	31	21.3	41	22.6	22	0
2022-03-04 13:22	23.2	19	617	0	23.7	31	21.3	41	22.6	22	0
2022-03-04 13:23	23.2	19	617	0	23.7	31	21.3	41	22.5	22	0
2022-03-04 13:24	23.2	18	617	0	23.7	31	21.3	41	22.5	22	0
2022-03-04 13:25	23.2	18	618	0	23.7	30	21.3	41	22.5	22	0
2022-03-04 13:26	23.2	18	617	0	23.7	31	21.3	41	22.5	22	0
2022-03-04 13:27	23.2	19	617	0	23.7	31	21.3	41	22.5	22	0
2022-03-04 13:28	23.2	19	617	0	23.7	31	21.3	41	22.5	22	0
2022-03-04 13:29	23.2	19	617	0	23.7	31	21.3	41	22.5	22	0

Date and Time	Office				Master bedroom		Foyer (Entrance)		Living room		
	Temperature (°C)	RH (%)	CO2 Concentration (ppm)	Motion Sensor status	Temperature (°C)	RH (%)	Temperature (°C)	RH (%)	Temperature (°C)	RH (%)	Motion Sensor status
2022-03-04 13:30	23.2	18	616	0	23.7	30	21.3	41	22.5	22	0
2022-03-04 13:31	23.2	18	616	0	23.7	30	21.3	41	22.5	22	0
2022-03-04 13:32	23.1	18	616	0	23.7	30	21.3	41	22.4	22	0
2022-03-04 13:33	23.1	19	615	0	23.7	30	21.2	40	22.4	22	0
2022-03-04 13:34	23.1	18	615	0	23.7	30	21.2	40	22.4	22	0
2022-03-04 13:35	23.1	18	616	0	23.7	30	21.2	40	22.4	22	0
2022-03-04 13:36	23.1	18	616	0	23.7	30	21.2	40	22.4	22	0
2022-03-04 13:37	23.1	18	615	0	23.7	30	21.2	40	22.4	22	0
2022-03-04 13:38	23.1	18	615	0	23.7	30	21.2	40	22.4	22	0
2022-03-04 13:39	23.1	18	615	0	23.7	30	21.2	40	22.4	22	0
2022-03-04 13:40	23.1	18	615	0	23.7	30	21.2	40	22.4	22	0
2022-03-04 13:41	23.1	18	615	0	23.7	30	21.2	40	22.4	22	0
2022-03-04 13:42	23.1	18	614	0	23.7	30	21.2	40	22.4	22	0
2022-03-04 13:43	23.1	18	614	0	23.7	30	21.1	40	22.3	22	0
2022-03-04 13:44	23.1	19	614	0	23.7	30	21.1	40	22.3	22	0
2022-03-04 13:45	23.1	19	614	0	23.6	30	21.1	40	22.3	22	0
2022-03-04 13:46	23.1	18	613	0	23.6	30	21.1	40	22.3	22	0
2022-03-04 13:47	23.1	18	613	0	23.6	30	21.1	40	22.3	22	0
2022-03-04 13:48	23.1	19	613	0	23.6	30	21.1	40	22.3	22	0
2022-03-04 13:49	23.1	19	613	0	23.6	30	21.1	40	22.3	22	0
2022-03-04 13:50	23.1	19	613	0	23.6	30	21.1	40	22.3	22	0
2022-03-04 13:51	23.1	18	613	0	23.6	30	21.1	40	22.3	22	0
2022-03-04 13:52	23	19	613	0	23.6	30	21.1	40	22.2	22	0
2022-03-04 13:53	23	18	613	0	23.6	30	21	40	22.2	22	0
2022-03-04 13:54	23	18	614	0	23.6	30	21	40	22.2	22	0
2022-03-04 13:55	23	19	612	0	23.6	30	21	40	22.2	22	0
2022-03-04 13:56	23	19	612	0	23.6	30	21	40	22.2	22	0
2022-03-04 13:57	23	18	612	0	23.6	30	21	40	22.2	22	0
2022-03-04 13:58	23	19	612	0	23.6	30	21	40	22.2	22	0
2022-03-04 13:59	23	19	612	0	23.6	30	21	40	22.2	22	0
2022-03-04 14:00	23	18	612	0	23.5	30	21	40	22.2	22	0
2022-03-04 14:01	23	18	612	0	23.5	30	21	40	22.1	22	0
2022-03-04 14:02	23	19	611	0	23.5	30	21	40	22.1	22	0
2022-03-04 14:03	23	19	610	0	23.5	30	20.9	40	22.1	22	0
2022-03-04 14:04	23	18	610	0	23.5	30	20.9	40	22.1	22	0
2022-03-04 14:05	23	18	610	0	23.5	30	20.9	40	22.1	22	0
2022-03-04 14:06	23	18	610	0	23.5	30	20.9	40	22.1	22	0
2022-03-04 14:07	23	18	611	0	23.5	30	20.9	31	22.1	22	0
2022-03-04 14:08	23	18	610	0	23.5	30	20.8	28	22.1	20	1
2022-03-04 14:09	23	18	608	0	23.5	30	20.6	24	22	19	1
2022-03-04 14:10	23	18	604	0	23.5	29	20.4	28	22	19	1
2022-03-04 14:11	23	18	602	0	23.5	28	20.3	27	21.9	20	1
2022-03-04 14:12	23	18	601	0	23.5	27	20.3	29	21.9	21	1
2022-03-04 14:13	23	18	598	0	23.4	27	20.3	29	21.9	21	1
2022-03-04 14:14	23	18	597	0	23.5	26	20.3	29	21.9	21	1
2022-03-04 14:15	23	18	596	0	23.5	26	20.3	29	21.9	21	1
2022-03-04 14:16	23.1	18	590	0	23.5	26	20.3	30	21.9	21	1
2022-03-04 14:17	23.1	17	585	0	23.5	26	20.3	28	21.9	21	1
2022-03-04 14:18	23.2	18	582	0	23.6	25	20.3	28	21.9	22	1
2022-03-04 14:19	23.2	17	581	0	23.6	24	20.3	28	22	22	1
2022-03-04 14:20	23.3	17	578	0	23.7	24	20.3	27	22	22	1
2022-03-04 14:21	23.3	17	574	0	23.7	23	20.3	27	22	22	1
2022-03-04 14:22	23.3	17	571	0	23.7	23	20.3	26	22	22	1
2022-03-04 14:23	23.4	17	569	0	23.8	23	20.3	26	22.1	22	1
2022-03-04 14:24	23.4	17	569	0	23.8	23	20.3	26	22.1	22	1
2022-03-04 14:25	23.4	17	567	0	23.9	23	20.4	26	22.1	22	1
2022-03-04 14:26	23.5	17	566	0	23.9	23	20.4	26	22.1	22	1
2022-03-04 14:27	23.5	17	565	0	24	23	20.4	26	22.2	22	1
2022-03-04 14:28	23.5	17	564	0	24	23	20.5	25	22.2	22	1
2022-03-04 14:29	23.5	17	563	0	24	22	20.5	25	22.2	22	1
2022-03-04 14:30	23.6	17	560	0	24.1	22	20.5	25	22.2	22	1
2022-03-04 14:31	23.6	17	560	0	24.1	22	20.6	25	22.3	22	1
2022-03-04 14:32	23.6	17	560	0	24.2	22	20.6	25	22.3	22	1
2022-03-04 14:33	23.7	17	560	0	24.2	22	20.6	25	22.4	22	1
2022-03-04 14:34	23.7	17	560	0	24.3	22	20.7	25	22.4	22	1
2022-03-04 14:35	23.7	17	560	0	24.3	22	20.7	25	22.4	22	1
2022-03-04 14:36	23.7	17	560	0	24.4	22	20.8	25	22.4	22	1
2022-03-04 14:37	23.8	17	559	0	24.4	22	20.8	25	22.5	22	1
2022-03-04 14:38	23.8	17	559	0	24.5	22	20.8	25	22.5	22	1
2022-03-04 14:39	23.8	17	558	0	24.5	22	20.9	25	22.6	22	1
2022-03-04 14:40	23.8	17	558	0	24.5	22	20.9	25	22.6	23	1
2022-03-04 14:41	23.9	17	558	0	24.6	22	20.9	25	22.6	23	1
2022-03-04 14:42	23.9	17	565	0	24.6	22	21	25	22.6	23	1
2022-03-04 14:43	23.9	17	572	1	24.6	22	21	25	22.7	23	1
2022-03-04 14:44	23.9	17	576	1	24.7	22	21.1	25	22.7	23	1
2022-03-04 14:45	24	17	581	1	24.7	22	21.1	25	22.8	23	1
2022-03-04 14:46	24	17	584	1	24.7	22	21.2	26	22.8	23	1
2022-03-04 14:47	24	17	589	1	24.8	22	21.2	26	22.8	23	1
2022-03-04 14:48	24.1	17	596	1	24.8	22	21.3	27	22.8	23	1
2022-03-04 14:49	24.1	17	602	1	24.8	22	21.3	28	22.8	23	1
2022-03-04 14:50	24.1	17	607	1	24.8	22	21.3	29	22.8	23	1
2022-03-04 14:51	24.1	17	619	1	24.7	22	21.3	30	22.8	23	1
2022-03-04 14:52	24	17	623	1	24.7	23	21.4	31	22.8	23	1
2022-03-04 14:53	24	18	627	1	24.7	23	21.4	32	22.8	23	1
2022-03-04 14:54	24	18	634	1	24.7	23	21.4	32	22.8	23	1
2022-03-04 14:55	24	18	657	0	24.6	23	21.5	33	22.8	23	1
2022-03-04 14:56	24	18	662	0	24.6	23	21.5	33	22.8	23	1
2022-03-04 14:57	24	18	664	0	24.6	23	21.5	33	22.8	23	1
2022-03-04 14:58	23.9	18	674	0	24.6	23	21.5	34	22.8	23	1
2022-03-04 14:59	23.9	18	680	0	24.6	23	21.5	34	22.8	23	1

Date and Time	Office				Master bedroom		Foyer (Entrance)		Living room		
	Temperature (°C)	RH (%)	CO2 Concentration (ppm)	Motion Sensor status	Temperature (°C)	RH (%)	Temperature (°C)	RH (%)	Temperature (°C)	RH (%)	Motion Sensor status
2022-03-04 15:00	23.9	18	679	0	24.5	24	21.5	34	22.8	23	1
2022-03-04 15:01	23.8	18	676	0	24.5	24	21.5	35	22.8	23	1
2022-03-04 15:02	23.8	18	670	0	24.6	24	21.6	35	22.8	23	1
2022-03-04 15:03	23.8	18	666	0	24.6	24	21.6	35	22.8	23	1
2022-03-04 15:04	23.8	19	665	0	24.6	24	21.6	36	22.8	23	1
2022-03-04 15:05	23.8	18	664	0	24.5	24	21.6	36	22.8	23	1
2022-03-04 15:06	23.8	18	666	0	24.5	24	21.6	36	22.8	23	1
2022-03-04 15:07	23.7	18	668	0	24.5	24	21.6	36	22.8	23	1
2022-03-04 15:08	23.7	19	670	0	24.5	24	21.6	36	22.8	23	1
2022-03-04 15:09	23.7	19	672	0	24.4	24	21.6	36	22.8	23	1
2022-03-04 15:10	23.7	19	673	0	24.4	24	21.6	37	22.8	23	1
2022-03-04 15:11	23.7	19	677	0	24.4	24	21.6	37	22.8	23	1
2022-03-04 15:12	23.7	19	679	0	24.4	24	21.6	37	22.8	23	1
2022-03-04 15:13	23.7	19	679	0	24.4	24	21.6	37	22.8	23	1
2022-03-04 15:14	23.7	19	680	0	24.3	24	21.6	36	22.8	23	1
2022-03-04 15:15	23.7	19	681	0	24.3	24	21.6	36	22.8	23	1
2022-03-04 15:16	23.6	19	682	0	24.3	24	21.6	37	22.8	23	1
2022-03-04 15:17	23.6	19	682	0	24.3	24	21.6	37	22.8	23	1
2022-03-04 15:18	23.6	19	682	0	24.3	25	21.6	37	22.8	23	1
2022-03-04 15:19	23.6	19	682	0	24.3	25	21.6	37	22.8	23	1
2022-03-04 15:20	23.6	19	682	0	24.2	25	21.6	37	22.8	23	1
2022-03-04 15:21	23.6	19	682	0	24.2	25	21.6	37	22.8	23	1
2022-03-04 15:22	23.6	19	683	0	24.2	25	21.6	37	22.8	23	1
2022-03-04 15:23	23.5	19	683	0	24.2	25	21.6	38	22.8	23	1
2022-03-04 15:24	23.5	19	683	0	24.2	25	21.6	38	22.8	23	1
2022-03-04 15:25	23.5	19	682	0	24.1	25	21.6	38	22.8	23	1
2022-03-04 15:26	23.5	19	682	0	24.1	25	21.6	38	22.8	23	1
2022-03-04 15:27	23.5	19	683	0	24.1	25	21.6	38	22.8	23	1
2022-03-04 15:28	23.5	19	682	0	24.1	25	21.6	38	22.7	23	1
2022-03-04 15:29	23.5	19	683	0	24.1	25	21.6	38	22.7	23	1
2022-03-04 15:30	23.5	19	682	0	24.1	25	21.6	38	22.7	23	1
2022-03-04 15:31	23.5	19	681	0	24.1	25	21.6	38	22.7	23	1
2022-03-04 15:32	23.5	19	681	0	24	25	21.6	38	22.7	23	1
2022-03-04 15:33	23.5	19	681	0	24.1	25	21.6	38	22.7	23	1
2022-03-04 15:34	23.4	19	680	0	24.1	25	21.6	38	22.7	23	1
2022-03-04 15:35	23.4	19	680	0	24.1	25	21.6	39	22.7	23	1
2022-03-04 15:36	23.4	19	681	0	24	25	21.6	39	22.7	23	1
2022-03-04 15:37	23.4	19	681	0	24	25	21.6	39	22.7	23	1
2022-03-04 15:38	23.4	19	681	0	24	25	21.6	39	22.7	23	1
2022-03-04 15:39	23.4	19	682	0	24	25	21.6	39	22.7	23	1
2022-03-04 15:40	23.4	19	682	0	24	25	21.6	39	22.7	23	1
2022-03-04 15:41	23.4	19	682	0	24	25	21.6	39	22.7	23	1
2022-03-04 15:42	23.4	19	682	0	24	25	21.6	39	22.7	23	1
2022-03-04 15:43	23.4	19	682	0	23.9	25	21.6	39	22.7	23	1
2022-03-04 15:44	23.4	19	682	0	23.9	25	21.6	39	22.7	23	1
2022-03-04 15:45	23.4	19	682	0	23.9	25	21.5	39	22.7	23	1
2022-03-04 15:46	23.4	19	683	0	23.9	25	21.5	39	22.7	23	1
2022-03-04 15:47	23.4	19	683	0	23.9	25	21.5	39	22.7	23	1
2022-03-04 15:48	23.4	19	684	0	23.9	25	21.5	38	22.7	23	1
2022-03-04 15:49	23.3	19	684	0	23.9	25	21.5	38	22.7	23	1
2022-03-04 15:50	23.3	19	685	0	23.8	25	21.5	38	22.7	23	1
2022-03-04 15:51	23.3	19	684	0	23.8	25	21.5	37	22.7	23	1
2022-03-04 15:52	23.3	19	683	0	23.8	26	21.5	36	22.7	23	1
2022-03-04 15:53	23.3	19	684	0	23.8	26	21.5	37	22.7	23	1
2022-03-04 15:54	23.3	19	684	0	23.8	26	21.5	37	22.7	23	1
2022-03-04 15:55	23.3	19	684	0	23.8	26	21.5	37	22.7	23	1
2022-03-04 15:56	23.3	19	684	0	23.8	26	21.5	38	22.7	23	1
2022-03-04 15:57	23.3	19	684	0	23.7	26	21.5	38	22.6	23	1
2022-03-04 15:58	23.3	19	684	0	23.7	26	21.5	38	22.6	23	1
2022-03-04 15:59	23.3	19	684	0	23.7	26	21.4	38	22.6	23	1
2022-03-04 16:00	23.3	19	684	0	23.7	26	21.4	38	22.6	23	1
2022-03-04 16:01	23.3	19	684	0	23.7	26	21.4	38	22.6	23	1
2022-03-04 16:02	23.2	19	684	0	23.7	26	21.4	38	22.6	24	1
2022-03-04 16:03	23.2	19	684	0	23.7	26	21.4	38	22.6	24	1
2022-03-04 16:04	23.2	19	684	0	23.7	26	21.4	38	22.6	24	1
2022-03-04 16:05	23.2	19	684	0	23.7	26	21.4	38	22.6	23	1
2022-03-04 16:06	23.2	19	683	0	23.7	26	21.4	38	22.6	23	1
2022-03-04 16:07	23.2	19	683	0	23.6	26	21.4	38	22.6	24	1
2022-03-04 16:08	23.2	19	683	0	23.6	26	21.4	38	22.6	24	1
2022-03-04 16:09	23.2	19	683	0	23.6	25	21.4	37	22.6	23	1
2022-03-04 16:10	23.2	19	681	0	23.6	25	21.3	37	22.6	24	1
2022-03-04 16:11	23.2	19	677	0	23.6	24	21.3	36	22.6	24	1
2022-03-04 16:12	23.2	19	676	0	23.6	24	21.3	35	22.6	23	1
2022-03-04 16:13	23.3	18	674	0	23.6	24	21.3	35	22.6	23	1
2022-03-04 16:14	23.3	19	669	0	23.6	24	21.3	33	22.6	23	1
2022-03-04 16:15	23.4	18	663	0	23.7	24	21.3	34	22.6	23	1
2022-03-04 16:16	23.4	18	660	0	23.7	23	21.4	33	22.6	23	1
2022-03-04 16:17	23.5	18	658	0	23.7	23	21.4	31	22.7	24	1
2022-03-04 16:18	23.5	18	656	0	23.8	23	21.4	30	22.7	24	1
2022-03-04 16:19	23.5	18	656	0	23.8	23	21.4	29	22.7	24	1
2022-03-04 16:20	23.6	18	654	0	23.9	23	21.5	29	22.8	24	1
2022-03-04 16:21	23.6	18	652	0	23.9	23	21.5	29	22.8	24	1
2022-03-04 16:22	23.6	18	651	0	24	23	21.5	29	22.8	24	1
2022-03-04 16:23	23.7	18	651	0	24	23	21.5	29	22.8	24	1
2022-03-04 16:24	23.6	18	651	0	24	23	21.5	30	22.8	24	1
2022-03-04 16:25	23.6	18	651	0	24	24	21.6	31	22.8	24	1
2022-03-04 16:26	23.6	18	650	0	24	24	21.6	31	22.8	24	1
2022-03-04 16:27	23.6	18	650	0	24	24	21.6	32	22.8	24	1
2022-03-04 16:28	23.5	18	650	0	24	24	21.6	33	22.8	24	1
2022-03-04 16:29	23.5	18	648	0	23.9	24	21.6	33	22.8	24	1

Date and Time	Office				Master bedroom		Foyer (Entrance)		Living room		
	Temperature (°C)	RH (%)	CO2 Concentration (ppm)	Motion Sensor status	Temperature (°C)	RH (%)	Temperature (°C)	RH (%)	Temperature (°C)	RH (%)	Motion Sensor status
2022-03-04 16:30	23.5	18	647	0	23.9	24	21.6	34	22.8	25	1
2022-03-04 16:31	23.4	18	646	0	23.9	24	21.6	34	22.8	25	1
2022-03-04 16:32	23.4	18	647	0	23.9	24	21.6	35	22.8	25	1
2022-03-04 16:33	23.4	18	646	0	23.9	24	21.6	35	22.8	25	1
2022-03-04 16:34	23.4	18	646	0	23.9	24	21.7	35	22.8	25	1
2022-03-04 16:35	23.4	18	646	0	23.9	24	21.7	35	22.8	26	1
2022-03-04 16:36	23.3	18	646	0	23.9	25	21.7	36	22.8	26	1
2022-03-04 16:37	23.3	18	646	0	23.8	25	21.7	35	22.8	27	1
2022-03-04 16:38	23.3	18	646	0	23.8	25	21.7	36	22.8	27	1
2022-03-04 16:39	23.3	18	646	0	23.8	25	21.7	36	22.8	27	1
2022-03-04 16:40	23.3	18	646	0	23.8	25	21.7	34	22.8	28	1
2022-03-04 16:41	23.3	18	646	0	23.8	25	21.7	35	22.8	28	1
2022-03-04 16:42	23.3	18	646	0	23.8	25	21.7	36	22.8	28	1
2022-03-04 16:43	23.3	18	647	0	23.7	25	21.7	36	22.8	28	1
2022-03-04 16:44	23.3	18	648	0	23.7	25	21.7	36	22.8	28	1
2022-03-04 16:45	23.2	18	648	0	23.7	25	21.7	36	22.8	27	1
2022-03-04 16:46	23.2	18	647	0	23.7	25	21.6	36	22.8	27	1
2022-03-04 16:47	23.2	18	647	0	23.7	25	21.6	35	22.8	27	1
2022-03-04 16:48	23.2	18	648	0	23.7	25	21.6	35	22.8	26	1
2022-03-04 16:49	23.2	18	648	0	23.7	25	21.6	35	22.8	26	1
2022-03-04 16:50	23.2	18	648	0	23.7	25	21.6	35	22.8	27	1
2022-03-04 16:51	23.2	18	649	0	23.7	25	21.6	35	22.8	26	1
2022-03-04 16:52	23.2	18	649	0	23.6	26	21.6	35	22.8	27	1
2022-03-04 16:53	23.2	18	651	0	23.6	26	21.6	35	22.8	27	1
2022-03-04 16:54	23.2	18	651	0	23.6	26	21.6	35	22.8	26	1
2022-03-04 16:55	23.2	18	652	1	23.6	26	21.6	34	22.8	25	1
2022-03-04 16:56	23.2	18	653	1	23.6	26	21.5	33	22.8	24	N/A
2022-03-04 16:57	23.2	18	653	1	23.6	26	21.5	33	22.7	24	N/A
2022-03-04 16:58	23.2	18	670	1	23.6	25	21.5	33	22.7	24	N/A
2022-03-04 16:59	23.3	19	709	1	23.5	24	21.5	32	22.7	25	N/A
2022-03-04 17:00	23.4	19	751	1	23.5	24	21.5	32	22.7	25	N/A
2022-03-04 17:01	23.4	19	771	1	23.5	24	21.5	31	22.7	25	N/A
2022-03-04 17:02	23.5	20	783	1	23.5	24	21.5	30	22.7	25	N/A
2022-03-04 17:03	23.5	20	796	1	23.6	24	21.5	30	22.7	25	N/A
2022-03-04 17:04	23.6	20	803	1	23.7	23	21.5	30	22.7	24	N/A
2022-03-04 17:05	23.6	20	812	1	23.7	23	21.5	29	22.7	24	N/A
2022-03-04 17:06	23.7	20	835	1	23.7	23	21.5	29	22.7	24	N/A
2022-03-04 17:07	23.8	20	853	1	23.8	23	21.5	28	22.7	24	N/A
2022-03-04 17:08	23.8	20	867	1	23.8	23	21.5	28	22.8	24	N/A
2022-03-04 17:09	23.9	20	882	1	23.9	23	21.5	28	22.8	24	N/A
2022-03-04 17:10	23.9	20	895	1	23.9	23	21.6	27	22.8	24	N/A
2022-03-04 17:11	24	20	910	1	24	23	21.6	27	22.8	24	N/A
2022-03-04 17:12	24.1	21	938	1	24	23	21.6	27	22.8	24	N/A
2022-03-04 17:13	24.2	21	1051	1	24	23	21.6	28	22.8	24	N/A
2022-03-04 17:14	24.2	21	1099	1	24	23	21.6	29	22.8	24	N/A
2022-03-04 17:15	24.3	21	1083	1	24	23	21.7	30	22.8	24	N/A
2022-03-04 17:16	24.3	21	1060	1	24	23	21.7	31	22.8	24	N/A
2022-03-04 17:17	24.3	21	1027	1	24	24	21.7	31	22.8	24	N/A
2022-03-04 17:18	24.3	21	1026	1	24	24	21.7	32	22.8	24	N/A
2022-03-04 17:19	24.4	21	1036	1	24	24	21.7	33	22.8	24	N/A
2022-03-04 17:20	24.4	21	1042	1	23.9	24	21.7	33	22.8	24	N/A
2022-03-04 17:21	24.4	21	1056	1	23.9	24	21.7	33	22.8	24	N/A
2022-03-04 17:22	24.4	21	1072	1	23.9	24	21.7	34	22.8	24	N/A
2022-03-04 17:23	24.4	21	1073	1	23.9	24	21.7	34	22.8	24	N/A
2022-03-04 17:24	24.4	21	1071	1	23.9	24	21.7	34	22.8	24	N/A
2022-03-04 17:25	24.4	21	1070	1	23.8	24	21.7	35	22.8	24	N/A
2022-03-04 17:26	24.3	21	1079	1	23.8	24	21.7	35	22.8	24	N/A
2022-03-04 17:27	24.3	21	1086	1	23.8	24	21.7	35	22.8	24	N/A
2022-03-04 17:28	24.3	21	1096	1	23.8	24	21.7	35	22.8	24	N/A
2022-03-04 17:29	24.2	21	1092	1	23.7	24	21.7	35	22.8	24	N/A
2022-03-04 17:30	24.2	21	1089	1	23.7	24	21.7	36	22.8	24	N/A
2022-03-04 17:31	24.2	21	1097	1	23.7	24	21.7	36	22.8	24	N/A
2022-03-04 17:32	24.2	21	1102	1	23.7	24	21.7	36	22.8	24	N/A
2022-03-04 17:33	24.1	21	1101	1	23.7	24	21.7	36	22.8	24	N/A
2022-03-04 17:34	24.1	21	1100	1	23.7	24	21.7	36	22.7	24	N/A
2022-03-04 17:35	24.1	21	1096	1	23.7	24	21.7	36	22.7	24	N/A
2022-03-04 17:36	24.1	21	1081	1	23.7	25	21.7	36	22.7	24	N/A
2022-03-04 17:37	24.1	21	1080	1	23.6	25	21.7	36	22.7	24	N/A
2022-03-04 17:38	24.1	21	1088	1	23.6	25	21.7	36	22.7	24	N/A
2022-03-04 17:39	24.1	21	1099	1	23.6	25	21.7	36	22.7	24	N/A
2022-03-04 17:40	24.1	21	1107	1	23.6	25	21.7	36	22.7	24	N/A
2022-03-04 17:41	24.1	21	1112	1	23.6	25	21.7	35	22.7	24	N/A
2022-03-04 17:42	24.1	21	1117	1	23.5	25	21.7	35	22.7	24	N/A
2022-03-04 17:43	24.1	21	1116	0	23.5	25	21.7	35	22.7	24	1
2022-03-04 17:44	24.1	21	1131	0	23.5	25	21.7	35	22.7	24	1
2022-03-04 17:45	24.1	21	1143	0	23.5	25	21.7	36	22.7	24	1
2022-03-04 17:46	24.1	21	1142	0	23.5	24	21.7	35	22.7	24	1
2022-03-04 17:47	24	21	1134	0	23.5	24	21.6	34	22.6	25	1
2022-03-04 17:48	24	21	1127	0	23.5	24	21.6	33	22.6	24	1
2022-03-04 17:49	24	21	1085	0	23.5	24	21.7	32	22.6	24	1
2022-03-04 17:50	24	21	1043	0	23.5	24	21.7	31	22.6	24	1
2022-03-04 17:51	24	20	1017	0	23.5	23	21.7	30	22.6	24	1
2022-03-04 17:52	24	20	993	0	23.5	23	21.7	30	22.7	24	1
2022-03-04 17:53	24.1	20	969	0	23.6	23	21.7	30	22.7	24	1
2022-03-04 17:54	24.1	20	949	0	23.6	23	21.7	29	22.7	24	1
2022-03-04 17:55	24.1	20	929	0	23.7	23	21.7	29	22.7	24	1
2022-03-04 17:56	24.1	20	912	0	23.7	23	21.7	28	22.8	24	1
2022-03-04 17:57	24.2	20	896	0	23.7	23	21.8	28	22.8	25	1
2022-03-04 17:58	24.2	20	881	0	23.8	23	21.8	28	22.8	25	1
2022-03-04 17:59	24.2	20	867	0	23.8	23	21.8	28	22.8	25	1

Date and Time	Office				Master bedroom		Foyer (Entrance)		Living room		
	Temperature (°C)	RH (%)	CO2 Concentration (ppm)	Motion Sensor status	Temperature (°C)	RH (%)	Temperature (°C)	RH (%)	Temperature (°C)	RH (%)	Motion Sensor status
2022-03-04 18:00	24.3	19	858	1	23.8	23	21.8	28	22.9	25	1
2022-03-04 18:01	24.3	19	851	1	23.8	23	21.9	29	22.9	25	1
2022-03-04 18:02	24.3	19	849	1	23.8	23	21.9	30	22.9	25	1
2022-03-04 18:03	24.3	20	852	1	23.8	23	21.9	30	22.9	25	1
2022-03-04 18:04	24.3	19	857	1	23.8	23	21.9	30	22.9	25	1
2022-03-04 18:05	24.3	19	860	1	23.8	23	21.9	31	22.9	25	1
2022-03-04 18:06	24.3	19	868	1	23.8	23	21.9	31	22.9	25	1
2022-03-04 18:07	24.3	20	888	1	23.7	23	21.9	32	22.9	25	1
2022-03-04 18:08	24.3	20	899	1	23.7	23	22	32	22.9	25	1
2022-03-04 18:09	24.3	20	915	1	23.7	23	22	33	22.9	25	1
2022-03-04 18:10	24.2	21	958	0	23.7	23	22	33	22.9	25	1
2022-03-04 18:11	24.2	21	1010	0	23.7	23	22	33	22.9	25	1
2022-03-04 18:12	24.2	21	1023	0	23.6	23	22	31	22.9	25	1
2022-03-04 18:13	24.2	21	1028	0	23.6	23	22	31	22.9	25	1
2022-03-04 18:14	24.2	21	1020	0	23.6	23	22	30	22.9	25	1
2022-03-04 18:15	24.2	21	1001	0	23.6	23	22	31	22.9	25	1
2022-03-04 18:16	24.2	21	985	0	23.6	22	22	31	22.9	25	1
2022-03-04 18:17	24.2	21	969	0	23.6	22	22	29	22.9	25	1
2022-03-04 18:18	24.2	20	951	0	23.7	22	22	29	22.9	25	1
2022-03-04 18:19	24.2	20	938	0	23.7	22	22.1	30	22.9	25	1
2022-03-04 18:20	24.2	20	927	0	23.7	22	22.1	29	23	25	1
2022-03-04 18:21	24.3	20	914	0	23.8	22	22.1	28	23	25	1
2022-03-04 18:22	24.3	20	904	0	23.8	22	22.1	28	23	25	1
2022-03-04 18:23	24.3	20	894	0	23.8	22	22.1	28	23.1	25	1
2022-03-04 18:24	24.3	20	884	0	23.9	22	22.2	28	23.1	25	1
2022-03-04 18:25	24.4	20	874	0	23.9	22	22.2	28	23.1	25	1
2022-03-04 18:26	24.4	20	867	0	23.9	22	22.2	26	23.1	25	1
2022-03-04 18:27	24.4	20	860	0	24	22	22.2	26	23.2	25	1
2022-03-04 18:28	24.4	19	850	0	24	22	22.2	26	23.2	25	1
2022-03-04 18:29	24.5	19	843	0	24.1	22	22.2	26	23.2	25	1
2022-03-04 18:30	24.5	19	837	0	24.1	22	22.3	26	23.3	26	1
2022-03-04 18:31	24.5	19	832	0	24.1	22	22.3	26	23.3	25	1
2022-03-04 18:32	24.5	19	829	0	24.1	22	22.3	27	23.3	25	1
2022-03-04 18:33	24.5	19	827	0	24.1	23	22.3	28	23.3	25	1
2022-03-04 18:34	24.5	19	826	0	24.1	23	22.3	26	23.3	25	1
2022-03-04 18:35	24.4	19	825	0	24.1	23	22.3	26	23.3	25	1
2022-03-04 18:36	24.4	19	824	0	24.1	23	22.3	27	23.3	26	1
2022-03-04 18:37	24.3	19	824	0	24	23	22.3	25	23.3	26	1
2022-03-04 18:38	24.3	19	824	0	24	23	22.3	20	23.3	25	1
2022-03-04 18:39	24.3	19	820	0	24	23	22.2	23	23.3	24	1
2022-03-04 18:40	24.2	19	819	0	24	23	22.1	24	23.3	23	1
2022-03-04 18:41	24.2	19	819	0	24	23	22	25	23.3	24	1
2022-03-04 18:42	24.1	19	818	0	23.9	23	22	25	23.3	23	1
2022-03-04 18:43	24.1	20	817	0	23.9	23	22	26	23.2	24	1
2022-03-04 18:44	24.1	19	814	0	23.9	23	22	26	23.2	24	1
2022-03-04 18:45	24	19	812	0	23.9	23	22	26	23.2	25	1
2022-03-04 18:46	24	20	810	0	23.9	23	22	26	23.2	25	1
2022-03-04 18:47	24	20	808	0	23.8	23	22	27	23.2	25	1
2022-03-04 18:48	24	20	803	0	23.8	23	22	27	23.2	25	1
2022-03-04 18:49	23.9	19	802	0	23.8	23	22	27	23.2	25	1
2022-03-04 18:50	23.9	19	801	0	23.8	23	22	28	23.2	25	1
2022-03-04 18:51	23.9	19	800	0	23.8	23	22	28	23.2	25	1
2022-03-04 18:52	23.9	20	800	0	23.8	23	22	28	23.2	25	1
2022-03-04 18:53	23.9	20	800	0	23.7	23	22	28	23.2	25	1
2022-03-04 18:54	23.9	20	800	0	23.7	23	22	28	23.2	25	1
2022-03-04 18:55	23.8	20	801	0	23.7	24	22	29	23.2	25	1
2022-03-04 18:56	23.8	20	801	0	23.7	24	22	29	23.2	25	1
2022-03-04 18:57	23.8	20	799	0	23.7	24	22	30	23.2	25	1
2022-03-04 18:58	23.8	20	800	0	23.6	24	22	30	23.2	26	1
2022-03-04 18:59	23.8	20	800	0	23.6	25	22	30	23.2	26	1
2022-03-04 19:00	23.8	20	800	0	23.6	25	22	30	23.2	26	1
2022-03-04 19:01	23.8	20	800	0	23.6	25	22	30	23.2	26	1
2022-03-04 19:02	23.8	20	800	0	23.6	25	22	31	23.2	27	1
2022-03-04 19:03	23.8	20	799	0	23.5	26	22	31	23.2	27	1
2022-03-04 19:04	23.7	20	799	0	23.5	26	22	31	23.2	27	1
2022-03-04 19:05	23.7	20	799	0	23.5	26	22	31	23.2	27	1
2022-03-04 19:06	23.7	20	799	0	23.5	26	22	31	23.2	27	1
2022-03-04 19:07	23.7	20	799	0	23.5	26	22	31	23.2	27	1
2022-03-04 19:08	23.7	20	800	0	23.5	26	22	31	23.2	27	1
2022-03-04 19:09	23.7	20	799	0	23.4	25	22	30	23.2	27	1
2022-03-04 19:10	23.7	20	798	0	23.4	25	22	29	23.2	27	1
2022-03-04 19:11	23.7	20	792	0	23.4	24	22	29	23.1	28	1
2022-03-04 19:12	23.7	20	787	0	23.4	24	22	29	23.1	27	1
2022-03-04 19:13	23.7	20	777	0	23.4	24	22	28	23.2	27	1
2022-03-04 19:14	23.8	20	770	0	23.4	24	22	29	23.2	27	1
2022-03-04 19:15	23.8	19	764	0	23.4	24	22	28	23.2	27	1
2022-03-04 19:16	23.8	20	757	0	23.5	24	22	28	23.2	26	1
2022-03-04 19:17	23.9	19	753	0	23.5	24	22.1	28	23.2	26	1
2022-03-04 19:18	23.9	19	746	0	23.5	24	22.1	28	23.2	26	1
2022-03-04 19:19	23.9	19	741	0	23.6	23	22.1	27	23.3	26	1
2022-03-04 19:20	24	19	736	0	23.6	23	22.1	27	23.3	26	1
2022-03-04 19:21	24	19	732	0	23.7	23	22.2	27	23.3	26	1
2022-03-04 19:22	24.1	19	729	0	23.7	23	22.2	27	23.3	26	1
2022-03-04 19:23	24.1	19	725	0	23.7	23	22.3	27	23.4	26	1
2022-03-04 19:24	24.1	19	724	0	23.7	24	22.3	27	23.4	26	1
2022-03-04 19:25	24.1	19	723	0	23.7	24	22.3	28	23.4	26	1
2022-03-04 19:26	24.1	19	724	0	23.7	24	22.3	28	23.4	26	1
2022-03-04 19:27	24.1	19	724	0	23.7	24	22.3	28	23.4	26	1
2022-03-04 19:28	24	19	724	0	23.7	24	22.3	29	23.4	27	1
2022-03-04 19:29	24	19	724	0	23.7	24	22.3	29	23.4	27	1

Date and Time	Office				Master bedroom		Foyer (Entrance)		Living room		
	Temperature (°C)	RH (%)	CO2 Concentration (ppm)	Motion Sensor status	Temperature (°C)	RH (%)	Temperature (°C)	RH (%)	Temperature (°C)	RH (%)	Motion Sensor status
2022-03-04 19:30	24	19	722	0	23.7	24	22.4	29	23.4	27	1
2022-03-04 19:31	23.9	19	720	0	23.6	24	22.4	29	23.4	27	1
2022-03-04 19:32	23.9	19	718	0	23.6	24	22.4	30	23.4	27	1
2022-03-04 19:33	23.9	19	717	0	23.6	24	22.4	30	23.4	27	1
2022-03-04 19:34	23.8	19	716	0	23.6	24	22.4	30	23.4	27	1
2022-03-04 19:35	23.8	19	717	0	23.6	24	22.4	30	23.4	27	1
2022-03-04 19:36	23.8	19	717	0	23.6	24	22.4	31	23.4	27	1
2022-03-04 19:37	23.8	19	717	0	23.5	25	22.4	31	23.4	27	1
2022-03-04 19:38	23.7	19	717	0	23.5	25	22.4	31	23.4	27	1
2022-03-04 19:39	23.7	19	717	0	23.5	25	22.5	31	23.4	27	1
2022-03-04 19:40	23.7	19	717	0	23.5	25	22.5	31	23.4	27	1
2022-03-04 19:41	23.7	19	717	0	23.5	25	22.5	31	23.4	27	1
2022-03-04 19:42	23.7	20	717	0	23.4	25	22.5	31	23.3	27	1
2022-03-04 19:43	23.6	19	718	0	23.4	25	22.5	31	23.3	27	1
2022-03-04 19:44	23.6	20	717	0	23.4	25	22.5	31	23.3	27	1
2022-03-04 19:45	23.6	19	719	0	23.4	25	22.5	31	23.3	27	1
2022-03-04 19:46	23.6	19	721	0	23.4	25	22.5	30	23.3	27	1
2022-03-04 19:47	23.6	20	722	0	23.4	25	22.4	30	23.3	27	1
2022-03-04 19:48	23.6	20	722	0	23.3	25	22.4	30	23.3	27	1
2022-03-04 19:49	23.6	20	722	0	23.3	25	22.4	31	23.3	27	1
2022-03-04 19:50	23.6	20	722	0	23.3	25	22.4	31	23.3	27	1
2022-03-04 19:51	23.6	19	723	0	23.3	25	22.4	31	23.3	27	1
2022-03-04 19:52	23.6	20	726	1	23.3	25	22.4	31	23.3	27	1
2022-03-04 19:53	23.6	20	727	1	23.3	25	22.4	31	23.3	27	1
2022-03-04 19:54	23.5	20	738	1	23.2	25	22.4	31	23.3	27	1
2022-03-04 19:55	23.5	20	745	1	23.2	25	22.4	32	23.3	27	1
2022-03-04 19:56	23.5	20	747	1	23.2	25	22.4	32	23.3	27	1
2022-03-04 19:57	23.5	20	759	0	23.2	25	22.4	32	23.3	27	1
2022-03-04 19:58	23.5	20	765	0	23.2	25	22.4	32	23.3	27	1
2022-03-04 19:59	23.5	20	767	0	23.2	25	22.4	32	23.3	27	1
2022-03-04 20:00	23.5	20	766	0	23.2	25	22.4	32	23.3	27	1
2022-03-04 20:01	23.5	20	765	0	23.1	25	22.4	32	23.3	26	1
2022-03-04 20:02	23.4	20	765	0	23.1	25	22.4	32	23.3	27	1
2022-03-04 20:03	23.4	20	765	0	23.1	25	22.4	32	23.2	26	1
2022-03-04 20:04	23.4	20	764	0	23.1	25	22.4	32	23.2	26	1
2022-03-04 20:05	23.4	20	764	0	23.1	25	22.4	32	23.2	26	1
2022-03-04 20:06	23.4	20	764	0	23.1	25	22.4	30	23.2	27	1
2022-03-04 20:07	23.4	20	764	0	23	24	22.4	29	23.2	27	1
2022-03-04 20:08	23.4	20	758	0	23	24	22.4	29	23.3	26	1
2022-03-04 20:09	23.4	20	753	0	23	24	22.4	28	23.3	26	1
2022-03-04 20:10	23.5	20	751	0	23	24	22.4	28	23.3	26	1
2022-03-04 20:11	23.5	20	748	0	23.1	24	22.4	27	23.3	26	1
2022-03-04 20:12	23.5	20	743	0	23.1	24	22.4	27	23.3	26	1
2022-03-04 20:13	23.6	19	740	0	23.1	23	22.4	27	23.3	25	1
2022-03-04 20:14	23.6	19	735	0	23.2	23	22.5	27	23.4	26	1
2022-03-04 20:15	23.7	19	731	0	23.2	23	22.5	27	23.4	26	1
2022-03-04 20:16	23.7	19	730	0	23.2	23	22.5	26	23.4	25	1
2022-03-04 20:17	23.8	19	729	0	23.3	23	22.5	26	23.5	25	1
2022-03-04 20:18	23.8	19	727	0	23.3	23	22.6	26	23.6	25	1
2022-03-04 20:19	23.8	19	727	0	23.3	23	22.6	27	23.6	25	1
2022-03-04 20:20	23.8	19	727	0	23.4	23	22.6	27	23.6	25	1
2022-03-04 20:21	23.8	19	724	0	23.4	24	22.7	27	23.6	25	1
2022-03-04 20:22	23.8	19	724	0	23.4	24	22.7	27	23.6	25	1
2022-03-04 20:23	23.8	19	724	0	23.3	24	22.7	27	23.6	25	1
2022-03-04 20:24	23.7	19	724	0	23.3	24	22.7	27	23.6	25	1
2022-03-04 20:25	23.7	19	724	0	23.3	24	22.7	27	23.5	26	1
2022-03-04 20:26	23.7	19	724	0	23.3	24	22.7	28	23.5	26	1
2022-03-04 20:27	23.6	19	724	0	23.3	24	22.8	28	23.5	26	1
2022-03-04 20:28	23.6	19	724	0	23.3	24	22.8	28	23.5	26	1
2022-03-04 20:29	23.6	19	723	0	23.2	24	22.8	29	23.5	26	1
2022-03-04 20:30	23.6	19	723	0	23.2	24	22.8	29	23.5	26	1
2022-03-04 20:31	23.5	19	723	0	23.2	24	22.8	29	23.5	26	1
2022-03-04 20:32	23.5	19	723	0	23.2	24	22.8	29	23.5	26	1
2022-03-04 20:33	23.5	19	723	0	23.2	24	22.8	29	23.5	26	1
2022-03-04 20:34	23.5	19	722	0	23.2	25	22.8	29	23.5	26	1
2022-03-04 20:35	23.5	19	722	0	23.1	25	22.9	29	23.5	26	1
2022-03-04 20:36	23.4	19	721	0	23.1	25	22.9	29	23.5	26	1
2022-03-04 20:37	23.4	19	722	0	23.1	25	22.9	30	23.5	26	1
2022-03-04 20:38	23.4	19	722	0	23.1	25	22.9	30	23.5	26	1
2022-03-04 20:39	23.4	19	722	0	23.1	25	22.9	30	23.5	27	1
2022-03-04 20:40	23.4	19	723	0	23.1	25	22.9	30	23.5	27	1
2022-03-04 20:41	23.4	19	723	0	23	25	22.9	30	23.5	27	1
2022-03-04 20:42	23.4	19	723	0	23	25	22.9	30	23.5	27	1
2022-03-04 20:43	23.4	19	724	0	23	25	22.9	30	23.5	27	1
2022-03-04 20:44	23.3	19	726	0	23	25	22.9	30	23.5	27	1
2022-03-04 20:45	23.3	19	727	0	22.9	25	22.9	30	23.4	28	1
2022-03-04 20:46	23.3	19	728	0	22.9	25	22.9	30	23.4	27	1
2022-03-04 20:47	23.3	19	729	0	22.9	25	22.9	29	23.4	28	1
2022-03-04 20:48	23.3	19	729	0	22.9	25	22.9	29	23.4	27	1
2022-03-04 20:49	23.3	19	728	0	22.8	25	22.9	29	23.4	27	1
2022-03-04 20:50	23.3	19	729	0	22.8	25	22.9	29	23.4	27	1
2022-03-04 20:51	23.3	19	730	0	22.8	25	22.9	29	23.4	27	1
2022-03-04 20:52	23.3	19	731	0	22.8	25	22.9	29	23.4	27	1
2022-03-04 20:53	23.3	19	731	0	22.8	25	22.8	29	23.4	27	1
2022-03-04 20:54	23.2	19	731	0	22.8	25	22.8	29	23.4	28	1
2022-03-04 20:55	23.2	20	732	0	22.7	25	22.8	29	23.4	28	1
2022-03-04 20:56	23.2	19	733	0	22.7	25	22.8	29	23.4	27	1
2022-03-04 20:57	23.2	20	734	0	22.7	25	22.8	29	23.4	27	1
2022-03-04 20:58	23.2	20	734	0	22.7	25	22.8	29	23.4	27	1
2022-03-04 20:59	23.2	19	734	0	22.6	25	22.8	29	23.4	28	1

Date and Time	Office				Master bedroom		Foyer (Entrance)		Living room		
	Temperature (°C)	RH (%)	CO2 Concentration (ppm)	Motion Sensor status	Temperature (°C)	RH (%)	Temperature (°C)	RH (%)	Temperature (°C)	RH (%)	Motion Sensor status
2022-03-04 21:00	23.2	19	734	0	22.6	25	22.8	29	23.4	28	1
2022-03-04 21:01	23.2	20	735	0	22.6	25	22.8	29	23.4	28	1
2022-03-04 21:02	23.1	19	737	0	22.6	25	22.8	29	23.4	27	1
2022-03-04 21:03	23.1	20	738	0	22.6	25	22.8	29	23.3	27	1
2022-03-04 21:04	23.1	20	739	0	22.5	25	22.8	29	23.3	27	1
2022-03-04 21:05	23.1	20	740	0	22.5	25	22.8	28	23.3	27	1
2022-03-04 21:06	23.1	20	740	0	22.5	25	22.8	28	23.3	27	1
2022-03-04 21:07	23.1	20	740	0	22.5	26	22.8	28	23.3	27	1
2022-03-04 21:08	23.1	20	742	0	22.5	26	22.8	28	23.3	27	1
2022-03-04 21:09	23.1	20	743	0	22.5	26	22.7	28	23.3	27	1
2022-03-04 21:10	23.1	20	742	0	22.5	26	22.7	28	23.3	27	1
2022-03-04 21:11	23.1	20	743	0	22.5	26	22.7	28	23.3	26	1
2022-03-04 21:12	23.1	20	743	0	22.6	26	22.7	28	23.3	26	1
2022-03-04 21:13	23	20	743	0	22.6	26	22.7	28	23.3	26	1
2022-03-04 21:14	23	20	743	0	22.6	26	22.7	28	23.3	26	1
2022-03-04 21:15	23	20	744	0	22.7	26	22.7	28	23.3	26	1
2022-03-04 21:16	23	20	745	0	22.7	26	22.7	28	23.2	26	1
2022-03-04 21:17	23	20	744	0	22.7	26	22.6	28	23.2	26	1
2022-03-04 21:18	23	20	746	0	22.8	26	22.6	28	23.2	26	1
2022-03-04 21:19	23	20	747	0	22.8	26	22.6	28	23.2	26	1
2022-03-04 21:20	23	20	748	0	22.8	26	22.6	28	23.2	26	1
2022-03-04 21:21	23	20	749	0	22.9	26	22.6	28	23.2	26	1
2022-03-04 21:22	23	20	749	0	22.9	26	22.6	28	23.2	26	1
2022-03-04 21:23	23	20	749	0	23	26	22.6	28	23.2	26	1
2022-03-04 21:24	23	20	750	0	23	26	22.6	28	23.2	26	1
2022-03-04 21:25	23	20	750	0	23	26	22.6	28	23.2	26	1
2022-03-04 21:26	23	20	751	0	23.1	26	22.5	28	23.2	26	1
2022-03-04 21:27	22.9	20	751	0	23.1	26	22.5	27	23.2	26	1
2022-03-04 21:28	22.9	20	751	0	23.2	26	22.5	27	23.2	26	1
2022-03-04 21:29	22.9	20	751	0	23.2	26	22.5	27	23.1	25	1
2022-03-04 21:30	22.9	20	752	0	23.2	26	22.5	27	23.1	25	1
2022-03-04 21:31	22.9	20	751	0	23.2	26	22.5	27	23.1	25	1
2022-03-04 21:32	22.9	20	752	0	23.3	26	22.5	27	23.1	25	1
2022-03-04 21:33	22.9	20	752	0	23.3	26	22.4	27	23.1	25	1
2022-03-04 21:34	22.9	20	752	0	23.4	26	22.4	27	23.1	25	1
2022-03-04 21:35	22.9	20	753	0	23.4	26	22.4	27	23.1	25	1
2022-03-04 21:36	22.9	20	754	0	23.4	26	22.4	27	23.1	25	1
2022-03-04 21:37	22.9	20	754	0	23.5	26	22.4	27	23.1	25	1
2022-03-04 21:38	22.9	20	754	0	23.5	26	22.4	27	23.1	25	1
2022-03-04 21:39	22.8	20	755	0	23.5	26	22.4	27	23.1	25	1
2022-03-04 21:40	22.8	20	756	0	23.6	26	22.4	27	23	25	1
2022-03-04 21:41	22.8	20	757	0	23.6	26	22.3	27	23	25	1
2022-03-04 21:42	22.8	20	757	0	23.6	26	22.3	27	23	25	1
2022-03-04 21:43	22.8	20	758	0	23.7	26	22.3	27	23	25	1
2022-03-04 21:44	22.8	20	759	0	23.7	26	22.3	27	23	25	1
2022-03-04 21:45	22.8	20	759	0	23.7	26	22.3	27	23	25	1
2022-03-04 21:46	22.8	20	760	0	23.8	26	22.3	27	23	25	1
2022-03-04 21:47	22.8	20	761	0	23.8	26	22.3	27	23	25	1
2022-03-04 21:48	22.8	20	761	0	23.9	26	22.3	27	23	25	1
2022-03-04 21:49	22.8	20	760	0	23.9	26	22.3	27	23	25	1
2022-03-04 21:50	22.8	20	760	0	23.9	26	22.3	26	23	25	1
2022-03-04 21:51	22.8	20	761	0	24	26	22.3	26	23	25	1
2022-03-04 21:52	22.8	20	763	0	24	26	22.2	26	22.9	25	1
2022-03-04 21:53	22.7	20	763	0	24.1	26	22.2	26	22.9	25	1
2022-03-04 21:54	22.7	20	763	0	24.1	26	22.2	26	22.9	25	1
2022-03-04 21:55	22.7	20	763	0	24.1	26	22.2	26	22.9	25	1
2022-03-04 21:56	22.7	20	763	0	24.2	26	22.1	26	22.9	25	1
2022-03-04 21:57	22.7	20	763	0	24.2	26	22.1	26	22.9	25	1
2022-03-04 21:58	22.7	20	763	0	24.2	26	22.1	26	22.9	25	1
2022-03-04 21:59	22.7	20	764	0	24.2	26	22.1	26	22.9	26	1
2022-03-04 22:00	22.7	20	764	0	24.2	26	22.1	26	22.9	26	1
2022-03-04 22:01	22.7	20	764	0	24.2	26	22.1	26	22.9	27	1
2022-03-04 22:02	22.7	20	764	0	24.2	26	22.1	26	22.9	27	1
2022-03-04 22:03	22.7	20	765	0	24.2	26	22	26	22.9	27	1
2022-03-04 22:04	22.7	20	765	0	24.2	26	22	26	22.9	27	1
2022-03-04 22:05	22.7	20	766	0	24.2	26	22	26	22.9	27	1
2022-03-04 22:06	22.6	20	766	0	24.2	26	22	26	22.9	27	1
2022-03-04 22:07	22.6	20	766	0	24.3	26	22	26	22.9	27	1
2022-03-04 22:08	22.6	20	765	0	24.2	26	22	26	22.9	27	1
2022-03-04 22:09	22.6	20	767	0	24.3	26	22	26	22.9	27	1
2022-03-04 22:10	22.6	20	767	0	24.2	26	22	27	22.9	27	1
2022-03-04 22:11	22.6	20	767	0	24.2	26	22	27	22.9	27	1
2022-03-04 22:12	22.6	20	768	0	24.2	26	22	27	22.9	27	1
2022-03-04 22:13	22.6	20	769	0	24.2	26	22	27	22.9	27	1
2022-03-04 22:14	22.6	20	769	0	24.2	25	22	27	22.9	27	1
2022-03-04 22:15	22.6	20	768	0	24.2	24	22	27	22.9	28	1
2022-03-04 22:16	22.6	20	760	0	24.2	24	22	27	22.9	28	1
2022-03-04 22:17	22.6	20	748	0	24.2	23	22	27	22.9	28	1
2022-03-04 22:18	22.6	20	742	0	24.2	23	21.9	27	22.9	27	1
2022-03-04 22:19	22.7	19	734	0	24.2	23	22	27	22.9	27	1
2022-03-04 22:20	22.7	19	730	0	24.2	23	22	27	22.9	27	1
2022-03-04 22:21	22.8	19	725	0	24.3	23	22	27	23	27	1
2022-03-04 22:22	22.8	19	719	0	24.3	22	22	26	23	26	1
2022-03-04 22:23	22.9	19	714	0	24.3	22	22	26	23	26	1
2022-03-04 22:24	22.9	19	712	0	24.4	22	22.1	26	23	26	1
2022-03-04 22:25	23	19	705	0	24.4	22	22.1	26	23.1	26	1
2022-03-04 22:26	23	19	702	0	24.4	22	22.1	25	23.1	26	1
2022-03-04 22:27	23	19	699	0	24.5	22	22.2	25	23.1	26	1
2022-03-04 22:28	23.1	19	697	0	24.5	22	22.2	25	23.2	26	1
2022-03-04 22:29	23.1	19	695	0	24.6	22	22.3	25	23.2	26	1

Date and Time	Office				Master bedroom		Foyer (Entrance)		Living room		
	Temperature (°C)	RH (%)	CO2 Concentration (ppm)	Motion Sensor status	Temperature (°C)	RH (%)	Temperature (°C)	RH (%)	Temperature (°C)	RH (%)	Motion Sensor status
2022-03-04 22:30	23.2	19	691	0	24.6	22	22.3	25	23.2	26	1
2022-03-04 22:31	23.2	19	688	0	24.6	22	22.3	25	23.3	25	1
2022-03-04 22:32	23.2	19	686	0	24.7	21	22.3	25	23.3	25	1
2022-03-04 22:33	23.3	19	683	0	24.7	21	22.3	25	23.4	25	1
2022-03-04 22:34	23.3	19	681	0	24.8	21	22.4	25	23.4	25	1
2022-03-04 22:35	23.3	18	678	0	24.8	21	22.4	25	23.4	25	1
2022-03-04 22:36	23.4	19	677	0	24.8	21	22.5	25	23.5	25	1
2022-03-04 22:37	23.4	18	676	0	24.9	21	22.5	25	23.5	25	1
2022-03-04 22:38	23.4	18	676	0	24.9	22	22.6	25	23.5	25	1
2022-03-04 22:39	23.4	19	676	0	24.9	22	22.6	25	23.5	25	1
2022-03-04 22:40	23.3	19	677	0	24.8	22	22.6	25	23.5	25	1
2022-03-04 22:41	23.3	18	676	0	24.8	22	22.7	25	23.6	25	1
2022-03-04 22:42	23.3	18	675	0	24.8	22	22.7	25	23.6	25	1
2022-03-04 22:43	23.2	18	674	0	24.8	22	22.7	25	23.6	25	1
2022-03-04 22:44	23.2	18	672	0	24.8	22	22.8	25	23.6	25	1
2022-03-04 22:45	23.1	19	670	0	24.7	22	22.8	25	23.6	25	1
2022-03-04 22:46	23.1	19	671	0	24.7	22	22.8	25	23.6	26	1
2022-03-04 22:47	23.1	19	671	0	24.7	22	22.8	25	23.6	25	1
2022-03-04 22:48	23	19	672	0	24.7	22	22.8	26	23.6	25	1
2022-03-04 22:49	23	19	673	0	24.6	22	22.8	26	23.6	26	1
2022-03-04 22:50	23	19	673	0	24.6	22	22.8	26	23.7	26	1
2022-03-04 22:51	22.9	19	673	0	24.6	22	22.9	26	23.7	26	1
2022-03-04 22:52	22.9	19	673	0	24.6	22	22.9	26	23.7	26	1
2022-03-04 22:53	22.9	19	673	0	24.6	22	22.9	26	23.7	26	1
2022-03-04 22:54	22.9	19	672	0	24.6	22	22.9	26	23.7	26	1
2022-03-04 22:55	22.9	19	673	0	24.6	22	22.9	26	23.7	26	1
2022-03-04 22:56	22.9	19	674	0	24.5	22	22.9	26	23.7	26	1
2022-03-04 22:57	22.9	19	674	0	24.5	23	22.9	26	23.7	26	1
2022-03-04 22:58	22.9	19	674	0	24.5	23	22.9	26	23.7	25	1
2022-03-04 22:59	22.9	19	675	0	24.5	23	22.9	26	23.7	25	1
2022-03-04 23:00	22.8	19	676	0	24.4	23	22.9	26	23.7	25	1
2022-03-04 23:01	22.8	19	677	0	24.4	23	22.9	26	23.7	25	1
2022-03-04 23:02	22.8	19	677	0	24.4	23	22.9	26	23.7	25	1
2022-03-04 23:03	22.8	19	677	0	24.4	23	22.9	26	23.7	25	1
2022-03-04 23:04	22.8	19	678	0	24.3	23	22.9	26	23.7	25	1
2022-03-04 23:05	22.8	19	678	0	24.3	23	22.9	26	23.7	25	1
2022-03-04 23:06	22.8	19	678	0	24.3	23	23	26	23.7	25	1
2022-03-04 23:07	22.8	19	679	0	24.3	23	23	26	23.7	25	1
2022-03-04 23:08	22.8	19	679	0	24.3	23	23	26	23.7	25	1
2022-03-04 23:09	22.8	19	679	0	24.2	23	23	26	23.7	25	1
2022-03-04 23:10	22.8	19	680	0	24.2	23	23	26	23.7	25	1
2022-03-04 23:11	22.8	19	679	0	24.2	23	23	26	23.7	25	1
2022-03-04 23:12	22.8	19	678	0	24.2	23	22.9	26	23.7	25	1
2022-03-04 23:13	22.7	19	680	0	24.1	23	22.9	26	23.7	25	1
2022-03-04 23:14	22.7	19	680	0	24.1	23	22.9	26	23.7	25	1
2022-03-04 23:15	22.7	19	681	0	24.1	23	22.9	26	23.7	25	1
2022-03-04 23:16	22.7	19	681	0	24.1	23	22.9	26	23.7	25	1
2022-03-04 23:17	22.7	20	680	0	24	23	22.9	26	23.7	25	1
2022-03-04 23:18	22.7	20	682	0	24	23	22.9	26	23.7	25	1
2022-03-04 23:19	22.7	19	683	0	24	23	22.9	25	23.7	25	1
2022-03-04 23:20	22.7	19	683	0	24	22	22.9	25	23.7	25	1
2022-03-04 23:21	22.7	19	682	0	24	22	22.9	25	23.7	25	1
2022-03-04 23:22	22.7	19	676	0	23.9	22	22.9	25	23.7	25	1
2022-03-04 23:23	22.8	19	672	0	23.9	22	22.9	24	23.7	24	1
2022-03-04 23:24	22.8	19	668	0	23.9	22	22.9	24	23.7	24	1
2022-03-04 23:25	22.8	19	664	0	23.9	22	22.9	24	23.7	24	1
2022-03-04 23:26	22.9	19	661	0	23.9	21	22.9	24	23.7	23	1
2022-03-04 23:27	22.9	19	659	0	23.9	21	22.9	24	23.8	23	1
2022-03-04 23:28	23	19	657	0	24	21	22.9	24	23.8	23	1
2022-03-04 23:29	23	19	656	0	24	21	22.9	24	23.8	23	1
2022-03-04 23:30	23.1	18	655	0	24	21	22.9	23	23.8	23	1
2022-03-04 23:31	23.1	18	653	0	24	21	23	23	23.8	23	1
2022-03-04 23:32	23.1	18	652	0	24.1	21	23	23	23.9	23	1
2022-03-04 23:33	23.2	18	650	0	24.1	21	23	23	23.9	23	1
2022-03-04 23:34	23.2	18	647	0	24.1	21	23	23	23.9	23	1
2022-03-04 23:35	23.3	18	646	0	24.1	21	23.1	23	23.9	23	1
2022-03-04 23:36	23.3	18	645	0	24.2	21	23.1	23	23.9	23	1
2022-03-04 23:37	23.3	18	645	0	24.2	21	23.1	23	23.9	23	1
2022-03-04 23:38	23.3	18	645	0	24.2	21	23.1	23	23.9	23	1
2022-03-04 23:39	23.3	18	645	0	24.2	21	23.2	23	23.9	23	1
2022-03-04 23:40	23.2	18	645	0	24.1	21	23.2	24	23.9	23	1
2022-03-04 23:41	23.2	18	645	0	24.1	21	23.2	24	23.9	23	1
2022-03-04 23:42	23.2	18	644	0	24.1	21	23.2	24	23.9	23	1
2022-03-04 23:43	23.1	18	643	0	24.1	21	23.2	24	23.9	24	1
2022-03-04 23:44	23.1	18	642	0	24	21	23.2	24	23.9	24	1
2022-03-04 23:45	23.1	18	642	0	24	21	23.2	24	23.9	24	1
2022-03-04 23:46	23	18	642	0	24	21	23.2	24	23.9	24	1
2022-03-04 23:47	23	18	642	0	24	21	23.2	24	23.9	24	1
2022-03-04 23:48	23	18	642	0	23.9	22	23.2	24	23.9	24	1
2022-03-04 23:49	22.9	18	642	0	23.9	22	23.2	24	23.9	24	1
2022-03-04 23:50	22.9	18	643	0	23.9	22	23.2	24	23.9	24	1
2022-03-04 23:51	22.9	18	642	0	23.9	22	23.2	24	23.9	24	1
2022-03-04 23:52	22.9	18	642	0	23.8	22	23.2	24	23.9	24	1
2022-03-04 23:53	22.9	18	643	0	23.8	22	23.2	24	23.9	24	1
2022-03-04 23:54	22.9	18	643	0	23.8	22	23.2	24	23.9	24	1
2022-03-04 23:55	22.8	19	644	0	23.8	22	23.2	24	23.9	24	1
2022-03-04 23:56	22.8	19	644	0	23.8	22	23.2	24	23.9	24	1
2022-03-04 23:57	22.8	19	644	0	23.7	22	23.2	24	23.9	24	1
2022-03-04 23:58	22.8	19	645	0	23.7	22	23.2	24	23.8	24	1
2022-03-04 23:59	22.8	19	645	0	23.7	22	23.2	24	23.8	24	1