

ECE 492 - Computer Engineering Design Project

Voice Manipulator

Sean Hunter, Michael Wong, Thomas Zylstra

2013

Project Overview

The Voice Manipulator allows you to modify your voice and either send it to speakers or a Bluetooth-paired device.

It allows you to apply a frequency shift to your voice and add an echo of variable volume and delay.

The Voice Manipulator can be used in Direct Mode, in which the voice signal is sent to Line Out.

It can also be used in Bluetooth mode, in which the output is sent via Bluetooth to a paired cellular phone, effectively allowing for the Voice Manipulator to be used as a Bluetooth headset.

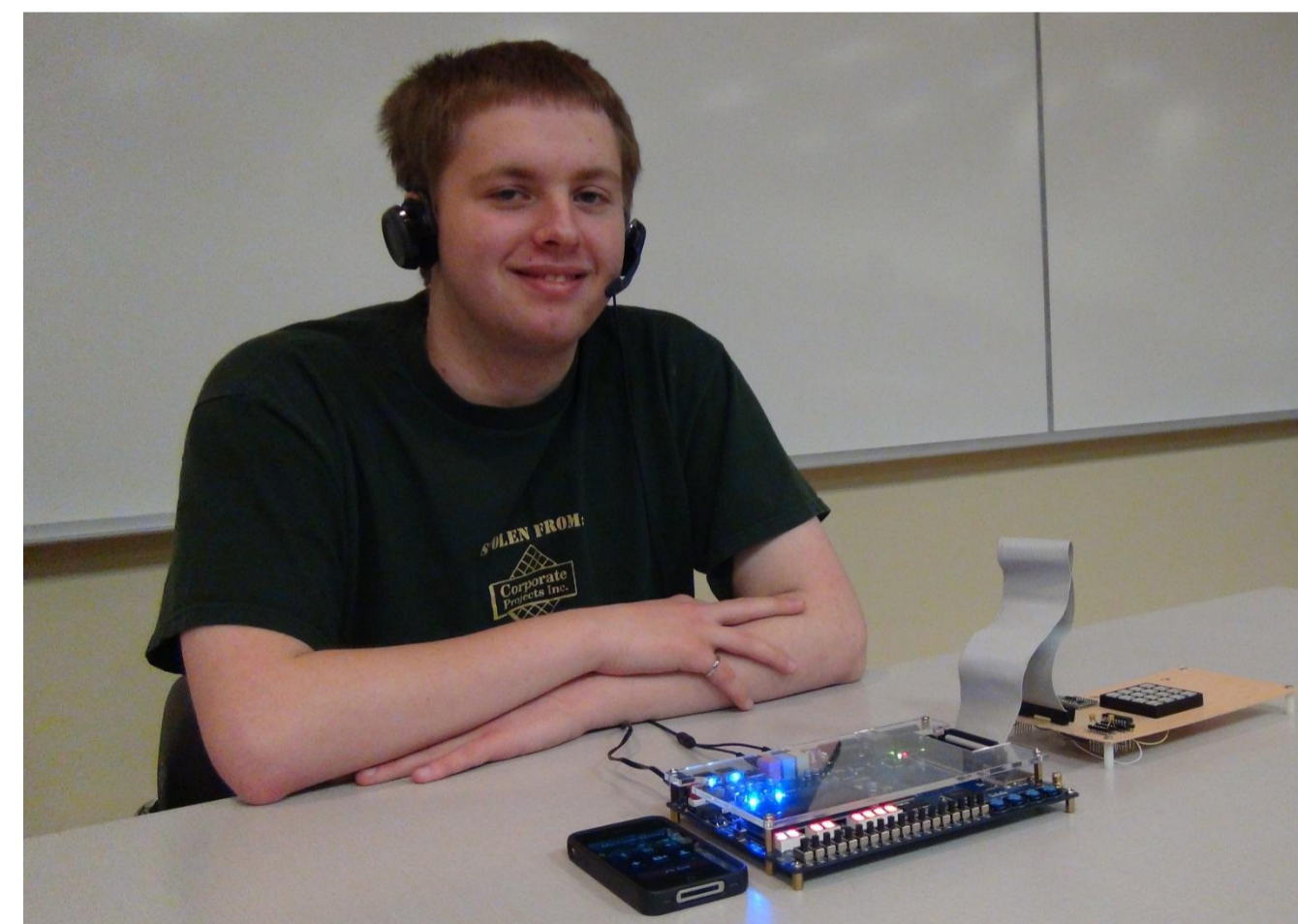

DSP Functionality

Audio data stream is routed through two DSP modules, implemented on the DE2's FPGA.

Echo Generator

- Takes two input audio signals
- Up to 0.5 seconds of input audio signal is stored in a buffer in software
- Echo Generator module is given the current audio signal and a delayed copy
- Delayed copy is made quieter via amplitude reduction if desired by the user
- Both signals are added to produce the echo

Frequency Shifter

- Single sideband modulation
- $x(t)\cos(2\pi f_c t) + H\{x(t)\}\sin(2\pi f_c t)$
- Requires the Hilbert transform, performed with a finite impulse response filter
- Original signal and Hilbert-transformed signal are multiplied by sinusoids with frequency f_c then summed
- Result is original signal shifted up by f_c

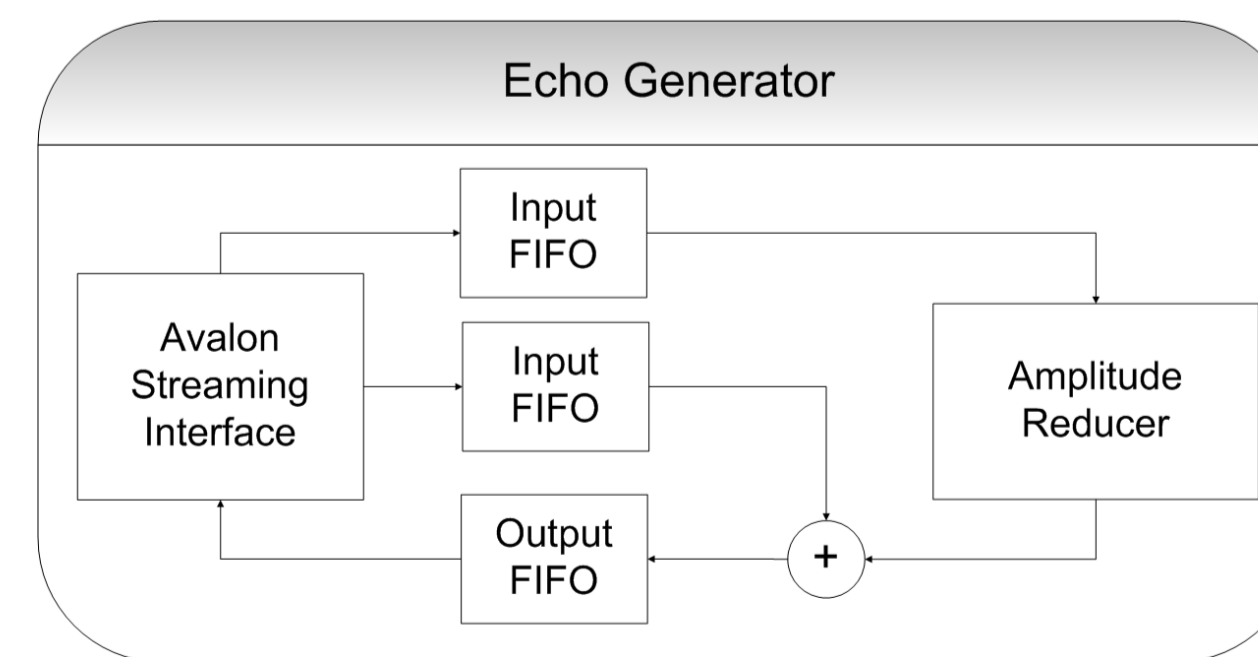
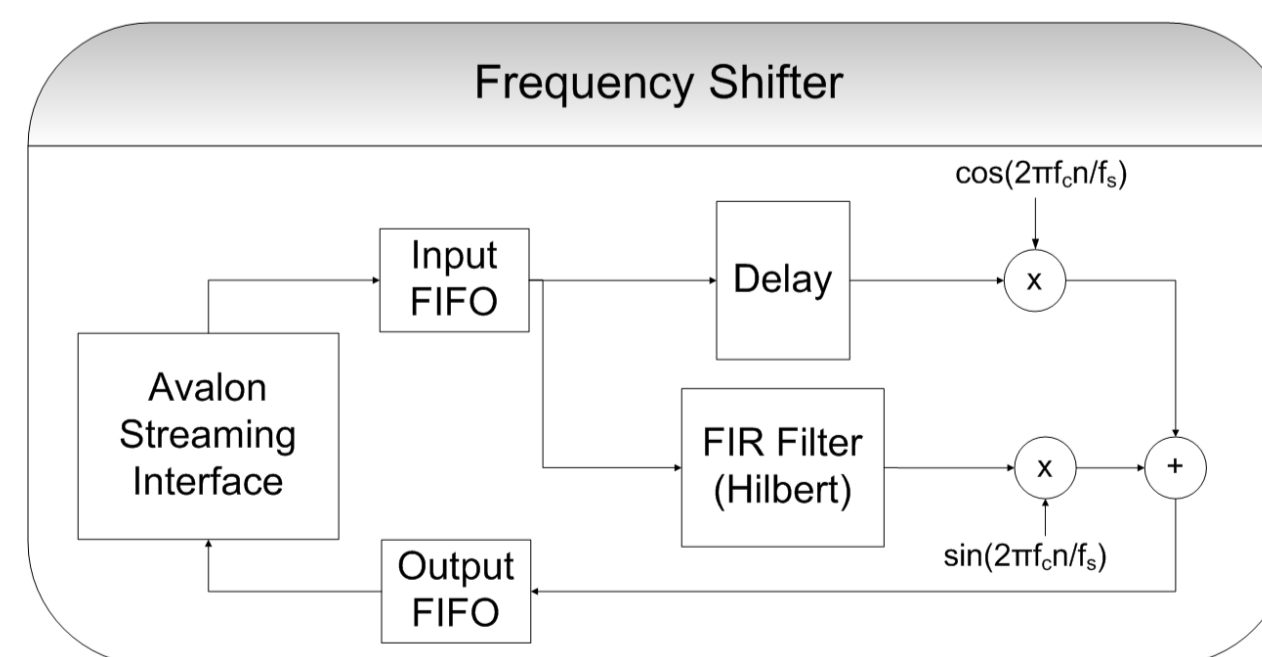
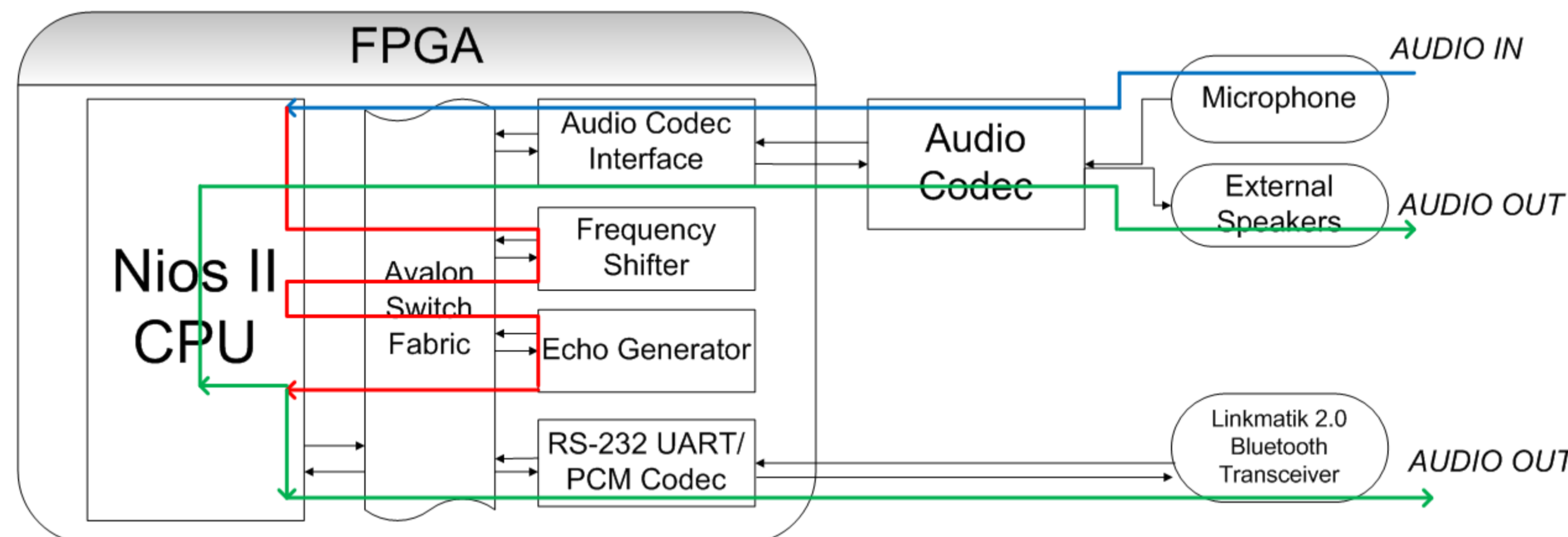

Bluetooth Connectivity

Our project uses a Flexipanel LM20 module, which contains 2 interfaces:

- Serial data interface
 - RS-232
 - Send configuration commands to module
 - Send status messages about Bluetooth link from module to board
- PCM interface
 - Communicates audio data in both directions
 - Module provides at 256kHz bit clock and an 8kHz frame synchronization signal
 - Each sample sent serially according to bit clock; each frame denoted by frame synchronization signal

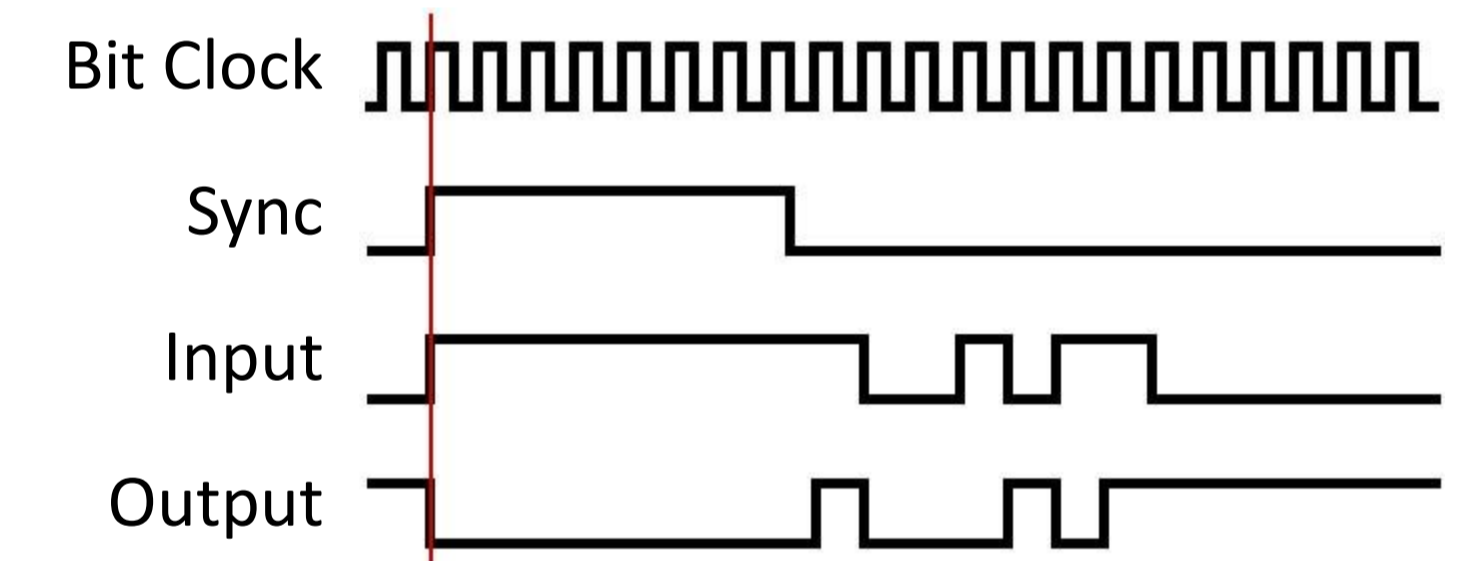

Future Work

Given additional time, we would be interested in improving the Voice Manipulator in the following ways:

- Additional DSP functionality
 - Volume levelling
 - Noise cancellation
 - True pitch shifting
- More intuitive user interface
- Expanded Bluetooth functionality
 - Ability to place calls
 - Ability to answer calls