

Chapter 7

Evolutionary Developmental Biology and the Limits of Philosophical Accounts of Mechanistic Explanation

Ingo Brigandt

Department of Philosophy, University of Alberta, 2-40 Assiniboia Hall, Edmonton, AB T6G2E7, Canada, email: brigandt@ualberta.ca

Abstract Evolutionary developmental biology (evo-devo) is considered a ‘mechanistic science,’ in that it causally explains morphological evolution in terms of changes in developmental mechanisms. Evo-devo is also an interdisciplinary and integrative approach, as its explanations use contributions from many fields and pertain to different levels of organismal organization. Philosophical accounts of mechanistic explanation are currently highly prominent, and have been particularly able to capture the integrative nature of multifield and multilevel explanations. However, I argue that evo-devo demonstrates the need for a broadened philosophical conception of mechanisms and mechanistic explanation.

Mechanistic explanation (in terms of the qualitative interactions of the structural parts of a whole) has been developed as an alternative to the traditional idea of explanation as derivation from laws or quantitative principles. Against the picture promoted by Carl Craver, that mathematical models describe but usually do not explain, my discussion of cases from the strand of evo-devo which is concerned with developmental processes points to qualitative phenomena where quantitative mathematical models are an indispensable part of the explanation. While philosophical accounts have focused on the actual organization and operation of mechanisms, properties of developmental mechanisms that are about how a mechanism reacts to modifications are of major evolutionary significance, including robustness, phenotypic plasticity, and modularity. A philosophical conception of mechanisms is needed that takes into account quantitative changes, transient entities and the generation of novel types of entities, feedback loops and complex interaction networks, emergent properties, and, in particular, functional-dynamical aspects of mechanisms, including functional (as opposed to structural) organization and distributed, system-wide phenomena. I conclude with general remarks on philosophical accounts of explanation.

Keywords evolutionary developmental biology, mechanistic explanation, mathematical models, mechanisms, scientific explanation, integration

7.1 Introduction

Evolutionary developmental biology (evo-devo) is sometimes hailed as a “mechanistic science” (Cañestro et al. 2007, p.940; Wagner et al. 2000, p.819). The notion of the “mechanistic framework of evolutionary developmental biology” (Laubichler 2010, p.208) stems from the fact that evo-devo does not just lay out phylogenetic transformation sequences of morphological characters, but offers a causal explanation of how those character transformations occurred by means of changes in developmental mechanisms. Advances in developmental genetics endow evo-devo with an enormous degree of scientific promise. Moreover, evo-devo is clearly an integrative approach, in that its explanations make reference to entities and processes on several levels of organismal organization and use contributions from several fields in an interdisciplinary fashion (Love 2013).

Multilevel and multifield explanation can be captured by current philosophical accounts of *mechanistic explanation* (Bechtel and Abrahamsen 2005), as mechanisms contain entities on several levels (where the entities stand in relations permitting systematic accounts), and different fields contribute to elucidating different components of a mechanism (Craver 2007). Thereby philosophical accounts of mechanistic explanation offer a model of epistemic integration as opposed to the traditional idea of reduction (Brigandt 2013a; Brigandt and Love 2012b; Craver 2005; Craver and Darden 2013; Darden 2005).¹ And rather than just analyzing the result of science (reductive or integrative explanations), such philosophical approaches also take into account the process of scientific research, such as the change between reductive episodes and integrative strategies (Bechtel 2010; Craver 2005).

While philosophical accounts of mechanistic explanation have been developed in the context of molecular biology, cell biology, and neuroscience (Bechtel 2006; Craver 2007; Darden 2006), evo-devo is another scientific domain exhibiting interdisciplinary research and multilevel, mechanistic explanations. However, in this chapter I argue that some aspects of evo-devo mandate a revised, broadened philosophical conception of mechanisms and mechanistic explanation. First, philosophical accounts tend to give a stereotypical portrayal of mechanisms (Machamer et al. 2000). The image conveyed is that a mechanism consists of a fixed stock of entities, it has structural parts in a spatial organization, the activities among the parts are qualitative, there is a linear causal sequence from start to termination state, and what has to be studied is the actual organization and regular operation of the mechanism. Based on my evo-devo case studies, in the concluding section I will lay out how this stereotypical construal is erroneous and what important aspects of mechanisms it omits.

¹ A complementary epistemological way of articulating integration is in terms of problem agendas that structure how contributions from different fields are to be coordinated (Brigandt 2010; Brigandt and Love 2010, 2012a; Love 2008a, 2008b).

Second, accounts of mechanistic explanation have been developed as an alternative to the covering-law model, according to which an explanation is the derivation from laws or quantitative principles. As one of the main proponents of the mechanistic approach, Carl Craver (2006, 2007, 2008) has argued that quantitative models can describe and predict, but they usually do not explain. The main part of my discussion will take issue with this, as I will point to cases where mathematical models are explanatorily indispensable. Some strands of evo-devo show it is possible to integrate mechanistic explanation (in terms of the concrete structural components of a developing organism) and mathematical modeling. This thesis is in line with William Bechtel and Adele Abrahamsen's notion of 'dynamic mechanistic explanation' (Bechtel 2011, 2013; Bechtel and Abrahamsen 2010, 2011). I improve upon previous philosophical accounts which claim that mathematical modeling plays some epistemic roles by specifically arguing that mathematical models can be indispensable in biological *explanations* (see also Baker this volume on mathematical explanations in biology). Moreover, besides the cases from chronobiology that Bechtel and Abrahamsen address, I look at evo-devo as a distinct biological domain. I have recently made analogous points in the context of systems biology (Brigandt 2013c; on systems biology and its use of molecular data and mathematical models see also Baetu this volume; Gross this volume; Isaad and Malaterre this volume; Mekios this volume; They this volume).

The following section lays out a description of evo-devo, emphasizing its interdisciplinary nature and the fact that its explanatory frameworks go beyond the study of gene regulation. Section 7.3 discusses how equations can be explanatory components of mechanistic accounts. Since mathematical models play an obvious explanatory role in evolutionary genetics, my case studies on evo-devo focus on its *developmental* aspects. It is unsurprising that an account of all quantitative aspects and the full temporal dynamics of a developmental process mandates the use of quantitative models. However, my case studies point to *qualitative* explananda where equations are still required. Section 7.4 analyzes mathematical models of the development and evolutionary origin of morphological structures. Developmental properties of major significance for morphological evolvability are robustness, phenotypic plasticity, and modularity. Section 7.5 discusses how mathematical models are involved in explanations of robustness, and prepares my point that robustness, phenotypic plasticity, and modularity go beyond the philosopher's typical focus of a mechanism's structural aspects and its actual organization and operation. The concluding section describes the broader philosophical conception of mechanisms required, and makes relevant general observations about the nature of scientific explanation.

7.2 Evolutionary developmental biology: integrative and diverse

Though evo-devo's new molecular-experimental techniques have fueled its scientific promise and prominence, it is not these new techniques which best characterize the discipline, but the intellectual problems it addresses, problems which were neglected by neo-Darwinian evolutionary theory concerned with adaptation and speciation (Love and Raff 2003). Evo-devo does not just study the evolution of developmental processes, but it addresses evolutionary questions where development is essential to the explanation. The claim is that these questions cannot be answered using a traditional framework focused on the dynamics of genes within populations (Müller and Wagner 2003; Wagner 2000).² One core item on the evo-devo agenda is the evolutionary origin of morphological novelty (Brigandt and Love 2010, 2012a; Müller and Newman 2005). An *evolutionary novelty* (or innovation) is a morphological trait that is qualitatively different from traits of ancestral lineages, which is often expressed by the definition that a novelty is a trait that is not homologous to any ancestral feature. Examples are the origin of fins in fish and—to mention a trait on a lower level of organization—the evolution of vertebrate neural crest cells, which among other things form craniofacial bone, smooth muscle, and some types of neurons, so that after its origin the neural crest came to be involved in the evolutionary modification and generation of a variety of structures. Explaining the origin of novelty involves an account of how ancestral developmental mechanisms were so modified as to give rise to a new developmental system that produces the novelty in question (Brigandt 2010).

Another related issue that evo-devo attempts to explain is morphological *evolvability* (Brigandt 2015; Hendrikse et al. 2007). Evolvability is the ability of biological systems to evolve, and a core aspect of morphological evolvability is the generation of heritable phenotypic variation on which natural selection can subsequently act (Gerhart and Kirschner 2003; Kirschner and Gerhart 1998). A key question in the study of evolvability is how a sufficient amount of *viable and functional* morphological variation could have been created so as to permit the significant morphological change that has occurred in evolution (Gerhart and Kirschner 2007; Kirschner and Gerhart 2005). One contributing factor is that organismal structures are organized as trait complexes, where individual phenotypic traits in a complex tend to change together upon mutation, e.g., the particular covariation structure among the individual traits in the mammalian skull (Jamniczky and Hallgrímsson 2011). Such an integration of individual traits permits coordinated

² "... *mechanistic* models of how developmental systems produce phenotypes and how changes within these systems contribute to corresponding changes in phenotypes. This differs from the Modern Synthesis view that evolutionary processes are driven largely by (random) genetic changes, on the one hand, and by functional interactions of organisms with their environment, on the other hand, ... What the molecular analysis of developmental processes and regulatory gene networks provides is a *mechanistic* understanding of both the development and evolution of phenotypic characters." (Laubichler 2010, pp.202 & 208, my emphasis)

change of several phenotypic traits based on a few genetic changes. The reverse situation is that some traits are uncorrelated and thus one can be modified by natural selection without impacting other traits and diminishing their fitness contribution. Even traits on different levels of organismal organization, such as developmental processes and morphological structures, can evolve independently of each other (Brigandt 2007). It is the particular mechanism of development that explains how among organisms of a species functional morphological variation can be generated, how complex traits can change in an integrated fashion, and how some traits can vary and evolve independently of each other.

Evo-devo is an integrative approach that is currently making a lot of progress, yet its future disciplinary nature is not yet settled (Brigandt and Love 2010, 2012a). Typically, evo-devo is portrayed as an emerging synthesis of evolutionary biology and developmental biology (which were unrelated for most of the 20th century), with developmental genetics creating the link. However, the label ‘synthesis’ suggests the merging of different fields into a single field. This is inconsistent with the plurality of partially independent disciplines and subdisciplines within contemporary biology. There are also open questions of how to relate evo-devo (and developmental biology) to more traditional approaches within evolutionary biology (Laubichler 2010; Wagner 2007), with some tending to describe evo-devo as an autonomous discipline that has its own questions, explanations, and methods (Hendrikse et al. 2007). In any case, one can capture evo-devo’s integrative nature by highlighting that it is an *interdisciplinary* approach (Love 2013). The complex explanatory problems it addresses require the use of ideas from many different biological disciplines (Brigandt 2010; Brigandt and Love 2012a; Love 2008a, 2008b). In addition to evolutionary genetics and developmental biology—which are explicitly noted by the notion of a synthesis of evolution and development—accounting for evolutionary novelty involves intellectual contributions from paleontology (fossil data on ancestral morphological change), phylogeny (trees of species to determine character polarity and phylogenetic junctures relevant to a character change), and morphology (composition of structures and performance of anatomical functions), among other fields. Explanatory frameworks in the context of evo-devo coordinate data, ideas, and explanatory models from a variety of fields, and evo-devo reveals its integrative potential by setting up new connections between such items of knowledge (Brigandt 2010).

Evo-devo is a diverse field including different methodological and theoretical perspectives (Brigandt 2012b; Love 2015). Though many experimentally minded evo-devo biologists may not recognize it under the ‘evo-devo’ label (Green et al. in press), there is the mathematical modelling of phenomena studied by evo-devo, and my discussion will pay particular attention to such mathematical models due to their relevance for philosophical accounts of mechanistic explanation. Evo-devo’s diversity holds even for its development component. Many studies of development focus on the regulation of individual genes (Prud’homme et al. 2011; Shigetani et al. 2002), or complete gene regulatory networks (Davidson 2006, 2010; Linksvayer et al. 2012), so that morphological evolution is conceived as

change in gene regulation (Carroll 2008; Davidson and Erwin 2006; Erwin and Davidson 2009; Laubichler 2009). However, not all explanations are restricted to developmental genetics. *Epigenetic* processes in development, and their role in morphological evolution, are often taken into account (Forgacs and Newman 2005; Hallgrímsson and Hall 2011; Hallgrímsson et al. 2007; Müller and Newman 2003; Newman and Müller 2000, 2005; Schnell et al. 2008). Though causally enmeshed with gene activity, epigenetic processes are any influences on development that do not solely depend on the expression of genes, for example biophysical interactions among cells, mechanical influences on tissues, and physical and biochemical processes of self-organization. The environment can also influence epigenetic-developmental processes (Gonzalez et al. 2011) and this is particularly important in the case of phenotypic plasticity, the ability of organisms to develop several phenotypic outcomes depending on environmental factors (Gilbert 2001; Whitman and Agrawal 2009). Phenotypic plasticity can be significant for the evolution of novel morphological traits, and shows that sometimes morphological evolution is initiated by phenotypic change, with genetic change only subsequently taking place (Palmer 2004; West-Eberhard 2003, 2005). There are also contexts in which the active behavior of an organism during its development or its adult life-time is instrumental in the evolution of novelty (Müller 2003; Palmer 2012).

Overall, evo-devo studies development and its impact on evolution in terms of the relations and interactions among entities and processes on several levels, from the molecular and cellular to the organ and whole-organism, which (apart from being interdisciplinary) is an additional way in which evo-devo's explanations are integrative. The idea championed by many of its practitioners that evo-devo is a mechanistic approach obscures that beyond explaining morphological evolution in terms of changes to developmental mechanisms, explanatory contributions from several other disciplines than developmental biology are needed, requiring scientists to take a balanced approach that does not neglect considerations about historical patterns for questions about causal processes, and that addresses both empirical and theoretical issues (Brigandt and Love 2012a). While some evo-devo biologists contrast explanation in terms of developmental mechanisms with traditional evolutionary theory's explanation in terms of the dynamics of allele frequencies within populations, there are possible connections between developmental and population processes (Rice 2008, 2012; Wagner 2007).

7.3 Explanatory relevance and how mathematical models can mechanistically explain

Philosophical accounts of mechanistic explanation have been developed as an alternative to seeing explanation as the derivation from laws (Brigandt 2013a). In molecular and experimental biology, there are hardly laws, and instead research involves breaking a whole system down into its concrete structural parts. Rather

than being able to logically deduce an explanandum from laws and other premises, explanatory understanding stems from mentally simulating how a mechanism's components are organized and interact so as to bring about the phenomenon to be explained (Bechtel and Abrahamsen 2005).

The availability of different philosophical models of explanation does not necessarily entail that explanation in terms of mechanisms and quantitative principles are incompatible. However, Rasmus Winther (2006) distinguishes between compositional biology (which produces explanations in terms of the parts of a whole) and formal biology (which explains using mathematical theories) as distinct styles of theorizing used in different fields (but see Winther 2011). As one of the main developers of accounts of mechanistic explanation, Carl Craver (2006, 2007, 2008) has gone so far as to claim that while mathematical models are widely used and indeed represent and predict, unlike mechanistic accounts they typically do not *explain*. At least, Craver contends for every mathematical model he has considered that it is merely a phenomenological model, which represents without explaining. He has illustrated his position in the case of the Hodgkin and Huxley model which describes how action potentials are generated and transmitted along the surface of neurons. As a characteristic change of a neuronal membrane's electric potential, there is a quantitative aspect to an action potential, and the original work by Hodgkin and Huxley modeled this phenomenon using equations. Yet Craver claims that the Hodgkin and Huxley model merely represented the phenomenon, and the explanation came with later research, in particular the discovery of the molecular structure and mechanistic operation of transmembrane ion channels (Craver 2006, pp.364-367; 2007, pp.54-58; for arguments that the Hodgkin and Huxley equations are explanatory see Levy 2014; Weber 2005, 2008).

Craver maintains that only causal-mechanistic accounts explain, and his vision of a mechanistic explanation involves entities, qualitative activities, and sufficient detail about their organization and physical interaction (as opposed to the representation of how a change in one entity quantitatively relates to some other, non-contiguous entity without a consideration of intermediates).

Mechanistic models are *ideally complete* when they include all of the relevant features of the mechanism, its component entities and activities, their properties, and their organization. (Craver 2006, p.367)

Complete descriptions of mechanisms exhibit productive continuity without gaps from the set up to termination conditions. (Machamer et al. 2000, p.3)

Craver's argument for his dichotomy between mechanisms and mathematical models is that since not every representation is an explanation, there have to be normative constraints on when a representation is explanatory (Craver 2006, pp.357-358). But philosophical proponents of mathematical modeling cannot provide such constraints:

My objection to the covering-law model ... is that [it is] *too weak to capture the distinctions between description and explanation*, between explanation sketches and (more) complete explanations, and between how-possibly and how-actually explanations. (Craver 2008, p.1024, my emphasis)

... the strong predictivist has difficulty expressing the explanatory limits of mere how-possibly models or theories ... that could produce the phenomenon in question but that, in fact, do not produce the phenomenon. (Kaplan and Craver 2011, pp.608-609)

Craver's (2007) mechanistic approach is able to provide constraints for when an account is explanatory. Not any physical part of a whole qualifies as a component of a mechanism; instead, on his account something is a component if it is causally relevant to the mechanism's behavior, in that changing this component would lead to a change in the mechanism's activity. To spell this out, Craver relies on James Woodward's (2003) interventionist theory of causation.

I agree that not every representation is an explanation, in fact, some mathematical models are not even meant to be explanatory. The use of models and equations serves various epistemic purposes (Bogen 2005; Weisberg 2013). Some models aim at capturing data as precisely (and simply) as possible, so as to highlight statistical trends, without the assumption that the model reflects the causal origins of the represented features. A quantitative model may be needed to represent a phenomenon that is explained by a different representation. A model may also be set up for heuristic purposes and serve theoretical discovery by revealing what (surprising) phenomena follow from assumptions that need not be realistic.

However, some mathematical models are intended to be explanatory. A clear counterexample to Craver's mechanisms/models dichotomy is systems biology, an approach that, among other things, studies molecular and cellular processes by developing mathematical models based on experimentally acquired molecular data (Baetu this volume; Boogerd et al. 2007a; Brigandt 2013c; Fagan 2012a, 2012b; Gross this volume; Isaad and Malaterre this volume; Mekios this volume; They this volume). Mathematical models can be explanatory by representing causally relevant factors. Craver's reservations about quantitative models ignores that Woodward's account of causation and causal explanation, on which Craver's mechanistic approach relies, is formulated for *quantitative generalizations*. Woodward (2003) represents putative causes as variables that may take quantitative values, and possible causal relations are equations involving variables (he includes examples from physics and economics). His central notion—to which Craver likewise appeals—is 'invariance under intervention,' as A is a cause of B only if the quantitative relation between A and B is invariant under some interventions on A . The idea is that while an intervention on A changes the value of B , the *relation* among A and B is thereby not broken. In fact, one can change B by manipulating A precisely because this causal relation is still intact. Invariant generalization is Woodward's proxy for laws of nature, as his goal is to develop an account of explanation for scientific domains where there are no laws. A universal law holds across an enormous range of conditions. A generalization between A and B may be invariant only under some small range of changes to A , but this generalization still serves the purpose of causal explanation.

Moreover, Woodward (2002) has applied his account specifically to *mechanisms*, laying out conditions "for a representation to be an acceptable model of a mechanism" (p.375). One condition is 'modularity,' the situation where one

quantitative generalization can be changed by intervention without modifying other generalizations. This condition means that different generalizations represent non-overlapping parts of an overall mechanism. While Craver (2008) complains that the proponents of mathematical models do not provide criteria for what constitutes an explanation, Woodward (2002) emphasizes that his account has normative impact. While many models in psychology (unlike in biology) may not reveal actual causes, his account specifies what would count as a cognitive mechanism.

In mathematical modeling contexts, there is a good deal of talk about making ‘predictions’ from models. The biological cases discussed in the following sections are no exception (e.g., Fisher et al. 2007; Manu et al. 2009b). While Craver tends to view prediction and explanation in opposition, in the below and many other cases where mathematical models are based on molecular data, the model and its predictions are to hold not only for the naturally occurring organism, but also for different experimental modifications to the organism, typically the phenotypes of various mutants. Since the model is meant to capture the effects of interventions on molecular components internal to the biological system modeled, the model is meant to get at causal features, so that the ‘predictive model’ is explanatory (assuming that it is fully realistic). In some cases a model-derived prediction about a novel modification to the organismal system motivates the experimental creation of a new mutant, so as to test the prediction about the intervention in turn (Herrgen et al. 2010; Manu et al. 2009b).

To Woodward’s account of when equations represent causes, I add the following considerations about *explanatory relevance*, which I discuss in more detail in Brigandt (2013c). A biological system may contain a variety of causes, and my point is that which of them are explanatorily relevant depends on the *particular explanandum* considered, and thus on the epistemic goal.

(ER) A component of an account representing causal features (including a mathematical equation) is explanatorily relevant, if omitting it or changing it results in an account from which the particular explanandum does not follow any longer. Features that are not explanatorily relevant for the explanandum at hand (and the criteria of explanatory adequacy) are to be excluded from the explanation.

By this criterion, not every quantitative detail is significant. If the explanandum can be derived not only given a mathematical model’s precise parameter values (representing the actual quantities in nature) but still follows under a range of values, what explains is the fact that the parameter values are within a particular range, since being inside vs. outside of this range makes the difference to the explanandum (Strevens 2008). But molecular-mechanistic detail can likewise be explanatorily irrelevant. Mathematical models of molecular and cellular processes may represent the relations among genes and gene products as networks, without including the structure of these molecules (network nodes) and how one molecule mechanistically affects another through intermediate steps and structural interactions (see Footnote 4 below; Bechtel this volume; Levy and Bechtel 2013). This

exclusion of detail is legitimate—and in fact mandatory—if from the structure of the network and the individual functional relations among the entities modeled the explanandum phenomenon follows.

An analogous point pertains to situations in which one does not have to reductively break down a causal factor into its lower-level components. Recently David Kaplan and Carl Craver (2011) have acknowledged that mathematical models can explain, if they represent entities and activities of mechanisms and the equations correspond to causal relation. This suggests that it is not their being mathematical that has motivated Craver's reservations about mathematical models, but that he deems most of them non-explanatory on the following (though invalid) ground:

... the variables [dynamical models] posit are not low level (e.g., neural firing rates) but, rather, macroscopic quantities at roughly the level of the cognitive performance itself ... If so, they are phenomenal models. They describe the phenomenon. They do not explain it any more than Snell's law explains refraction or the Boyle-Charles gas law explains why heat causes gases to expand. (Kaplan and Craver 2011, p.616)

This appears to confuse being explanatory and being a *reductive* explanation.³ The Boyle-Charles gas law does explain why the gas volume expanded by reference to an increase in temperature. If *A* causes *B*, then *B* can be explained in terms of *A*, regardless of whether they are on the same level. To be sure, explaining why this causal relation holds requires an appeal to lower-level entities (statistical thermodynamics in the case of why the temperature-volume relation of the Boyle-Charles law obtains). But this is a different explanandum, and if it was the explanandum Craver actually had in mind, the above quote would assert that the Boyle-Charles laws does not explain the Boyle-Charles law and Craver's challenge to mathematical models would be the trivial observation they do not explain themselves. In the case of the (non-trivial) explanandum of why the gas expanded, according to criterion *ER*, the lower-level entities should not be included as they are not explanatorily relevant in the sense of making a difference to the given explanandum (see Footnote 7). Mathematical models can legitimately abstract away from some molecular-mechanistic detail, for instance by aggregating the effects of many individual molecular events (Levy 2014). Abstraction is explanatorily virtuous, not because it makes models simpler or more general and unified (by having more concrete instances), but because upon proper abstraction a model includes precisely those factors that are relevant to the explanandum (Putnam 1975; Strevens 2008).

The lesson is that one cannot categorically say that a model is non-explanatory or—to use Craver's label—phenomenological. Models are always developed for

³ Likewise, in his argument that the Hodgkin and Huxley equations are merely phenomenological, Craver (2006) acknowledges that the equations “allow neuroscientists to predict how current will change *under various experimental interventions*” (p.363, my emphasis)—which given Woodward's interventionist account of causation entails that the equations capture some causal factors and thus explain. Craver still rules them to be non-explanatory, apparently on the grounds that they do not provide an account of how the quantitative relation is brought about by lower-level constituents.

certain epistemic purposes, and a model's explanatory credentials depend on the particular explanandum considered (and on additional standards of explanatory adequacy). In Sections 7.4 and 7.5 I use criterion *ER* to argue that for some explanations found in evo-devo equations are *indispensable*, in that without the use of any equations the explanandum phenomenon does not follow at all. As it may seem trivial that quantitative models are needed if the explanandum is the precise temporal dynamics of a system, I will point to *qualitative* explananda where quantitative equations are still needed as part of the explanans. For instance, when a qualitative phenomenon is an emergent property resulting from nonlinear interactions among the components of a system, the phenomenon cannot be anticipated by the component's qualitative interactions—on which philosophical accounts of mechanistic explanation have focused. Such a qualitative property can only be predicted and explained by citing the quantitative nonlinear interactions. (Further examples of qualitative explananda requiring equations are discussed by Brigandt 2013c in the context of systems biology.)

Given Craver's worry that too many mathematical models are merely phenomenological and black-box a system without representing its internal causal workings, I highlight that the quantitative models discussed below were developed based on molecular-mechanistic data and in many instances are tested against the properties of mutants and other experimental interventions. A mismatch between theoretical models and biological systems motivates changes of a model or further experimental investigation, so that there is interplay between molecular-experimental research and mathematical modeling (see also Baetu this volume).

7.4 Mathematical models of the origin of morphological structures

In addition to the experimental investigation of the development of morphological structures and its explanation in terms of the spatial organization and qualitative interactions among molecular and non-molecular entities, there are mathematical models of developmental processes (Morelli et al. 2012; Murray 2003; Schnell et al. 2008). Several such developmental models are relevant to evolutionary issues or explicitly meant to be evo-devo accounts, as they explain how developmental processes create phenotypic variation within a species, how developmental mechanisms can be changed so as to result in morphological change across species, and how a novel morphological structure and its underlying mode of development originated in evolution.

Many models of the temporal formation of patterns and morphological structures involve reaction-diffusion equations. These nonlinear equations are partial differential equations (representing change in both space and time) containing terms representing local chemical reactions and terms expressing the spatial diffusion of reaction products. A common version is *activator-inhibitor systems*,

which—while having two molecular entities at its core—are compatible with the situation that the entities are the products of gene activation (rather than a simple chemical reaction) and are spatially transported across cells by active mechanisms (rather than passively diffusing in a non-cellular medium). By positive feedback the activator enhances its own production—locally increasing its concentration—and it also positively regulates the inhibitor, which because of its higher diffusion rate acts in surrounding regions and there inhibits the activator. Over time this process can lead to spatial waves of substance concentrations and the formation of stable patterns, such as stripe patterns or regularly spaced spots, as seen in sea shell coloration patterns (Meinhardt 2003, 2009). As the labels ‘activator’ and ‘inhibitor’ pertain to the mutual relations between these two components, both the activator and the inhibitor may either activate or suppress downstream developmental pathways, depending on the biological case. This means that the spatial distributions of the activator and inhibitor can cause the developmental formation of morphological features (Meinhardt 2012). As first proposed by Alan Turing (1952), over most of their history reaction-diffusion systems have offered speculative, how-possibly explanations of the biological development of patterns, as the underlying molecular substances and interaction properties were unknown. But nowadays experimental evidence for the presence of activator-inhibitor systems exists, for example the interaction of pigment cells in zebrafish (Nakamasu et al. 2009), the regeneration of hair stem cells in mice and rabbits (Plikus et al. 2011), and palate growth in mice (Economou et al. 2012).

Of evolutionary significance are mathematical models of the development of mammalian teeth. The cusp number and shape of the teeth of a mammal are quite distinctive, making them a criterion for taxonomically distinguishing species. Teeth develop based on the signaling among epithelial and mesenchymal tissues, where the tooth crowns form based on a limited number of epithelial signaling centers called the enamel knots. The model of Salazar-Ciudad and Jernvall (2002) proceeds from prior experimentally generated information about the relations among several molecular components, i.e., genes producing proteins which in turn affect the expression of other genes and their products (Fig. 1A). From this causal network, a basic activator-inhibitor-system is abstracted, where in this case the activator suppresses epithelial growth and induces epithelial cells to differentiate to form an enamel knot, while the inhibitor promotes growth and represses knot differentiation (Fig. 1B).⁵ The computational model predicts the three-dimensional tooth shape and the activator and inhibitor distributions across developmental time (Fig. 1C). These predictions can be compared with empirical, in vivo data (Fig.

⁵ Note that the model abstracts away from entities mediating the interaction of the activator and inhibitor, e.g., DAN (Fig. 1A and 1B). This omitting of molecular-mechanistic detail is licit assuming that it does not alter the functional interaction and dynamics of the activator and inhibitor. If so, by my criterion *ER* such (for the target phenomenon) explanatorily irrelevant detail ought to be excluded from the explanation. This shows that a mechanistic account of *how* an effect is produced (citing all intermediate steps and structural interactions) and an explanation of *why* it occurs are consistent, but not identical.

1D). Not only does the prediction align with the developing tooth shape in mice, but the predicted activator and inhibitor distributions roughly align with the expression patterns of *p21* and *Fgf4*, respectively, seen at different developmental stages of mice and voles, which suggests that the mathematical model is realistic.

Importantly, Salazar-Ciudad and Jernvall's (2002) model is able to generate teeth with different cusp numbers, cusp positions, and overall shapes by a variation of some of the parameters, yielding clues to the developmental basis of morphological evolution across species. Salazar-Ciudad and Jernvall (2010) present an improved model, that apart from gene activation by molecular signaling, takes into account the mechanical forces that tissues exert on cells. This model is compared to empirical data in ringed seals and used to account for the large variation in tooth shape found within this species. According to these mathematical models of tooth development, large morphological differences can often be achieved by small developmental changes. This shows that the correct *mechanistic* explanation of why a tooth with a certain cusp number and position develops requires the use of a *mathematical* model with precise parameter values.

One of the best-studied cases of vertebrate morphological development is the limb skeleton, which is essential to understanding the evolutionary origin of fins in fish and their subsequent evolutionary modification, in particular the fin-to-limb transition in land-living vertebrates (Hall 2006). In addition to a plethora of fossil studies and experimental investigations in extant species (e.g., chicken), the formation of the broadest aspects of the shape of different skeletal elements and their basic spatial position has been mathematically modeled using activator-inhibitor systems (Hentschel et al. 2004; Newman et al. 2008; Newman and Müller 2005). This basic skeletal pattern in the adult organism is a fairly *qualitative* phenomenon and its developmental explanation involves quantitative models. For it needs to be understood how relatively undifferentiated tissues give rise to a highly structured pattern. The spatial pattern resulting from the operation of biological processes involving nonlinear interactions (as in the case of activator-inhibitor systems) cannot be predicted from the qualitative organization of the system's components, so that some equations are explanatorily necessary (criterion *ER* from Section 7.3).

Zhu et al. (2010) present a mathematical model of limb development which not only replicates the normal development of the basic skeletal features of the chicken wing, but also different instances of modified development, including the experimental removal of the apical ectodermal ridge (a causally crucial zone at the tip of the growing limb bud) at different points in early development, and the expansion of the early limb bud either by tissue graft or as seen in two different genetic mutants. This indicates that the mathematical model gets at some causal-mechanistic aspects of the actual phenomenon studied. In any case, the attempt to capture the effects of interventions shows that the model is meant to be explanatory (see the discussion from Section 7.3). With their model, Zhu et al. (2010) are able to generate several quite different fin skeletal patterns known only from distinct taxa of fossil fish.

Mathematical approaches of a quite different type model *genetic oscillations*, which are regularly oscillating levels of gene activity and thus of gene products. This is the molecular basis of the development of segments in vertebrates, and of relevance to an evolutionary explanation of the origin of the vertebrate body plan and the diversity of segment number in different vertebrates (30 in some fish to hundreds in snakes). In early embryonic development, these segments originate as somites, which then guide the formation of vertebrae and ribs. Crucially, somites develop in a rhythmic pattern, where one somite forms temporally after the other, from the anterior to the posterior end of the embryo, until the species-specific somite number is reached. The basic explanation of this rhythmic development of somites of equal length is the clock and wavefront model (Dequéant and Pourquié 2008; Oates et al. 2012). It involves the interaction of two processes, a segmentation clock consisting of synchronized cellular oscillations in the tissues where somites form, and a wavefront of a molecular substance moving at constant speed from anterior to posterior end (where somites yet have to form). When the wavefront passes by oscillating cells, it arrests their clock at the present stage of the cycle, so the temporal pattern of the clock is transformed into a repeated spatial molecular pattern along the anterior-posterior axis. In a nutshell, the clock determines the timing of the formation of a new somite, and the constantly moving wavefront determines the position of the somite boundaries. The length of each somite is the speed of the wavefront multiplied by the period of the clock, which is 30 minutes in zebrafish embryos (the experimentally best-studied model organism in this context) but longer in different land-living vertebrates.

In the last decade, many of the molecular components and pathways making up the wavefront mechanism and the segmentation clock have been identified by the analysis of mutants with defective segmentation, among other techniques (Dequéant and Pourquié 2008; Oates et al. 2012). Figure 2 shows major components of the segmentation clock in mice. Apart from the mechanistic interaction between the wavefront and the segmentation clock, research efforts are devoted to investigating how oscillations are mechanistically generated within each individual cell and how the oscillations are synchronized across cells by means of cell-cell signaling. Different aspects of somite formation have also been mathematically modeled (Baker and Schnell 2009; Baker et al. 2008; Mazzitello et al. 2008; Santillán and Mackey 2008).

Mathematical models that focus on oscillations within an individual cell are gene regulatory network accounts, which by means of differential equations represent the interaction among the levels of mRNAs (transcribed from oscillating genes) and of proteins (some of which are regulating gene transcription). Even the explanation of the oscillation of one such gene's activity requires a mathematical account. Take the mouse gene *Hes1*, whose oscillating transcription has been directly shown by real-time imaging studies (Masamizu et al. 2006). A non-mathematical mechanistic account can lay out the various entities involved and how they qualitatively interact with each other, e.g., whether there is positive or negative causal interaction. But this alone does not yield the phenomenon to be

explained. Figure 2 shows that the protein produced from *Hes1* in turn inhibits the transcription of *Hes1*, so as to create a negative feedback loop.⁶ Negative feedback loops are known to yield oscillations. However, whether this results in stable oscillations or damped oscillations that fade out after some while, depends on the quantitative interaction parameters, so the explanation has to include some of this quantitative detail.⁷ Moreover, the explanation has to show why—beyond the presence of one negative feedback loop—*Hes1* stably oscillates in its actual mechanistic context which includes other components influencing its transcription. Overall, the various oscillating genes of the FGF pathway and of the Notch pathway oscillate in phase, while the genes of the Wnt pathway (see Fig. 2) are in antiphase to this (Dequéant et al. 2006). This fact likewise requires explanation. The mathematical model by Goldbeter and Pourquié (2008) addresses this synchronization among the FGF, Notch, and Wnt pathways by modeling the quantitative interactions among several of the components involved.

Another important aspect of somite formation is that the oscillations of different cells are in synchrony. Notch-Delta signaling among adjacent cells is one mechanistic component underlying this, but an explanation of why synchronized oscillations occur requires a mathematical account. Mathematical models of between-cell synchronization are typically phase oscillator models. These represent each cell as one oscillator with a certain phase, so as to abstract away from the complex gene regulatory mechanism generating oscillations within the cell (which has the advantage that the many interaction values within a cell need not be experimentally known). The models mathematically study how the phases of different cells influence each other with a time-delay, showing that the coupling between adjacent cells results in overall synchrony (Morelli et al. 2009). Such mathematical modeling can accompany experimental studies of manipulated synchrony behavior, by means of changes to the timing of Delta-Notch signaling across cells (Riedel-Kruse et al. 2007). Using a phase oscillator model approach, Herrgen et al. (2010) theoretically predicted how the segmentation clock period would change in a novel zebrafish mutant. Their prediction was borne out upon creation of the mutant. It is experimentally known that the individual oscillating cells move, changing their relative position, and that synchronization across cells is recovered upon perturbations that initially destroy synchrony. Uriu et al. (2010) present a quantitative model that shows that synchronized oscillations can be maintained under random cell movement, and that such random movement in fact reduces the time needed to reestablish synchrony upon perturbation.

⁶ Fig. 2 schematically depicts the four oscillating genes *Hes1*, *Hes5*, *Hes7*, and *Hey2* (all of which engage in negative feedback) together.

⁷ Explaining why the oscillation has a period of 120 minutes (in mice) would definitely necessitate a quantitative account (see also Baetu this volume). In the related context of circadian rhythms (genetic oscillations with a period of about a day), for a philosophical account indicating the relevance of mathematical modeling see Bechtel and Abrahamsen (2010, 2011) and Bechtel (2013).

The questions of why somites of identical length develop and why stable gene activity oscillations of a regular period occur (be it within a single cell, or in synchrony across cells) are *qualitative* explananda. Knowledge of the structure of the mechanism alone, including the molecular components and their qualitative (positive or negative) interactions, is insufficient to predict that regular oscillations will in fact occur. Thus, by my criterion *ER*, the mechanistic explanation of why somites of identical length develop and of why periodical oscillations occur (in the actual, quite complex system) requires the involvement of equations laying out the quantitative and dynamic influences among the components.

7.5 How mechanisms adaptively react to modification: robustness, phenotypic plasticity, and modularity

Robustness, phenotypic plasticity, and modularity are developmental properties—an organism exhibits them because of its particular mode of development—but because of their evolutionary implications, they are highly important for evo-devo. All three properties pertain to how developmental systems adaptively react to modifications or how they permit modification while remaining functional, and thus yield morphological evolvability and provide the basis for the evolution of structural novelty (Section 7.2). In the following section, I will examine the implications of such dispositions to react to modification for philosophical conceptions of mechanisms, while the present discussion on robustness also continues the theme on the relevance of mathematical models.

Robustness is the ability of a cellular or developmental system to produce certain traits despite perturbations to the system. Robustness to non-genetic changes means that a phenotype develops regardless of certain environmental disturbances or internal developmental perturbations. Robustness to genetic changes is also possible if upon mutation the same phenotype is still present in other organisms possessing the mutation. The latter is often encountered in experimental contexts. Knockout studies, in which a particular gene is deactivated in a model organism, are conducted to trace the developmental effect of this gene. When there are good reasons to assume that a gene is part of a developmental pathway leading up to a phenotype, it comes as a surprise that the knockout hardly shows any phenotypic difference. But this is possible when the knockout organism adjusts the regulation of other genes so as to compensate for the deactivated gene.⁸

⁸ At the end of Section 7.3, I pointed out that not every explanation requires the reductive decomposition of a mechanism's components. According to my criterion *ER*, if the component is explanatorily relevant—if changing it would lead to a change in the surrounding mechanism's features to be explained—but the component's lower-level constituents are not relevant to the particular explanandum, then the explanation should cite the component but not its constituents. The component exhibiting robustness is a clear way in which this can be the case, as a change in

Robustness is of evolutionary significance for the following basic reasons (Kitano 2004; Wagner 2008). In the case of robustness to genetic modifications, some mutants will still have the same phenotype and not be removed by natural selection, so that this type of robustness leads to the accumulation of cryptic variation, i.e., genetic variation without phenotypic variation. Though it does not make any phenotypic difference for the time being, such increased genetic variation sets the stage for rapid future evolution, once the cryptic variation is uncovered by further genetic or environmental changes (Delattre and Félix 2009; Masel and Siegal 2009). Robustness to non-genetic modifications allows organisms to survive in changing environments, and is thus the product of evolution. But this ability to develop a functional phenotype in the case of environmental impact also has the side-effect that even in the case of a genetic change, the resulting phenotype is likely to be functional. The presence of such new genotypes yielding functional phenotypes—some of which may be preserved by natural selection—enables morphological evolution, in other words, evolvability (Gerhart and Kirschner 2007; Kirschner and Gerhart 2005; see also Merlin this volume).

Robustness can be found on various levels of organization, from the genetic code and the structure of RNAs and proteins, up to more complex organismal subsystems (A. Wagner 2005b; Huneman 2010; see also Breidenmoser and Wolkenhauer this volume). Individual metabolic pathways and complete metabolic networks can be robust in that the overall metabolic flux is maintained even if the reaction rate of individual enzymes is significantly decreased. With a robust gene regulatory network, the phenotypic trait (e.g., a spatial pattern of signaling molecules, eventually giving rise to anatomical structures) forms regardless of whether some of the network's genes are altered or deactivated. Robustness can result from redundancy, where two copies of a structure (e.g., a duplicated gene) are present so that the loss of one structure does not have any impact (Dean et al. 2008). Even in such cases, there often have to be functional amendments, as an active mechanism has to turn on the second gene copy which is normally not expressed (Baggs et al. 2009; Kafri et al. 2005). Often robustness is not just due to structural redundancy, but is a *distributed process* in that the overall system undergoes various functional changes to compensate for the loss of one component (Ihmels et al. 2007; A. Wagner 2005a, 2005b). A case in point is developmental regulatory networks which contain several feedback loops so as to buffer against perturbations (Li et al. 2009).

Another example is exploratory behavior, which yields robustness on several levels of organization through its ability to generate many, if not an unlimited number, of phenotypic outcome states, any of which can be physiologically stabilized if it is adaptive to the organism (Gerhart and Kirschner 2007; Kirschner and Gerhart 2005). Microtubules generate the shape of eukaryotic cells as each of the many microtubules grow and shrink in an exploratory fashion, until some of their

the component's constituents does not make a causal difference to the component's robust properties (that are relevant to the explanation).

lengths are stabilized by a signal from outside the cell. In this fashion, many cell shapes can be produced in an individual organism, permitting the remodeling of cells. The vertebrate limb consists of various skeletal elements, muscles, blood vessels, and nerves, which need to be arranged in a certain way to yield a functioning limb. This organization is not represented in some organismal blueprint; rather, it emerges by means of exploratory developmental processes, in which blood vessels and nerves grow from the body core toward the developing limb, guided by chemical signals and their surrounding milieu, with those nerves that do not find a target degenerating by cell death. Many perturbations to development will have a temporary impact, but not prevent the development of the final anatomy. Apart from illustrating that exploratory behavior robustly produces functional phenotypes by means of a distributed process, this kind of robustness to non-genetic modifications also enhances evolutionary change. The size and placement of limbs differs dramatically across vertebrates, but given the mode of limb development a *simple* genetic change to the placement of the limb is likely to yield a functioning limb with all its components properly connected, and thus a heritable, *complex* morphological change (Kirschner and Gerhart 2005).

Beyond the analysis of natural variation within a species, experimental studies offer a clear causal way to demonstrate a developmental mechanism's robustness (Baggs et al. 2009). Sometimes such experiments are very hard to conduct in higher organisms; and exhaustively showing that a mechanism is robust to changes in several components (each across a specific range) requires considering all possible component state combinations. While such a large number of modifications to a mechanism cannot be produced experimentally, a computational model of the system permits different factors to be independently varied to any quantitative degree. Apart from showing *that* a system is robust, the issue I want to emphasize is that sometimes a mathematical model is needed to explain *why* the system is robust—in line with my general thesis that equations may be needed as part of mechanistic explanations. A mechanism's robustness in some properties with respect to certain modifications can count as a *qualitative* phenomenon to be explained, at least the explanandum is not the temporal change in all of the mechanism's quantitative properties. Robustness as a distributed process can be explained only by accounting for the structural and functional organization of a larger organismal system. Some mathematical approaches attempt to infer robustness of a network from the topology of causal relations (Barabási and Oltvai 2004; Huneman 2010). In scale-free networks (where there are few nodes with many connections) the network topology is likely to be such that the system is robust to the elimination of individual nodes (Greenbury et al. 2010; Jeong et al. 2000). However, in general the biological impact of modifications cannot be inferred from gene network topology alone, so that an actual explanation of robustness involves the dynamical modeling of the perturbed mechanism's behavior based on experimental data about quantitative interactions and gene functions (Gross this volume; Siegal et al. 2007).

There are several robustness studies which integrate mathematical modeling and experimentally obtained molecular data. In various unicellular organisms whose genome has been sequenced and molecular functioning has been well-characterized, including the bacterium *Escherichia coli* and the eukaryotic yeast *Saccharomyces cerevisiae*, the robustness of metabolic networks has been mathematically modeled (Edwards and Palsson 1999, 2000a; Smart et al. 2008). Edwards and Palsson (2000b) show that the rate of two individual enzymatic reactions in *E. coli* can be reduced to 15% and 19%, respectively, of the optimal rate, without significantly diminishing the system's overall metabolic flux (if an individual reaction's rate goes below these values the system's flux drops rapidly). In contrast, for a third reaction, the threshold rate above which overall metabolic flux is largely unaffected is 70%. A quantitative explanation is required as the system's response to change (with changes to different reactions having a different impact) depends, among other things, on the quantitative rates of the various reactions in the metabolic network.

The nematode *Caenorhabditis elegans* is among the six most prominent animal model organisms in developmental biology. There are many studies pertaining to the vulva (in hermaphrodites), and its development exhibits robustness. While originally the laser ablation of individual cells was one of the primary experimental methods for investigating the causes of development and the impacts of developmental perturbations, nowadays accounts of the robustness of vulva development can rely on experimental data about molecular pathways and signaling networks (Braendle and Félix 2008; Milloz et al. 2008). Based on information about gene interactions, Fisher et al. (2007) present a mathematical model of vulva development, which is additionally validated by the subsequent experimental verification of two model-derived predictions (one about the wild-type, the other about a mutant). The computational model sheds light on the mechanistic basis of stable cell fate patterns as an instance of robust development.

In the fruit fly *Drosophila melanogaster*, many studies attempt to uncover the molecular interactions and networks underlying the formation of the basic body axes and the different body segments in early embryonic development. One case of robustness is the segment polarity network, which determines in each body segment its anterior and posterior part. The classical study by von Dassow et al. (2000) quantitatively modeled this mechanism involving 48 interaction parameters representing such features as gene transcription rates, decay rates of gene products, and the degree of cooperative interaction among entities jointly affecting gene transcription. Their analysis shows that a functional network results in about 90% of random interaction parameter value assignments, so that the mechanism is robust to a large number of modifications. More recent accounts incorporate additional molecular detail into their mathematical models to yield clues about different molecular aspects underlying the robustness of the segment polarity network (Albert and Othmer 2003; von Dassow and Odell 2002). The mathematical model of Ingolia (2004) entails that the final segment polarity gene expression pattern forms a stable steady state that is due to the presence of distinct expression states,

where each individual cell can be in one such expression state, corresponding to different cell types. Positive feedback among components—which is a qualitative, topological property of a gene regulatory network—is a necessary condition for the existence of distinct stable states. Ingolia, however, argues that positive feedback is not sufficient, as different stable states are present only if the interaction parameters satisfy certain inequalities. Thus the explanation of robustness has to include *quantitative* information about the interactions of gene network components.

A different aspect of *Drosophila* segment development are gap genes, each of which is expressed in a specific continuous region of the early embryo, where a deactivation of a gap gene results in the loss of the corresponding body segment. The mathematical model of gap gene regulation by Manu et al. (2009a, 2009b) is based on and tested by data from high precision gene expression studies. It explains the robustness of gap gene pattern formation by showing that gap gene expression patterns form dynamical attractors, i.e., quantitative states toward which the system evolves and that the system tends to occupy even if temporarily removed from such an attractor state by disturbance. (For a review of models pertaining to different aspects of *Drosophila* segmentation and spatial patterning see Umulis et al. 2008.)

Phenotypic plasticity, as the situation where different phenotypes develop in different environmental conditions for one genotype/organism, is in a sense the opposite of robustness. But in either case, the issue is the ability of a developmental system to develop a functional phenotype. Phenotypic plasticity is not just an environmental change of a passive developmental mechanism, but an adaptive response to external conditions, so that overall a developmental system can produce one phenotype despite environmental perturbations if this is the most adaptive phenotype (robustness), or it can produce different phenotypes in different conditions (plasticity). Of additional evolutionary significance is that phenotypic plasticity makes it possible for a novel phenotype to originate, not by means of genetic mutations, but through environmental changes and only subsequently being genetically stabilized. In such a case phenotypic change precedes genetic change in evolution (Palmer 2004; West-Eberhard 2003, 2005). Phenotypic changes in response to environmental circumstances concern not only physiological and behavioral traits, but even morphological structures. Vertebrate bone can change its size, shape, and density in response to frequency of use and intensity of load, so that a human's asymmetric arm use can lead to a different bone size and mineral density in the right versus left arm (as seen in tennis players), and the developed morphology of fish jaws can be contingent upon the hardness of the particular organism's diet (Müller 2003; Palmer 2012).

While these are instances of continuous phenotypic variation, there are many cases of plasticity consisting in the development of two (or more) qualitatively distinct alternative morphologies, so-called polyphenisms (Gilbert 2001; Whitman and Agrawal 2009). *Daphnia* (waterfleas) have two morphs. If they are in water containing chemicals indicating the presence of predators, juveniles develop with

a large helmet-like extension of their head and an elongated tail which makes them less likely to be swallowed by a predator. The parasitic wasp *Trichogramma semblidis* develops either of two distinct morphologies, one with, the other without wings, depending on whether it grew up inside a butterfly or alderfly host. The genetically identical individuals of insect societies can have cast-specific morphologies (e.g., soldiers and small workers) depending on how they were reared (Whitman and Agrawal 2009). Most aphids are cyclically parthenogenetic and viviparous. During the summer, females reproduce asexually and offspring develops from an unfertilized oocyte inside the mother, who gives birth to live young. After several such asexual generations, in response to environmental cues during the fall, asexual females produce sexual males and females, where sexual females make frost-resistant eggs that are fertilized by male sperm. These eggs overwinter before asexual females hatch from them in the spring. Since in asexual females the oocytes produced do not have a half set of chromosomes, which would result from the reduction division of meiosis found in sexual reproduction, there are also major differences in chromosomal and cellular activities between the sexual and asexual morphs. An interesting question arises: how, depending on the environmental cues, can two such divergent developmental programs be executed by one organismal mechanism using one genome (Davis 2012)?

The final property to be discussed is *modularity*, which is the organization of a developmental system into partially dissociated modules (Brillard this volume). These modules are moderately independent component structures or processes, such that one component can change in evolution without a change in the others, making modularity a developmental property of evolutionary significance and thus of concern to evo-devo (Callebaut and Rasskin-Gutman 2005; Schlosser and Wagner 2004). Modularity can result if the degree of functional integration (number, strength, and complexity of causal relations) within a module is greater than between modules, so that natural selection can adaptively modify one module without diminishing the functionality of others (Wagner 1996). Modules can be present at various level of organization, from gene regulatory networks and signaling pathways, to developmental processes and morphological structures (Bolker 2000; Glass and Bolker 2003; Prum 2005; von Dassow and Munro 1999). Some evo-devo discussions focus on how different modules can be rearranged so as to generate novel phenotypic outcomes, more precisely—since it is not a spatial shuffling of structures but a change in the procedural relations among developmental modules—how one module that was once causally connected with a second module becomes functionally detached from the latter and causally connected with a different module.

Some instances of modularity have a structural or simple functional basis. Multicellular organisms are spatially arranged into different cells, each of which structurally contains its own DNA, so that corresponding genes can be differentially activated in different cells, making different cell types and cellular behaviors possible. A protein may be structurally arranged so as to have two separate sites of functional interaction, so that one can be modified without the other. For example,

in allostery, the protein's active site (and the reaction it catalyzes) is distinct from its allosteric site, where effector molecules can bind so as to enable or disable the operation of the active site. In a similar vein, though triggering a complex developmental and morphological outcome, many cellular signals do not contain the information for the complex response. The signal may lead to a simple response of a receptor, as in case when the receptor either activates or deactivates a downstream developmental process, which actually embodies the complexity. As a result, a highly integrated (and internally hard to modify) developmental process can, by a change of the receptor, become tied to and activated by a quite different signal (Kirschner and Gerhart 2005). Some gene regulatory networks are arranged into separable components, such as input/output switches and plug-in subcircuits, which can be deployed in different combinations (Davidson and Erwin 2006; Erwin and Davidson 2009).

However, for evo-devo modules are not the same as the spatial parts of organisms. Rather, something is a module to the extent to which it can change independently in evolution. Modularity is not just due to an organism's structural arrangement, but due to its functional-developmental organization, where a module's partial dissociation results from the larger developmental context in which it figures (Breuker et al. 2006; Gonzalez et al. 2011; Jamniczky and Hallgrímsson 2011). The different body segments of segmented animals are structurally distinct and can evolve independently, but many developmental pathways are involved in the formation of all segments. Thus, attention to the underlying developmental process is required to understand what makes segments separate modules.

It is instructive that sometimes traits on different levels are separate modules. A morphological structure is generated by a developmental process which is orchestrated by the activity of genes. Despite the presence of such close functional and developmental connections among levels, features on different levels can evolve independently of each other. There are many instances in which a gene is involved in different developmental pathways and the formation of different morphological structures in different species, and, conversely, where the same, homologous structure develops by means of different developmental processes, from different tissues, or by the involvement of different genes in different species (Brigandt 2007; Brigandt and Griffiths 2007; Wagner and Misof 1993). A case in point is digit identity in the bird forelimb. In the hand of typical land-living vertebrates, the bones of the five digits DI to DV develop from precartilaginous cell condensations CI to CV, respectively. In the evolution of birds, two digits have been lost, where paleontological evidence indicates that the remaining digits are DI, DII, and DIII. However, developmental evidence seems to suggest that the digits of extant birds are DII, DIII, and DIV. This conflict is resolved by the hypothesis that in extant birds there remain condensations CII, CIII, and CIV, but that digits of the identity DI, DII, and DIII develop out of them—the so-called frameshift hypothesis, which is strongly supported by the current evidence (G. P. Wagner 2005; Young and Wagner 2011). In other words, while in the ancestor condensation CII developed into digit DII, CII came to develop into DI during the evolution of birds due to a

developmental frameshift, raising interesting questions of what features make such a dissociation of a developmental precursor and the structure it gives rise to mechanistically possible. Whether a developmental process and the resulting structure make up one module or are distinct modules, depends on the dynamics of an overall developmental system.

Apart from the point that mathematical models are needed to explain why a developmental mechanism is robust, this discussion has also dealt more generally with robustness, phenotypic plasticity, and modularity as they pertain to the ways developmental systems react to modifications and permit modification. In the concluding section I discuss how this goes beyond the philosophical focus on the actual organization and operation of mechanisms, and offer further considerations of what revised vision of mechanisms and mechanistic explanation is called for.

7.6 A broader philosophical conception of mechanisms and mechanistic explanation

Although some of the preceding discussion focused on the explanatory relevance of mathematical models, the examples from evo-devo I have analyzed suggest the need for a broader philosophical conception of mechanisms and mechanistic explanation more generally. The considerations I adduce may not be objectionable to philosophers, but they go beyond stereotypical philosophical portrayals of mechanisms. Apart from indicating where such stereotypical characterizations are wrong (at least for developmental processes), the aim here is to point to important aspects of biological mechanisms that philosophers have neglected, so as to lay out a more adequate account of how biologists explain using mechanisms.

While philosophers have focused on the qualitative structure of mechanism components and their qualitative interactions (e.g., binding, activating, opening), this neglects the *quantitative properties and quantitative changes* of these entities and activities. Apart from the specific reaction rates of enzymes and quantitative changes in the concentrations of various metabolites, of particular interest is that rather than just being switched on or off, a gene produces a certain copy number of its transcript per time unit, a quantitative amount that varies among cells and changes in a cell over time. Beyond the precision of cellular processes, these quantitative features are vital for the complexity of developmental processes, which is enhanced by the fact that the regulation of a single gene is often influenced by many transcription factors which interact in a cooperative fashion (Wang et al. 2009). Such synergistic interactions can transform a transcription factor concentration to gene expression rate curve that is shallow (for a single transcription factor binding) into a threshold-like curve where a quantitative difference in a cell-cell signal yields a qualitative cellular response and developmental effect. Quantitative changes of mechanism components are important to the mathematical models of structure formation and robustness discussed in Sections 7.4 and 7.5.

Simplistic portrayals suggesting that a mechanism consists of a fixed stock of entities (that move around and interact) are erroneous in that there is the *disappearance of entities and generation of novel entities*. Many molecular entities of the cell are quite *transient*, with biochemical reactions rapidly transforming one molecule into a different kind of molecule, forming complexes of several proteins, and breaking down entities into smaller molecular components.⁹ This also holds for entities on higher levels of organization. In neuronal pruning, individual synaptic connections and axons are removed. Whole cells disappear due to apoptosis, i.e., controlled cell death in which the cell systematically disassembles itself and its remaining fragments are removed by the immune system. Chunks of tissue can disappear based on apoptosis, a process which is instrumental for the formation of morphological structures in normal development. For example, in the limbs of land-living vertebrates, the different digits form by the removal of soft tissue in between the forming digits (Abud 2004). The pathological death of cells and tissues occurs in autoimmune and neurodegenerative diseases. Of particular relevance in our context is the generation of new entities, in fact, of new *types* of entities. New cell types are generated by means of differentiation. During ontogeny (developmental time), tissues, morphological structures and organs are formed that the developing organism did not previously possess. Evo-devo likewise studies the phylogenetic origin of novel structures (not present in ancestral species) in the course of evolutionary time. Although such higher-level entities originate by changes to lower-level entities, the generation of new types of entities has to be a solid ingredient of any philosophical conception of mechanisms, given that the formation of new structures in development and evolution is a major explanatory target for developmental biology and evo-devo, respectively.

When the operation of a mechanism is described as consisting of “regular changes from start or set-up to finish or termination conditions,” where “what makes [the mechanism] regular is the productive continuity between stages ... represented schematically by $A \rightarrow B \rightarrow C$ ” (Machamer et al. 2000, p.3), such a stereotypical characterization creates the impression that every mechanism consists in a single causal sequence. Yet causal pathways may branch or merge, and in fact form *complex networks* of causal interactions among components. This is reflected by biologists stating that they study ‘gene regulatory networks’ and by the recent terminological shifts from ‘metabolic pathway’ to ‘metabolic network’ and from ‘signaling pathway’ to ‘signaling network.’ Researchers emphasize that since there is ‘cross-talk’ between what used to be considered separate pathways, the larger network needs to be studied (Barabási et al. 2011; Fraser and Germain 2009; Jørgensen and Linding 2010; Layek et al. 2011; Wing et al. 2011). Moreover, the organization of causal interactions is not unidirectional and acyclic, but mechanisms have *feedback loops* (Bechtel 2011). This complex causal structure of

⁹ Baetu (this volume) points out that the functioning of a mechanism can be due not so much due to stable entities, but by a stable concentration (of a type of entity), where individual entities are very short-lived and constantly replaced.

mechanisms (the topology of functional relations) needs to be taken into account because it is vital for the mechanism's actual behavior and the higher-level properties it generates. The case of the generation of synchronized oscillations across cells as the molecular basis of vertebrate segment formation (Section 7.4) and the robustness in gene regulatory network activity (Section 7.5) illustrate this point.

Related to the generation of novel entities, another relevant aspect of mechanisms is *emergence* (Bedau 2003; Boogerd et al. 2005; Huneman 2012; Mitchell 2012). I do not require a strong ontological type of emergence to be tied to the concept of a mechanism. Rather, I use emergence to refer to situations in which some of a system's qualitative properties can only be predicted if the full system dynamics are simulated, or more loosely, if qualitative properties cannot be foreseen from the system's components and their basic interactions. For example, bistability occurs when a subsystem is in either of two distinct states (though switching from one to the other state is possible), so that continuous processes and the components' quantitative interactions yield some discontinuous and qualitatively different properties (Eissing et al. 2004; Ferrell and Xiong 2001; Goldbeter et al. 2007). The presence of distinct *Drosophila* segment polarity gene expression patterns corresponding to different cell types, mentioned in Section 7.5, is an instance of bistability (Ingolia 2004). In Brigandt (2013c), I discuss spontaneous symmetry-breaking, which occurs when extremely small stochastic fluctuations in a system eventually lead to the crossing of a threshold that determines which of two branches of a bifurcation (in possible states of the system) is taken. Found also in molecular and cellular biology contexts, spontaneous symmetry-breaking makes it possible for a nearly homogeneous state to give rise to a distinct and stable structural pattern.

Emergent properties can result from nonlinear interactions among mechanism components combined with the presence of a complex organization with feedback loops (Bhalla and Iyengar 1999). Emergence even in the above weak sense is scientifically important because it entails the need to study the mechanism's complete organization, not just its structural, but also its functional organization. Moreover, while the operation and resulting features of some mechanisms represented by diagrams can be understood by means of mental simulation, complex mechanisms with feedback loops or nonlinear interactions require a mathematical treatment (Boogerd et al. 2007b; Brigandt 2013c; Ihekwaba et al. 2005; Noble 2002; Westerhoff and Kell 2007).

The discussion so far about the appropriate ontological construal of a mechanism has already relied on scientifically, and thus epistemically, important aspects of mechanisms. Now I comment explicitly on the epistemological issue of *mechanistic explanation*. Philosophers typically assume that a mechanistic account explains in terms of the mechanism's structural components, the component's spatial organization, and their qualitative interactions. Carl Craver (2006, 2007, 2008) has promoted the picture that unlike mechanistic accounts in this sense, mathematical models describe but typically do not explain. In contrast, in Section 7.3 I laid out a criterion for equations being indispensable components of an explanation and ap-

plied it in Sections 7.4 and 7.5 to different cases from evo-devo, arguing that there are even *qualitative* explananda about developmental mechanisms where quantitative models are a necessary part of the explanans (see also Brigandt 2013c). Overall, mathematical modeling is needed for two related reasons. First, according to criterion *ER*, if omitting or changing a feature results in the explanandum not following any longer, this feature is explanatorily indispensable—and thus has to be *included in the explanatory model*. And some such features can only be mathematically represented or are even quantitative. In some cases the mathematical model may represent qualitative relations of the molecular entities involved, e.g., the topology of a complex network showing positive or negative regulatory influence among components. However, if the property of the system to be explained is sensitive to quantitative parameters, a quantitative model is explanatorily indispensable (Sections 7.3 and 7.4 mentioned instances of this). Second, beyond a model representing different components of a mechanism and their organization, the explanation has to show *how (or at least that) the explanandum results* from this. If the mechanism's operation cannot be understood by mental simulation, a mathematical analysis of the model or a computer simulation is needed.

My examples illustrate that some studies in developmental biology and evo-devo integrate concrete molecular knowledge gained from experiments with mathematical modeling. As a result, mechanistic explanations can—and sometimes must, depending on the explanandum—include *quantitative considerations and mathematical models* (see also Baetu this volume; though Gross this volume, Isaad and Malaterre this volume, and They this volume analyze the differences between mechanistic explanation and explanations using mathematical models). I have focused on the developmental prong of evo-devo, as developmental mechanisms pertain to molecular and experimental biology for which philosophical accounts of mechanisms are meant to hold. For a full picture of explanation in evo-devo (regardless of whether all aspects qualify as mechanistic explanation), one needs to bear in mind that developmental processes are not the only features of evo-devo. Other explanatory contributions are involved, including phylogenetic trees, historical patterns of change in morphological structures, considerations about natural selection (e.g., organism-environment and organism-organism interactions),¹⁰ and the dynamics of genotype and phenotype distributions within populations. In the latter case, mathematical models from population genetics, quantita-

¹⁰ There is disagreement on whether philosophical accounts of mechanisms can capture natural selection (Barros 2008; Skipper and Millstein 2005). My view is that explanations in terms of natural selection (in particular when using mathematical models) abstract away from many concrete properties and activities of individual organism. But abstraction from mechanistic detail happens even in mathematical models in molecular and developmental biology (Section 7.3; Bechtel this volume; Brigandt 2013c; Levy 2014; Levy and Bechtel 2013), so that the broad conception of mechanistic explanation advocated here is more likely to accommodate natural selection. One difficulty is that natural selection is about fitness *differences* among phenotypes. Even if each of two phenotypes is part of a mechanism (by each phenotype being possessed by concrete organisms), what matters is how the phenotypes differ and the phenotypes' differential behavior across time, which is a complex and unusual aspect of a 'mechanism.'

tive genetics, and evolutionary ecology can be components of evo-devo explanations (Rice 2008, 2012).

My discussion has highlighted the *functional aspects of mechanisms*, for instance in the contexts of robustness, phenotypic plasticity, and modularity. Such properties go beyond spatial organization on which many philosophical discussions have centered. The functional organization of a mechanism need not align with its structural organization, as shown by the case of modularity. It may be easy to recognize the structures involved in a developmental process, but something is a module to the extent to which it can be modified or rearranged in morphological evolution. While there are clear developmental-functional connections between genes and anatomical structures (as structures on different levels of organization), these functional relations can sometimes be rearranged so that genes and anatomical structures evolve independently of each other. As a result, modularity can be a very complex kind of organization determined by an organism's developmental-functional dynamics. Functionality can also be *distributed* across a mechanism, so that beyond local interactions the system has global causal properties.¹¹ A mechanism may be robust in maintaining one component while another component is modified, but this potential may not just reside in the relations among a few components but in a more system-wide response (Section 7.5; Mitchell 2009). Phenotypic plasticity is likewise due to the functioning of larger developmental processes. While modularity means that two components are sufficiently developmentally dissociated (to be able to be rearranged in evolution), a look at the larger functional context may be required to account for why this dissociation exists.

Philosophical accounts have emphasized the actual organization and the actual, regular operation of a mechanism, given that a how-possibly mechanism postulated does not in fact explain (Craver 2006, 2007). But robustness, phenotypic plasticity, and modularity pertain to the *mechanism's modified organization and modified operation*. For these are dispositional properties of how a developmental mechanism reacts to perturbations or permits modification. In evo-devo explanations of why a developmental process exhibits robustness, phenotypic plasticity, or modularity, the very explanandum is the response to a mechanism's modification—so that there are important scientific questions that are not just about the actual behavior of a mechanism, but also its dispositions.

Section 7.5 indicated why these dispositional aspects of developmental mechanisms are scientifically important by discussing how robustness, phenotypic plasticity, and modularity increase morphological evolvability and the potential for the generation of structural novelty. Now I emphasize this issue again by tying it to intelligent design ideas against evolution (Brigandt 2013b). According to Michael Behe (1996), a biological system is irreducibly complex when the removal of any part leads to the system ceasing to function (the alleged implication being that such a system cannot have evolved gradually but must have originated with all

¹¹ On related grounds, Baetu (this volume) argues that molecular mechanisms are not neatly individuated objects.

parts in place). This is actually a resurrection of Paley's (1802) watchmaker argument, though Behe claims irreducible complexity of molecular systems. But robustness is the very opposite of irreducible complexity. The prevalence of robustness shows that organisms are not like Paley's watch which breaks down upon modification (Kirschner and Gerhart 2005). In contrast to the machine and artifact metaphors that intelligent design creationists use to portray cells and organisms, developmental systems are highly flexible. The flexibility of developmental mechanisms is also of evolutionary significance, and since biologists have it in view, flexibility and active response to perturbations must be part of philosophical conceptions of mechanisms.

Let me conclude with some general remarks on scientific explanation (see also Brigandt 2013c). Evo-devo shows that not only is each explanatory account a work in progress with new contributions constantly being added, but explanatory accounts are so complex that they do not consist in and *cannot be captured by a single representation* (O'Malley et al. 2014). Accounts of morphological evolvability and the evolutionary origin of novelty coordinate a plethora of descriptions, explanatory ideas, and models. Such individual representations come from different biological fields, pertain to different levels of organization, focus on organismal structure or address function, consist in qualitative-mechanistic accounts or quantitative models, provide empirical data or theoretical models, and address change in developmental time or change in evolutionary time. To reflect this complexity, it is better to speak of an explanatory *account or framework* than one explanation. While past philosophical theories such as the deductive-nomological model (Hempel and Oppenheim 1948) attempted to characterize a scientific explanation by laying out conditions for what makes a set of statements an explanans, no such simple philosophical account is possible.

In the last three decades there has been a laudable trend in philosophy of science to not just studying the *content* and results of science, but also the *practice* and changing activities of scientists (Brigandt 2013a, 2013b). In the present context, beyond analyzing explanatory theories, this involves philosophically studying how scientists develop and use explanations. Accounts of mechanistic explanation are already tied to the process of discovery by paying attention to the discovery of mechanisms and the shifts between reductive research episodes and integrative strategies (Bechtel 2006, 2010; Craver 2005; Craver and Darden 2013; Darden 2006). In my argument that some mathematical models are explanatory, I have heeded Carl Craver's admonition that not every representation is an explanation. However, one also has to point out that a single model can be used for both explanatory purposes and non-explanatory purposes (describing a phenomenon, predicting to test a hypothesis, exploring conceptual possibilities) depending on the context.¹² Likewise, in their research geared toward the generation of an explana-

¹² Baetu (this volume) discusses how a mathematical model can reveal a previous molecular-mechanistic account to be explanatorily incomplete. This can prompt and guide further experimental discovery, so a mathematical model can be involved in both discovery and explanation.

tory account, scientists make use of many representations, some of which are non-explanatory. Since in scientific practice, explanations and other representations are jointly used (guided by epistemic aims and values; Brigandt 2012a, 2013a), philosophical theories of explanation have to be related to other epistemological notions, including description, prediction, model, standard, and method. Since the scientific activity of explaining is related to such other activities as predicting, confirming, modeling, and choosing theoretical and experimental strategies, isolated philosophical accounts of discovery, confirmation, and explanation are impossible.

Acknowledgments I am indebted to Pierre-Alain Braillard, Christophe Malaterre, and two anonymous referees for detailed comments on an earlier version of this paper. I thank Emma Kennedy for proofreading the manuscript and Arnon Levy, Bill Bechtel, Carl Craver, and Maureen O'Malley for discussions on mechanistic explanation and mathematical models. Figure 1 was reprinted from Salazar-Ciudad and Jernvall (2002) with the permission of the copyright holder, the National Academy of Sciences, USA. Figure 2 was reprinted from Dequéant and Pourquié (2008) by permission from Macmillan Publishers Ltd.

References

- Abud, H. E. 2004. Shaping developing tissues by apoptosis. *Cell Death & Differentiation* 11:797-799.
- Albert, R., and H. G. Othmer. 2003. The topology of the regulatory interactions predicts the expression pattern of the segment polarity genes in *Drosophila melanogaster*. *Journal of Theoretical Biology* 223:1-18.
- Baetu, T. this volume. From mechanisms to mathematical models and back to mechanisms: Quantitative mechanistic explanations. In *Explanation in biology: An enquiry into the diversity of explanatory patterns in the life sciences*, eds. P.-A. Braillard and C. Malaterre. Berlin: Springer.
- Baggs, J. E., T. S. Price, L. DiTacchio, S. Panda, G. A. FitzGerald, and J. B. Hogenesch. 2009. Network features of the mammalian circadian clock. *PLoS Biology* 7:e1000052.
- Baker, A. this volume. Mathematical explanation in biology. In *Explanation in biology: An enquiry into the diversity of explanatory patterns in the life sciences*, eds. P.-A. Braillard and C. Malaterre. Berlin: Springer.
- Baker, R. E., and S. Schnell. 2009. How can mathematics help us explore vertebrate segmentation? *HFSP Journal* 3:1-5.
- Baker, R. E., S. Schnell, and P. K. Maini. 2008. Mathematical models for somite formation. In *Multiscale modeling of developmental systems*, eds. S. Schnell, P. K. Maini, S. A. Newman, and T. J. Newman, 183-203. New York: Academic Press.
- Barabási, A.-L., N. Gulbahce, and J. Loscalzo. 2011. Network medicine: A network-based approach to human disease. *Nature Reviews Genetics* 12:56-68.
- Barabási, A.-L., and Z. N. Oltvai. 2004. Network biology: Understanding the cell's functional organization. *Nature Reviews Genetics* 5:101-113.
- Barros, D. B. 2008. Natural selection as a mechanism. *Philosophy of Science* 75:306-322.
- Bechtel, W. 2006. *Discovering cell mechanisms: The creation of modern cell biology*. Cambridge: Cambridge University Press.
- Bechtel, W. 2010. The downs and ups of mechanistic research: Circadian rhythm research as an exemplar. *Erkenntnis* 73:313-328.

- Bechtel, W. 2011. Mechanism and biological explanation. *Philosophy of Science* 78:533-557.
- Bechtel, W. 2013. From molecules to behavior and the clinic: Integration in chronobiology. *Studies in History and Philosophy of Biological and Biomedical Sciences* 44: 493-502.
- Bechtel, W. this volume. Graph-theoretic perspectives on dynamic mechanistic explanation. In *Explanation in biology: An enquiry into the diversity of explanatory patterns in the life sciences*, eds. P.-A. Braillard and C. Malaterre. Berlin: Springer.
- Bechtel, W., and A. Abrahamsen. 2005. Explanation: A mechanist alternative. *Studies in History and Philosophy of Biological and Biomedical Sciences* 36:421-441.
- Bechtel, W., and A. Abrahamsen. 2010. Dynamic mechanistic explanation: Computational modeling of circadian rhythms as an exemplar for cognitive science. *Studies In History and Philosophy of Science Part A* 41:321-333.
- Bechtel, W., and A. Abrahamsen. 2011. Complex biological mechanisms: Cyclic, oscillatory, and autonomous. In *Philosophy of complex systems*, ed. C. Hooker, 257-285. Amsterdam: Elsevier.
- Bedau, M. A. 2003. Downward causation and the autonomy of weak emergence. *Principia* 3:5-50.
- Behe, M. J. 1996. *Darwin's black box: The biochemical challenge to evolution*. New York: Free Press.
- Bhalla, U. S., and R. Iyengar. 1999. Emergent properties of networks of biological signaling pathways. *Science* 283:381-387.
- Bogen, J. 2005. Regularities and causality; generalizations and causal explanations. *Studies in History and Philosophy of Biological and Biomedical Sciences* 36:397-420.
- Bolker, J. A. 2000. Modularity in development and why it matters to evo-devo. *American Zoologist* 40:770-776.
- Boogerd, F. C., F. Bruggeman, R. Richardson, A. Stephan, and H. Westerhoff. 2005. Emergence and its place in nature: A case study of biochemical networks. *Synthese* 145:131-164.
- Boogerd, F. C., F. J. Bruggeman, J.-H. S. Hofmeyr, and H. V. Westerhoff. eds. 2007a. *Systems biology: Philosophical foundations*. Amsterdam: Elsevier.
- Boogerd, F. C., F. J. Bruggeman, J.-H. S. Hofmeyr, and H. V. Westerhoff. 2007b. Towards philosophical foundations of Systems Biology: Introduction. In *Systems biology: Philosophical foundations*, eds. F. C. Boogerd, F. J. Bruggeman, J.-H. S. Hofmeyr, and H. V. Westerhoff, 3-19. Amsterdam: Elsevier.
- Braendle, C., and M.-A. Félix. 2008. Plasticity and errors of a robust developmental system in different environments. *Developmental Cell* 15:714-724.
- Braillard, P.-A. this volume. Prospect and limits of explaining biological systems in engineering terms. In *Explanation in biology: An enquiry into the diversity of explanatory patterns in the life sciences*, eds. P.-A. Braillard and C. Malaterre. Berlin: Springer.
- Breidenmoser, T., and O. Wolkenhauer. this volume. Explanation in systems biology. In *Explanation in biology: An enquiry into the diversity of explanatory patterns in the life sciences*, eds. P.-A. Braillard and C. Malaterre. Berlin: Springer.
- Breuker, C. J., V. Debat, and C. P. Klingenberg. 2006. Functional evo-devo. *Trends in Ecology and Evolution* 21:488-492.
- Brigandt, I. 2007. Typology now: Homology and developmental constraints explain evolvability. *Biology and Philosophy* 22:709-725.
- Brigandt, I. 2010. Beyond reduction and pluralism: Toward an epistemology of explanatory integration in biology. *Erkenntnis* 73:295-311.
- Brigandt, I. 2012a. The dynamics of scientific concepts: The relevance of epistemic aims and values. In *Scientific concepts and investigative practice*, eds. U. Feest and F. Steinle, 75-103. Berlin: de Gruyter.
- Brigandt, I. ed. 2012b. *Perspectives on evolutionary novelty and evo-devo*. Special issue of the *Journal of Experimental Zoology Part B: Molecular and Developmental Evolution* (Volume 318, Issue 6).

- Brigandt, I. 2013a. Explanation in biology: Reduction, pluralism, and explanatory aims. *Science & Education* 22:69-91.
- Brigandt, I. 2013b. Intelligent design and the nature of science: Philosophical and pedagogical points. In *The Philosophy of Biology: A Companion for Educators*, ed. K. Kampourakis, 205-238. Dordrecht: Springer.
- Brigandt, I. 2013c. Systems biology and the integration of mechanistic explanation and mathematical explanation. *Studies in History and Philosophy of Biological and Biomedical Sciences* 44:477-492.
- Brigandt, I. 2015. From developmental constraint to evolvability: How concepts figure in explanation and disciplinary identity. In *Conceptual change in biology: Scientific and philosophical perspectives on evolution and development*, ed. A. C. Love, 305-325. Dordrecht: Springer.
- Brigandt, I., and P. E. Griffiths. 2007. The importance of homology for biology and philosophy. *Biology and Philosophy* 22:633-641.
- Brigandt, I., and A. C. Love. 2010. Evolutionary novelty and the evo-devo synthesis: Field notes. *Evolutionary Biology* 37:93-99.
- Brigandt, I., and A. C. Love. 2012a. Conceptualizing evolutionary novelty: Moving beyond definitional debates. *Journal of Experimental Zoology Part B: Molecular and Developmental Evolution* 318:417-427.
- Brigandt, I., and A. C. Love. 2012b. Reductionism in biology. In *The Stanford Encyclopedia of Philosophy*, ed. E. N. Zalta. <http://plato.stanford.edu/entries/reduction-biology>
- Callebaut, W., and D. Rasskin-Gutman. eds. 2005. *Modularity: Understanding the development and evolution of natural complex systems*. Cambridge, MA: MIT Press.
- Cañestro, C., H. Yokoi, and J. H. Postlethwait. 2007. Evolutionary developmental biology and genomics. *Nature Reviews Genetics* 8:932-942.
- Carroll, S. B. 2008. Evo-devo and an expanding evolutionary synthesis: A genetic theory of morphological evolution. *Cell* 134:25-36.
- Craver, C. F. 2005. Beyond reduction: Mechanisms, multifield integration and the unity of neuroscience. *Studies in the History and Philosophy of Biological and Biomedical Sciences* 36:373-395.
- Craver, C. F. 2006. When mechanistic models explain. *Synthese* 153:355-376.
- Craver, C. F. 2007. *Explaining the brain: Mechanisms and the mosaic unity of neuroscience*. Oxford: Oxford University Press.
- Craver, C. F. 2008. Physical law and mechanistic explanation in the Hodgkin and Huxley model of the action potential. *Philosophy of Science* 75:1022-1033.
- Craver, C. F., and L. Darden. 2013. *In search of mechanisms: Discoveries across the life sciences*. Chicago: University of Chicago Press.
- Darden, L. 2005. Relations among fields: Mendelian, cytological and molecular mechanisms. *Studies in History and Philosophy of Biological and Biomedical Sciences* 36:349-371.
- Darden, L. 2006. *Reasoning in biological discoveries: Essays on mechanisms, interfield relations, and anomaly resolution*. Cambridge: Cambridge University Press.
- Davidson, E. H. 2006. *The regulatory genome: Gene regulatory networks in development and evolution*. London: Academic Press.
- Davidson, E. H. 2010. Emerging properties of animal gene regulatory networks. *Nature* 468:911-920.
- Davidson, E. H., and D. H. Erwin. 2006. Gene regulatory networks and the evolution of animal body plans. *Science* 311:796-800.
- Davis, G. K. 2012. Cyclical parthenogenesis and viviparity in aphids as evolutionary novelties. *Journal of Experimental Zoology Part B: Molecular and Developmental Evolution* 318:448-459.
- Dean, E. J., J. C. Davis, R. W. Davis, and D. A. Petrov. 2008. Pervasive and persistent redundancy among duplicated genes in yeast. *PLoS Genetics* 4:e1000113.

- Delattre, M., and M.-A. Félix. 2009. The evolutionary context of robust and redundant cell biological mechanisms. *BioEssays* 31:537-545.
- Dequéant, M.-L., E. Glynn, K. Gaudenz, M. Wahl, J. Chen, A. Mushegian, and O. Pourquié. 2006. A complex oscillating network of signaling genes underlies the mouse segmentation clock. *Science* 314:1595-1598.
- Dequéant, M.-L., and O. Pourquié. 2008. Segmental patterning of the vertebrate embryonic axis. *Nature Reviews Genetics* 9:370-382.
- Economou, A. D., A. Ohazama, T. Porntaveetus, P. T. Sharpe, S. Kondo, M. A. Basson, A. Gritli-Linde, M. T. Cobourne, and J. B. A. Green. 2012. Periodic stripe formation by a Turing mechanism operating at growth zones in the mammalian palate. *Nature Genetics* 44:348-351.
- Edwards, J. S., and B. O. Palsson. 1999. Systems properties of the *Haemophilus influenzae* Rd metabolic genotype. *Journal of Biological Chemistry* 274:17410-17416.
- Edwards, J. S., and B. O. Palsson. 2000a. The *Escherichia coli* MG1655 in silico metabolic genotype: Its definition, characteristics, and capabilities. *Proceedings of the National Academy of Sciences USA* 97:5528-5533.
- Edwards, J. S., and B. O. Palsson. 2000b. Robustness analysis of the *Escherichia coli* metabolic network. *Biotechnology Progress* 16:927-939.
- Eissing, T., H. Conzelmann, E. D. Gilles, F. Allgöwer, E. Bullinger, and P. Scheurich. 2004. Bistability analyses of a caspase activation model for receptor-induced apoptosis. *Journal of Biological Chemistry* 279:36892-36897.
- Erwin, D. H., and E. H. Davidson. 2009. The evolution of hierarchical gene regulatory networks. *Nature Reviews Genetics* 10:141-148.
- Fagan, M. B. 2012a. *Materia mathematica: Models in stem cell biology*. *Journal of Experimental & Theoretical Artificial Intelligence* 24:315-327.
- Fagan, M. B. 2012b. Waddington redux: Models and explanation in stem cell and systems biology. *Biology and Philosophy* 27:179-213.
- Ferrell, J. E., and W. Xiong. 2001. Bistability in cell signaling: How to make continuous processes discontinuous, and reversible processes irreversible. *Chaos* 11:227-236.
- Fisher, J., N. Piterman, A. Hajnal, and T. A. Henzinger. 2007. Predictive modeling of signaling crosstalk during *C. elegans* vulval development. *PLoS Computational Biology* 3:e92.
- Forgacs, G., and S. A. Newman. 2005. *Biological physics of the developing embryo*. Cambridge: Cambridge University Press.
- Fraser, I. D. C., and R. N. Germain. 2009. Navigating the network: Signaling cross-talk in hematopoietic cells. *Nature Immunology* 10:327-331.
- Gerhart, J. C., and M. W. Kirschner. 2003. Evolvability. In *Keywords and concepts in evolutionary developmental biology*, eds. B. K. Hall and W. M. Olson, 133-137. Cambridge, MA: Harvard University Press.
- Gerhart, J. C., and M. W. Kirschner. 2007. The theory of facilitated variation. *Proceedings of the National Academy of Sciences USA* 104:8582-8589.
- Gilbert, S. F. 2001. Ecological developmental biology: Developmental biology meets the real world. *Developmental Biology* 233:1-12.
- Glass, G. L., and J. A. Bolker. 2003. Modularity. In *Keywords and concepts in evolutionary developmental biology*, eds. B. K. Hall and W. M. Olson, 260-267. Cambridge, MA: Harvard University Press.
- Goldbeter, A., D. Gonze, and O. Pourquié. 2007. Sharp developmental thresholds defined through bistability by antagonistic gradients of retinoic acid and FGF signaling. *Developmental Dynamics* 236:1495-1508.
- Goldbeter, A., and O. Pourquié. 2008. Modeling the segmentation clock as a network of coupled oscillations in the Notch, Wnt and FGF signaling pathways. *Journal of Theoretical Biology* 252:574-585.
- Gonzalez, P. N., E. E. Oyhenart, and B. Hallgrímsson. 2011. Effects of environmental perturbations during postnatal development on the phenotypic integration of the skull. *Journal of Experimental Zoology Part B: Molecular and Developmental Evolution* 316B:547-561.

- Green, S., M. Fagan, and J. Jaeger. in press. Explanatory integration challenges in evolutionary systems biology. *Biological Theory*. doi:10.1007/s13752-014-0185-8
- Greenbury, S. F., I. G. Johnston, M. A. Smith, J. P. K. Doye, and A. A. Louis. 2010. The effect of scale-free topology on the robustness and evolvability of genetic regulatory networks. *Journal of Theoretical Biology* 267:48-61.
- Gross, F. this volume. The relevance of irrelevance: Explanation in systems biology. In *Explanation in biology: An enquiry into the diversity of explanatory patterns in the life sciences*, eds. P.-A. Braillard and C. Malaterre. Berlin: Springer.
- Hall, B. K. ed. 2006. *Fins into limbs: Evolution, development and transformation*. Chicago: University of Chicago Press.
- Hallgrímsson, B., and B. K. Hall. eds. 2011. *Epigenetics: Linking genotype and phenotype in development and evolution*. Berkeley: University of California Press.
- Hallgrímsson, B., D. E. Lieberman, W. Liu, A. F. Ford-Hutchinson, and F. R. Jirik. 2007. Epigenetic interactions and the structure of phenotypic variation in the cranium. *Evolution & Development* 9:76-91.
- Hempel, C. G., and P. Oppenheim. 1948. Studies in the logic of explanation. *Philosophy of Science* 15:135-175.
- Hendrikse, J. L., T. E. Parsons, and B. Hallgrímsson. 2007. Evolvability as the proper focus of evolutionary developmental biology. *Evolution & Development* 9:393-401.
- Hentschel, H. G. E., T. Glimm, J. A. Glazier, and S. A. Newman. 2004. Dynamical mechanisms for skeletal pattern formation in the vertebrate limb. *Proceedings of the Royal Society of London. Series B: Biological Sciences* 271:1713-1722.
- Herrgen, L., S. Ares, L. G. Morelli, C. Schröter, F. Jülicher, and A. C. Oates. 2010. Intercellular coupling regulates the period of the segmentation clock. *Current Biology* 20:1244-1253.
- Huneman, P. 2010. Topological explanations and robustness in biological sciences. *Synthese* 177:213-245
- Huneman, P. 2012. Determinism, predictability and open-ended evolution: Lessons from computational emergence. *Synthese* 185:195-214.
- Ihekwaba, A. E. C., D. S. Broomhead, R. Grimley, N. Benson, M. R. H. White, and D. B. Kell. 2005. Synergistic control of oscillations in the nf-kb signalling pathway. *IEE Proceedings Systems Biology* 152:153-160.
- Ihmels, J., S. R. Collins, M. Schuldiner, N. J. Krogan, and J. S. Weissman. 2007. Backup without redundancy: Genetic interactions reveal the cost of duplicate gene loss. *Molecular Systems Biology* 3.
- Ingolia, N. T. 2004. Topology and robustness in the *Drosophila* segment polarity network. *PLoS Biology* 2:e123.
- Issad, T., and C. Malaterre. this volume. Are dynamic mechanistic explanations still mechanistic? In *Explanation in biology: An enquiry into the diversity of explanatory patterns in the life sciences*, eds. P.-A. Braillard and C. Malaterre. Berlin: Springer.
- Jamniczky, H. A., and B. Hallgrímsson. 2011. Modularity in the skull and cranial vasculature of laboratory mice: Implications for the evolution of complex phenotypes. *Evolution & Development* 13:28-37.
- Jeong, H., B. Tombor, R. Albert, Z. N. Oltvai, and A. L. Barabási. 2000. The large-scale organization of metabolic networks. *Nature* 407:651-654.
- Jørgensen, C., and R. Linding. 2010. Simplistic pathways or complex networks? *Current Opinion in Genetics & Development* 20:15-22.
- Kafri, R., A. Bar-Even, and Y. Pilpel. 2005. Transcription control reprogramming in genetic backup circuits. *Nature Genetics* 37:295-299.
- Kaplan, D. M., and C. F. Craver. 2011. The explanatory force of dynamical and mathematical models in neuroscience: A mechanistic perspective. *Philosophy of Science* 78:601-627.
- Kirschner, M. W., and J. C. Gerhart. 1998. Evolvability. *Proceedings of the National Academy of Sciences USA* 95:8420-8427.

- Kirschner, M. W., and J. C. Gerhart. 2005. *The plausibility of life: Resolving Darwin's dilemma*. New Haven: Yale University Press.
- Kitano, H. 2004. Biological robustness. *Nature Reviews Genetics* 5:826-837.
- Laubichler, M. D. 2009. Form and function in Evo Devo: Historical and conceptual reflections. In *Form and function in developmental evolution*, eds. M. D. Laubichler and J. Maienschein, 10-46. Cambridge: Cambridge University Press.
- Laubichler, M. D. 2010. Evolutionary developmental biology offers a significant challenge to the neo-Darwinian paradigm. In *Contemporary debates in the philosophy of biology*, eds. F. Ayala and R. Arp, 199-212. Malden: Wiley-Blackwell.
- Layek, R. K., A. Datta, and E. R. Dougherty. 2011. From biological pathways to regulatory networks. *Molecular BioSystems* 7:843-851.
- Levy, A. 2014. What was Hodgkin and Huxley's achievement? *British Journal for the Philosophy of Science* 65:469-492.
- Levy, A., and W. Bechtel. 2013. Abstraction and the organization of mechanisms. *Philosophy of Science* 80:241-261.
- Li, X., J. J. Cassidy, C. A. Reinke, S. Fischboeck, and R. W. Carthew. 2009. A microRNA imparts robustness against environmental fluctuation during development. *Cell* 137:273-282.
- Linksvayer, T. A., J. H. Fewell, J. Gadau, and M. D. Laubichler. 2012. Developmental evolution in social insects: Regulatory networks from genes to societies. *Journal of Experimental Zoology Part B: Molecular and Developmental Evolution* 318:159-169.
- Love, A. C. 2008a. Explaining evolutionary innovations and novelties: Criteria of explanatory adequacy and epistemological prerequisites. *Philosophy of Science* 75:874-886.
- Love, A. C. 2008b. From philosophy to science (to natural philosophy): Evolutionary developmental perspectives. *The Quarterly Review of Biology* 83:65-76.
- Love, A. C. 2013. Interdisciplinary lessons for the teaching of biology from the practice of evo-devo. *Science & Education* 22:255-278.
- Love, A. C. ed. 2015. *Conceptual change in biology: Scientific and philosophical perspectives on evolution and development*. Berlin: Springer.
- Love, A. C., and R. A. Raff. 2003. Knowing your ancestors: Themes in the history of evo-devo. *Evolution & Development* 5:327-330.
- Machamer, P., L. Darden, and C. F. Craver. 2000. Thinking about mechanisms. *Philosophy of Science* 67:1-25.
- Manu, S. Surkova, A. V. Spirov, V. V. Gursky, H. Janssens, A.-R. Kim, O. Radulescu et al. 2009a. Canalization of gene expression and domain shifts in the *Drosophila* blastoderm by dynamical attractors. *PLoS Computational Biology* 5:e1000303.
- Manu, S. Surkova, A. V. Spirov, V. V. Gursky, H. Janssens, A.-R. Kim, O. Radulescu et al. 2009b. Canalization of gene expression in the *Drosophila* blastoderm by gap gene cross regulation. *PLoS Biology* 7:e1000049.
- Masamizu, Y., T. Ohtsuka, Y. Takashima, H. Nagahara, Y. Takenaka, K. Yoshikawa, H. Okamura, and R. Kageyama. 2006. Real-time imaging of the somite segmentation clock: Revelation of unstable oscillators in the individual presomitic mesoderm cells. *Proceedings of the National Academy of Sciences USA* 103:1313-1318.
- Masel, J., and M. L. Siegal. 2009. Robustness: Mechanisms and consequences. *Trends in Genetics* 25:395-403.
- Mazzitello, K. I., C. M. Arizmendi, and H. G. E. Hentschel. 2008. Converting genetic network oscillations into somite spatial patterns. *Physical Review E* 78:021906.
- Meinhardt, H. 2003. Complex pattern formation by a self-destabilization of established patterns: Chemotactic orientation and phyllotaxis as examples. *Comptes Rendus Biologies* 326:223-237.
- Meinhardt, H. 2009. *The algorithmic beauty of sea shells*. 4th edition. Berlin: Springer.
- Meinhardt, H. 2012. Modeling pattern formation in hydra: A route to understanding essential steps in development. *International Journal of Developmental Biology* 56:447-462.

- Mekios, C. this volume. Explanation in systems biology: Is it all about mechanisms? In *Explanation in biology: An enquiry into the diversity of explanatory patterns in the life sciences*, eds. P.-A. Braillard and C. Malaterre. Berlin: Springer.
- Merlin, F. this volume. Developmental noise: explaining the specific heterogeneity of individual organisms. In *Explanation in biology: An enquiry into the diversity of explanatory patterns in the life sciences*, eds. P.-A. Braillard and C. Malaterre. Berlin: Springer.
- Milloz, J., F. Duveau, I. Nuez, and M.-A. Félix. 2008. Intraspecific evolution of the intercellular signaling network underlying a robust developmental system. *Genes & Development* 22:3064-3075.
- Mitchell, S. D. 2009. *Unsimple truths: Science, complexity, and policy*. Chicago: University of Chicago Press.
- Mitchell, S. D. 2012. Emergence: Logical, functional and dynamical. *Synthese* 185:171-186.
- Morelli, L. G., S. Ares, L. Herrgen, C. Schröter, F. Jülicher, and A. C. Oates. 2009. Delayed coupling theory of vertebrate segmentation. *HFSP Journal* 3:55-66.
- Morelli, L. G., K. Uriu, S. Ares, and A. C. Oates. 2012. Computational approaches to developmental patterning. *Science* 336:187-191.
- Müller, G. B. 2003. Embryonic motility: Environmental influences and evolutionary innovation. *Evolution & Development* 5:56-60.
- Müller, G. B., and S. A. Newman. eds. 2003. *Origination of organismal form: Beyond the gene in developmental and evolutionary biology*. Cambridge, MA: MIT Press.
- Müller, G. B., and S. A. Newman. 2005. The innovation triad: An EvoDevo agenda. *Journal of Experimental Zoology Part B: Molecular and Developmental Evolution* 304B:487-503.
- Müller, G. B., and G. P. Wagner. 2003. Innovation. In *Keywords and concepts in evolutionary developmental biology*, eds. B. K. Hall and W. M. Olson, 218-227. Cambridge, MA: Harvard University Press.
- Murray, J. D. 2003. *Mathematical biology II: Spatial models and biomedical applications*. Berlin: Springer.
- Nakamasu, A., G. Takahashi, A. Kanbe, and S. Kondo. 2009. Interactions between zebrafish pigment cells responsible for the generation of Turing patterns. *Proceedings of the National Academy of Sciences USA* 106:8429-8434.
- Newman, S. A., S. Christley, T. Glimm, H. G. E. Hentschel, B. Kazmierczak, Y.-T. Zhang, J. Zhu, and M. S. Alber. 2008. Multiscale models for vertebrate limb development. In *Multiscale modeling of developmental systems*, eds. S. Schnell, P. K. Maini, S. A. Newman, and T. J. Newman, 311-340. New York: Academic Press.
- Newman, S. A., and G. B. Müller. 2000. Epigenetic mechanisms of character origination. *Journal of Experimental Zoology (Molecular and Developmental Evolution)* 288:304-317.
- Newman, S. A., and G. B. Müller. 2005. Origination and innovation in the vertebrate limb skeleton: An epigenetic perspective. *Journal of Experimental Zoology Part B: Molecular and Developmental Evolution* 304B:593-609.
- Noble, D. 2002. Modeling the heart—from genes to cells to the whole organ. *Science* 295:1678-1682.
- Oates, A. C., L. G. Morelli, and S. Ares. 2012. Patterning embryos with oscillations: Structure, function and dynamics of the vertebrate segmentation clock. *Development* 139:625-639.
- O'Malley, M. A., I. Brigandt, A. C. Love, J. W. Crawford, J. A. Gilbert, R. Knight, S. D. Mitchell, and F. Rohwer. 2014. Multilevel research strategies and biological systems. *Philosophy of Science*. doi:10.1086/677889
- Paley, W. 1802. *Natural theology, or evidences of the existence and attributes of the deity, collected from the appearances of nature*. London: R. Faulder.
- Palmer, A. R. 2004. Symmetry breaking and the evolution of development. *Science* 306:828-833.
- Palmer, A. R. 2012. Developmental plasticity and the origin of novel forms: Unveiling of cryptic genetic variation via "use and disuse". *Journal of Experimental Zoology Part B: Molecular and Developmental Evolution* 318:466-479.

- Plikus, M. V., R. E. Baker, C.-C. Chen, C. Fare, D. de la Cruz, T. Andl, P. K. Maini, S. E. Millar, R. Widelitz, and C.-M. Chuong. 2011. Self-organizing and stochastic behaviors during the regeneration of hair stem cells. *Science* 332:586-589.
- Prud'homme, B., C. Minervino, M. Hocine, J. D. Cande, A. Aouane, H. D. Dufour, V. A. Kassner, and N. Gompel. 2011. Body plan innovation in treehoppers through the evolution of an extra wing-like appendage. *Nature* 473:83-86.
- Prum, R. O. 2005. Evolution of the morphological innovations of feathers. *Journal of Experimental Zoology Part B: Molecular and Developmental Evolution* 304B:570-579.
- Putnam, H. 1975. Philosophy and our mental life. In *Mind, language and reality (Philosophical papers, vol. 2)*, ed. H. Putnam, 291-303. Cambridge: Cambridge University Press.
- Rice, S. H. 2008. Theoretical approaches to the evolution of development and genetic architecture. *Annals of the New York Academy of Sciences* 1133:67-86.
- Rice, S. H. 2012. The place of development in mathematical evolutionary theory. *Journal of Experimental Zoology Part B: Molecular and Developmental Evolution* 318:480-488.
- Riedel-Kruse, I. H., C. Müller, and A. C. Oates. 2007. Synchrony dynamics during initiation, failure, and rescue of the segmentation clock. *Science* 317:1911-1915.
- Salazar-Ciudad, I., and J. Jernvall. 2002. A gene network model accounting for development and evolution of mammalian teeth. *Proceedings of the National Academy of Sciences USA* 99:8116-8120.
- Salazar-Ciudad, I., and J. Jernvall. 2010. A computational model of teeth and the developmental origins of morphological variation. *Nature* 464:583-586.
- Santillán, M., and M. C. Mackey. 2008. A proposed mechanism for the interaction of the segmentation clock and the determination front in somitogenesis. *PLoS ONE* 3:e1561.
- Schlosser, G., and G. P. Wagner. eds. 2004. *Modularity in development and evolution*. Chicago: University of Chicago Press.
- Schnell, S., P. K. Maini, S. A. Newman, and T. J. Newman. eds. 2008. *Multiscale modeling of developmental systems*. New York: Academic Press.
- Shigetani, Y., F. Sugahara, Y. Kawakami, Y. Murakami, S. Hirano, and S. Kuratani. 2002. Heterotopic shift of epithelial-mesenchymal interactions in vertebrate jaw evolution. *Science* 296:1316-1319.
- Siegal, M., D. Promislow, and A. Bergman. 2007. Functional and evolutionary inference in gene networks: Does topology matter? *Genetica* 129:83-103.
- Skipper, R. A., Jr., and R. L. Millstein. 2005. Thinking about evolutionary mechanisms: Natural selection. *Studies in History and Philosophy of Biological and Biomedical Sciences* 36:327-347.
- Smart, A. G., L. A. N. Amaral, and J. M. Ottino. 2008. Cascading failure and robustness in metabolic networks. *Proceedings of the National Academy of Sciences USA* 105:13223-13228.
- Strevens, M. 2008. *Depth: An account of scientific explanation*. Harvard: Harvard University Press.
- They, F. this volume. Explaining in contemporary molecular biology: beyond mechanisms. In *Explanation in biology: An enquiry into the diversity of explanatory patterns in the life sciences*, eds. P.-A. Braillard and C. Malaterre. Berlin: Springer.
- Turing, A. M. 1952. The chemical basis of morphogenesis. *Philosophical Transactions of the Royal Society of London. Series B: Biological Sciences* 237:37-72.
- Umulis, D., M. B. O'Connor, and H. G. Othmer. 2008. Robustness of embryonic spatial patterning in *Drosophila melanogaster*. In *Multiscale modeling of developmental systems*, eds. S. Schnell, P. K. Maini, S. A. Newman, and T. J. Newman, 65-111. New York: Academic Press.
- Uriu, K., Y. Morishita, and Y. Iwasa. 2010. Random cell movement promotes synchronization of the segmentation clock. *Proceedings of the National Academy of Sciences USA* 107:4979-4984.
- von Dassow, G., E. Meir, E. M. Munro, and G. M. Odell. 2000. The segment polarity network is a robust developmental module. *Nature* 406:188-192.

- von Dassow, G., and E. Munro. 1999. Modularity in animal development and evolution: Elements for a conceptual framework for EvoDevo. *Journal of Experimental Zoology (Molecular and Developmental Evolution)* 285:307-325.
- von Dassow, G., and G. M. Odell. 2002. Design and constraints of the *Drosophila* segment polarity module: Robust spatial patterning emerges from intertwined cell state switches. *Journal of Experimental Zoology (Molecular and Developmental Evolution)* 294:179-215.
- Wagner, A. 2005a. Distributed robustness versus redundancy as causes of mutational robustness. *BioEssays* 27:176-188.
- Wagner, A. 2005b. *Robustness and evolvability in living systems*. Princeton: Princeton University Press.
- Wagner, A. 2008. Gene duplications, robustness and evolutionary innovations. *BioEssays* 30:367-373.
- Wagner, G. P. 1996. Homologues, natural kinds and the evolution of modularity. *American Zoologist* 36:36-43.
- Wagner, G. P. 2000. What is the promise of developmental evolution? Part I: Why is developmental biology necessary to explain evolutionary innovations? *Journal of Experimental Zoology (Molecular and Developmental Evolution)* 288:95-98.
- Wagner, G. P. 2005. The developmental evolution of avian digit homology: An update. *Theory in Biosciences* 124:165-183.
- Wagner, G. P. 2007. How wide and how deep is the divide between population genetics and developmental evolution? *Biology and Philosophy* 22:145-153.
- Wagner, G. P., C.-H. Chiu, and M. D. Laubichler. 2000. Developmental evolution as a mechanistic science: The inference from developmental mechanisms to evolutionary processes. *American Zoologist* 40:819-831.
- Wagner, G. P., and B. Y. Misof. 1993. How can a character be developmentally constrained despite variation in developmental pathways? *Journal of Evolutionary Biology* 6:449-455.
- Wang, Y., X.-S. Zhang, and Y. Xia. 2009. Predicting eukaryotic transcriptional cooperativity by Bayesian network integration of genome-wide data. *Nucleic Acids Research* 37:5943-5958.
- Weber, M. 2005. *Philosophy of experimental biology*. Cambridge: Cambridge University Press.
- Weber, M. 2008. Causes without mechanisms: Experimental regularities, physical laws, and neuroscientific explanation. *Philosophy of Science* 75:995-1007.
- Weisberg, M. 2013. *Simulation and similarity: Using models to understand the world*. New York: Oxford University Press.
- West-Eberhard, M. J. 2003. *Developmental plasticity and evolution*. Oxford: Oxford University Press.
- West-Eberhard, M. J. 2005. Phenotypic accommodation: Adaptive innovation due to developmental plasticity. *Journal of Experimental Zoology Part B: Molecular and Developmental Evolution* 304B:610-618.
- Westerhoff, H. V., and D. B. Kell. 2007. The methodologies of systems biology. In *Systems biology: Philosophical foundations*, eds. F. C. Boogerd, F. J. Bruggeman, J.-H. S. Hofmeyr, and H. V. Westerhoff, 23-70. Amsterdam: Elsevier.
- Whitman, D. W., and A. A. Agrawal. 2009. What is phenotypic plasticity and why is it important? In *Phenotypic plasticity of insects: Mechanisms and consequences*, eds. D. W. Whitman and T. N. Ananthkrishnan, 1-63. Enfield: Science Publishers.
- Wing, S. S., S. H. Lecker, and R. T. Jago. 2011. Proteolysis in illness-associated skeletal muscle atrophy: From pathways to networks. *Critical Reviews in Clinical Laboratory Science* 48:49-70.
- Winther, R. G. 2006. Parts and theories in compositional biology. *Biology and Philosophy* 21:471-499.
- Winther, R. G. 2011. Part-whole science. *Synthese* 178:397-427.
- Woodward, J. 2002. What is a mechanism? A counterfactual account. *Philosophy of Science* 69:S366-S377.

- Woodward, J. 2003. *Making things happen: A theory of causal explanation*. Oxford: Oxford University Press.
- Young, R. L., and G. P. Wagner. 2011. Why ontogenetic homology criteria can be misleading: Lessons from digit identity transformations. *Journal of Experimental Zoology Part B: Molecular and Developmental Evolution* 316B:165-170.
- Zhu, J., Y.-T. Zhang, M. S. Alber, and S. A. Newman. 2010. Bare bones pattern formation: A core regulatory network in varying geometries reproduces major features of vertebrate limb development and evolution. *PLoS ONE* 5:e10892.

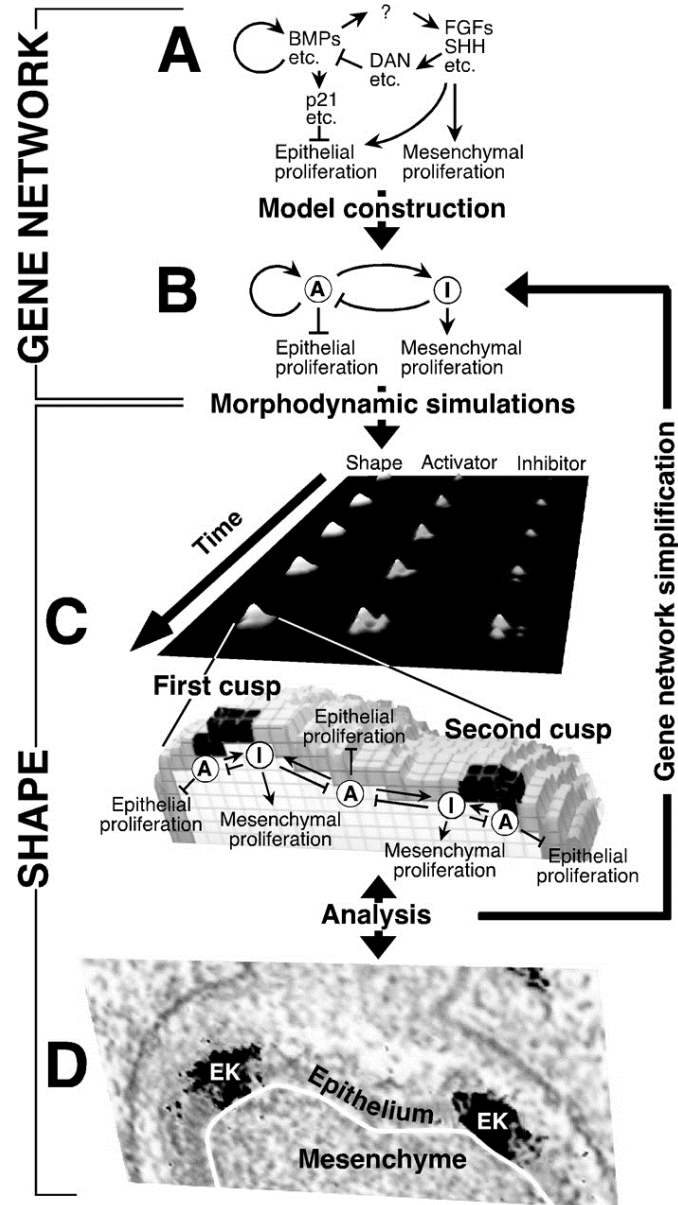

Fig. 1 Modeling of the development of mammalian teeth. An experimentally obtained causal network of molecular components (A) forms the basis of a simplified activator-inhibitor system (B). The mathematical model's prediction of the three-dimensional tooth shape and the distribution of the activator and inhibitor across developmental time (C) is compared to empirical information about mice teeth (D); EK = enamel knot (from Salazar-Ciudad and Jernvall 2002).

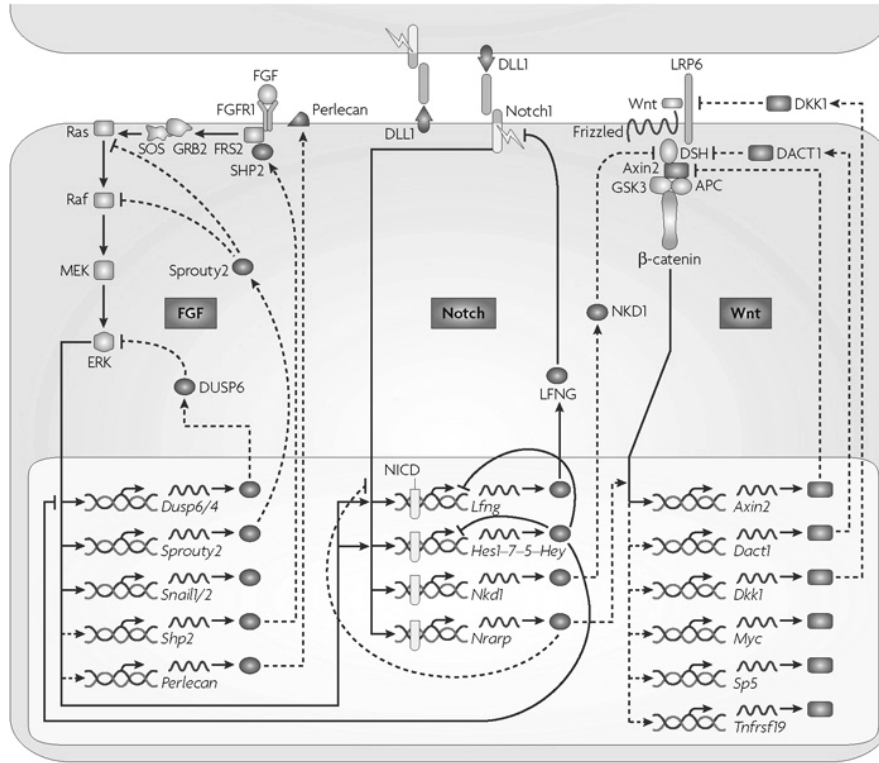

Fig. 2 The segmentation clock in mice. Apart from components involved in the signaling and synchronization with another cell (top), the figure shows the basic causal network of one cell's components underlying the generation of oscillations. Three major signaling pathways (FGF, Notch, and Wnt) are represented, where the area with light background highlights oscillatory genes, their mRNA transcripts, and their protein products (from Dequéant and Pourquié 2008; dashed lines are regulatory interactions that were inferred from other species or microarray data).